

**B.C. COAL LICENCES  
 TENURE STANDING**

 PROJECT: TELKWA NORTH

 YEAR: 1983

 DATE: MARCH 1984

GROUP NO.	LICENCE			ACQ/ADM		RENTALS		ANNIVERSARY DATE	WORK REQUIREMENT				TOTAL EXPLORATION			REMARKS
	NO.	LEGAL DESCRIPTION	AREA TOTAL/HA	YEAR	FEES	ANNUAL	TOTAL NEXT ANN.		EXPIRED	CURRENT	LIC. TERM	EXC. CREDIT	YEAR	AMOUNT	CASH IN LIEU	
327	15	LICENCES	3756		150	18,780	107,495	DECEMBER 31	283,962	165,125			78-79	165,225	-	THE LICENCES ARE
	4271	LOT 248	259	78							6th	\$197.11/HA.	79-80	-	-	IN GOOD STANDING
	4272	LOT 222	259	78							"	"	80-81	107,204	-	ON DEC. 31, 1983,
	4274	LOT 225	259	78							"	"	81-82	301,489	-	RENT PAID FOR
	4275	LOT 224	259	78							"	"	83	378,879	-	1984.
	4276	LOT 411	259	78							"	"				WORK COVERED:
	4277	LOT 410	259	78							"	"				78's LICENCES
	4278	LOT 228	259	78							"	"				FOR 84, 85, 86
	4279	LOT 229	259	78							"	"				PLUS \$47.11/HA.
	4280	LOT 238	259	78							"	"				79's LICENCES
	4281	LOT 244	259	78							"	"				FOR 84, 85, 86
	4283	1 Mile North of Lot 244	259	78							"	"				PLUS \$26.45/HA.
	5305	LOT 239	259	79							5th	\$151.45/HA.				80 LICENCE
	5306	LOT 243	259	79							"	"				FOR 84, 85, 86, 87
	5307	1 Mile North of Lot 243	259	79							"	"				PLUS \$13.95/HA.
	6040	North half of Lot 221	130	80							4th	\$163.95/HA.				





239

APPLICATION TO EXTEND TERM OF LICENCE

1. Leslie V. Gramantik ..... agent for Shell Canada Resources Limited....  
(Name) (Name)  
P.O. Box 100 ..... Calgary .....  
(Address) (Address)  
Alberta ..... T2P 2M7 .....  
Valid FMC No. 257677

hereby apply to the Minister to extend the term of Coal Licence(s) No(s) 4271, 4272, 4274 to 4281  
1243, 5305 to 5307, 6040, Fifteen licences, 3756 hectares.  
for a further period of one year.

2 Property name Telkwa HqLn, Group No. 327, Range 5, Coast L.D.

3 I am allowing the following Coal Licence(s) No(s) to forfeit NA

4 I have performed, or caused to be performed, during the period April 1, 1983 to  
March 31, 1984 work to the value of at least \$ 378,879

on the location of coal licence(s) as follows:

CATEGORY OF WORK	Licence(s) No(s)	Apportioned Cost
Geological mapping		
Surveys: Geophysical		
Geochemical		
Other Location	4271	10,447
Road construction		
Surface work		
Underground work		
Drilling	4271	185,399
Logging, sampling, and testing	4271	109,697
Reclamation	4271	2,100
Other work (specify)	4271	19,263
Off property costs		51,973

5 I wish to apply \$ 378,879 of this value of work on Coal Licence(s) No(s) 4271, 4272, 4274 to 4281, 4283, 5305-5307, 6040

6 I wish to pay cash in lieu of work in the amount of \$ NA on Coal Licence(s) No(s)

7 The work performed on the location(s) is detailed in the attached report entitled Telkwa Project  
Geological Assessment Report, 1983

March 20th, 1984  
(Date)

*Gramantik*  
(Signature)  
Assistant Landman  
(Position)

**GEOLOGICAL MAPPING**

Yes  No

Area (Hectares)

Scale

Duration

Reconnaissance .....  
 Detail - Surface .....  
           Underground .....  
 Other\* (specify) .....

Total Cost \$ .....

**GEOPHYSICAL/GEOCHEMICAL SURVEYS**

Yes  No

Method .....  
 Grid .....  
 Topographic .....  
 Other\* (specify) .....

Total Cost \$ 10,447

**ROAD CONSTRUCTION**

Yes  No

Length ..... Width .....  
 On Licence(s) No.(s) .....  
 Access to .....

Total Cost \$ .....

**SURFACE WORK**

Yes  No

	Length	Width	Depth	Cost
Trenching	.....	.....	.....	.....
Seam Tracing	.....	.....	.....	.....
Crosscutting	.....	.....	.....	.....
Other* (specify)	.....	.....	.....	.....

Total Cost \$ .....

**UNDERGROUND WORK**

Yes  No

	No. of Adits	Maximum Length	No. of Holes	Total Metres	Cost
Test Adits	.....	.....	.....	.....	.....
Other workings*	.....	.....	.....	.....	.....

Total Cost \$ .....

**DRILLING**

Yes  No

	Hole Size	No. of Holes	Total Metres	Cost
Core: Diamond	.....	.....	.....	.....
Wireline	NQ	22	3054.8	185,399
Rotary: Conventional	.....	.....	.....	.....
Reverse circulation	.....	.....	.....	.....
Other* (specify)	L.T. Thomas Diamond Drilling Co. Ltd.			
Contractor	Bulkley Valley Mine Site			
Where is the core stored?	.....			

Total Cost \$ 185,399

**LOGGING, SAMPLING, AND TESTING**

Yes  No

Lithology: Drill samples	<input checked="" type="checkbox"/>	Core samples	<input checked="" type="checkbox"/>	Bulk samples	<input checked="" type="checkbox"/>
Logs: Gamma-neutron	<input checked="" type="checkbox"/>	Density	<input checked="" type="checkbox"/>		
Other* (specify)	.....				
Testing: Proximate analysis	<input checked="" type="checkbox"/>	FSI	<input checked="" type="checkbox"/>	Washability	<input checked="" type="checkbox"/>
Carbonization	<input type="checkbox"/>	Petrographic	<input checked="" type="checkbox"/>	Plasticity	<input type="checkbox"/>
Other* (specify)	.....				

Total Cost \$ 109,697

**RECLAMATION**

Yes  No

Details ..... Total Cost \$ 2,100

**OTHER WORK (Specify details)**

Yes  No

Access/Crow Damage Payments .....  
 Total Cost \$ 19,263

**OFF-PROPERTY COSTS**

Yes  No

Details Report, Drafting, Reproduction ..... Total Cost \$ 51,973

Total Expenditures \$ 378,879

24-03-20  
 (Date)

*W.F. Kennel*  
 (Signature)

Manager - Accounting, CNRL  
 (Position)

\* All items, including other work, to be included



Province of British Columbia  
Ministry of Energy, Mines and Petroleum Resources

**APPLICATION TO EXTEND TERM OF LICENCE**

I, Lloyd Gething agent for Bulkley Valley Coal Limited  
(Name) (Name)  
R.R. #1 Telkwa  
(Address) (Address)  
British Columbia VOV 2X0  
(Address) (Address)  
 Valid FMC No. 179747

hereby apply to the Minister to extend the term of Coal Licence(s) No(s). 3709, 3710, 3875 to 3885.  
Thirteen licences, 3367 hectares  
 for a further period of one year.

- 2 Property name Telkwa, Group No. 221, Range 5 Coast L.D.
- 3 I am allowing the following Coal Licence(s) No(s). to forfeit NA
- 4 I have performed, or caused to be performed, during the period April 1, 1984 to March 31, 1984, work to the value of at least \$ 475,233 on the location of coal licence(s) as follows:

CATEGORY OF WORK	Licence(s) No(s).	Apportioned Cost
Geological mapping		
Surveys: Geophysical	<u>3710</u>	<u>13,052</u>
Geochemical		
Other Location	<u>3709, 3710, 3876, 3877</u>	<u>7,599</u>
Road construction	<u>3709, 3710, 3876, 3877</u>	<u>97,475</u>
Surface work		
Underground work		
Drilling	<u>3709, 3876, 3877</u>	<u>207,222</u>
Logging, sampling, and testing	<u>3709, 3876, 3877</u>	<u>93,436</u>
Reclamation	<u>3709, 3876, 3877</u>	<u>4,477</u>
Other work (specify)		
Off property costs		<u>51,972</u>

- 5 I wish to apply \$ 475,233 of this value of work on Coal Licence(s) No(s). 3709, 3710, 3875 to 3885.
- 6 I wish to pay cash in lieu of work in the amount of \$ NA on Coal Licence(s) No(s).
- 7 The work performed on the location(s) is detailed in the attached report entitled Telkwa Project Geophysical Assessment Report, 1983.

March 20th, 1984  
(Date)

ORIGINAL SIGN BY L. GETHING  
(Signature)

PRESIDENT  
(Position)



Report on the Sealing of Drillholes

Inspection District #9 Date of Report SEPTEMBER 20 1983

Company CROWS NEST RESOURCES LTD Land District COAST #5

Coal Map Number 101 Licence Number CL 3876

1. Number of Drillhole 251-6 Bags of Cement 130

2. Surface elevation 871.9

3. Type (Vertical, diamond, rotary, size etc.) VERTICAL DIAMOND 20 CM

4. Drilled by: Name of Contractor: J.T. THOMAS DIAMOND DRILLING LTD  
Name of Exploration Company CROWS NEST RESOURCES LTD

5. Date of Completion: SEPTEMBER 10, 1983

6. Date of Sealing: SEPTEMBER 20, 1983

7. Sealed by: Name of Contractor: BULKLEY CONCRETE LTD  
Name of Exploration Company CROWS NEST RESOURCES LTD

8. (a) Has any casing, drill pipe, drill bits, core barrel, etc. been left in the hole

(b) If so, give details and location: SURFACE CASING LEFT IN THE HOLE

9. (a) Was the drillhole sealed in the manner outlined in the Chief Inspectors Instructions? YES

(b) If no, give reasons and details of variation:

10. (a) Was the sealing effective? YES

(b) Details of any tests carried out:

11. I certify that the above drillhole has been effectively sealed in accordance with the instructions of the Chief Inspector of Mines.

Signature: Robert Pasillo

Designation: FIELD COORDINATOR

Date: 09-23-83

Countersignature: [Signature]

Designation: OPERATOR

Date: SEPTEMBER 20 1983

239

Report on the Sealing of Drillholes

Inspection District #9 Date of Report SEPTEMBER 20/83  
Company CROWS NEST RESOURCES LTD Land District COAST #5  
Coal Map Number 101 Licence Number L 401

1. Number of Drillhole 353-6 Bags of Cement 80

2. Surface elevation 720.3

3. Type (Vertical, diamond, rotary, size etc.) VERTICAL DIAMOND 20 CM

4. Drilled by: Name of Contractor: J.T. THOMAS DIAMOND DRILLING LTD  
Name of Exploration Company CROWS NEST RESOURCES LTD

5. Date of Completion: SEPTEMBER 3 1983

6. Date of Sealing: SEPTEMBER 20 1983

7. Sealed by: Name of Contractor: BULKLEY CONCRETE LTD  
Name of Exploration Company CROWS NEST RESOURCES LTD

8. (a) Has any casing, drill pipe, drill bits, core barrel, etc. been left in the ho

(b) If so, give details and location: SURFACE CASING LEFT IN  
THE HOLE

9. (a) Was the drillhole sealed in the manner outlined in the Chief Inspectors  
Instructions? YES

(b) If no, give reasons and details of variation: \_\_\_\_\_  
\_\_\_\_\_  
\_\_\_\_\_

10. (a) Was the sealing effective? YES

(b) Details of any tests carried out: \_\_\_\_\_  
\_\_\_\_\_

11. I certify that the above drillhole has been effectively sealed in accordance with  
the instructions of the Chief Inspector of Mines.

Signature: [Signature]

Designation: FIELD COORDINATOR

Date: 09-23-83

Countersignature: [Signature]

Designation: OPERATOR

Date: SEPTEMBER 20 1983

**239**



Report on the Sealing of Drillholes

Inspection District # 9 Date of Report SEPTEMBER 21/83

Company CROWS NEST RESOURCES LTD Land District COAST #5

Coal Map Number 101 Licence Number L 391

1. Number of Drillhole 313-6 Bags of Cement 90

2. Surface elevation 750.6

3. Type (Vertical, diamond, rotary, size etc. VERTICAL DIAMOND 20 CM

4. Drilled by: Name of Contractor: J.T. THOMAS DIAMOND DRILLING LTD  
Name of Exploration Company CROWS NEST RESOURCES LTD

5. Date of Completion: SEPTEMBER 13, 1983

6. Date of Sealing: SEPT 21/83

7. Sealed by: Name of Contractor: BULKLEY CONCRETE LTD  
Name of Exploration Company CROWS NEST RESOURCES LTD

8. (a) Has any casing, drill pipe, drill bits, core barrel, etc. been left in the ho

(b) If so, give details and location: SURFACE CASING LEFT IN THE HOLE

9. (a) Was the drillhole sealed in the manner outlined in the Chief Inspectors Instructions? YES

(b) If no, give reasons and details of variation: \_\_\_\_\_

10. (a) Was the sealing effective? YES

(b) Details of any tests carried out: \_\_\_\_\_

11. I certify that the above drillhole has been effectively sealed in accordance with the instructions of the Chief Inspector of Mines.

Signature: Robert Ault

Designation: FIELD COORDINATOR

Date: 09-23-83

Countersignature: [Signature]

Designation: OPERATOR

Date: SEPTEMBER 20, 1983

239

Report on the Sealing of Drillholes

Inspection District # 9 Date of Report SEPTEMBER 21/83

Company CROWS NEST RESOURCES LTD Land District COAST #5

Coal Map Number 101 Licence Number L 391

1. Number of Drillhole 307-6 Bags of Cement 50

2. Surface elevation 763.4

3. Type (Vertical, diamond, rotary, size etc.) VERTICAL DIAMOND 20 CM

4. Drilled by: Name of Contractor: J.T. THOMAS DIAMOND DRILLING LTD  
Name of Exploration Company CROWS NEST RESOURCES LTD

5. Date of Completion: SEPTEMBER 20, 1983

6. Date of Sealing: SEPT 21 /83

7. Sealed by: Name of Contractor: BULKLEY CONCRETE LTD  
Name of Exploration Company CROWS NEST RESOURCES LTD

8. (a) Has any casing, drill pipe, drill bits, core barrel, etc. been left in the hole

(b) If so, give details and location: SURFACE CASING LEFT IN  
THE HOLE

9. (a) Was the drillhole sealed in the manner outlined in the Chief Inspectors Instructions? Yes

(b) If no, give reasons and details of variation: \_\_\_\_\_

10. (a) Was the sealing effective? Yes

(b) Details of any tests carried out: \_\_\_\_\_

11. I certify that the above drillhole has been effectively sealed in accordance with the instructions of the Chief Inspector of Mines.

Signature: Robert A. Della

Designation: FIELD COORDINATOR

Date: 09-23-83

Countersignature: [Signature]

Designation: OPERATOR

Date: SEPTEMBER 21, 1983

239

Report on the Sealing of Drillholes

1K-TELKWA 83(3)A

Inspection District 49 Date of Report December 15/83  
Company CROWS NEST RESOURCES LTD Land District COAST #5  
Coal Map Number 101 Licence Number 4271

1. Number of Drillhole 363 Bags of Cement 20

2. Surface elevation 704.0

3. Type (Vertical, diamond, rotary, size etc.) VERTICAL DIAMOND N.G.

4. Drilled by: Name of Contractor: J.T. THOMAS DIAMOND DRILLING LTD  
Name of Exploration Company CROWS NEST RESOURCES LTD

5. Date of Completion: Dec 14 1983

6. Date of Sealing: Dec 14 1983

7. Sealed by: Name of Contractor: J.T. THOMAS DIAMOND DRILLING LTD  
Name of Exploration Company CROWS NEST RESOURCES LTD

8. (a) Has any casing, drill pipe, drill bits, core barrel, etc. been left in the hole?  
No  
(b) If so, give details and location: \_\_\_\_\_

9. (a) Was the drillhole sealed in the manner outlined in the Chief Inspectors Instructions? Yes

(b) If no, give reasons and details of variation: \_\_\_\_\_

10. (a) Was the sealing effective? Yes

(b) Details of any tests carried out: \_\_\_\_\_

11. I certify that the above drillhole has been effectively sealed in accordance with the instructions of the Chief Inspector of Mines.

Signature: Robert Field

Designation: FIELD COORDINATOR

Date: Dec 15 1983

Countersignature: Lin Rine

Designation: OPERATIONS MANAGER

Date: Dec 15 1983

239

Report on the Sealing of Drillholes

14-TELKWA 83(3)A

Inspection District A9 Date of Report December 19 1983  
Company CROWS NEST RESOURCES LTD Land District COAST #5  
Coal Map Number 101 Licence Number 4271

1. Number of Drillhole 369 Bags of Cement 18  
2. Surface elevation 675.2  
3. Type (Vertical, diamond, rotary, size etc.) VERTICAL DIAMOND NA  
4. Drilled by: Name of Contractor: J.T. THOMAS DIAMOND DRILLING LTD  
Name of Exploration Company CROWS NEST RESOURCES LTD

5. Date of Completion: December 18, 1983  
6. Date of Sealing: December 18, 1983

7. Sealed by: Name of Contractor: J.T. THOMAS DIAMOND DRILLING LTD  
Name of Exploration Company CROWS NEST RESOURCES LTD

8. (a) Has any casing, drill pipe, drill bits, core barrel, etc. been left in the hole?  
No  
(b) If so, give details and location: \_\_\_\_\_

9. (a) Was the drillhole sealed in the manner outlined in the Chief Inspectors  
Instructions? yes  
(b) If no, give reasons and details of variation: \_\_\_\_\_

10. (a) Was the sealing effective? yes  
(b) Details of any tests carried out: \_\_\_\_\_

11. I certify that the above drillhole has been effectively sealed in accordance with  
the instructions of the Chief Inspector of Mines.

Signature: [Signature]

Designation: FIELD COORDINATOR

Date: December 19 1983

Countersignature: [Signature]

Designation: OPERATIONS MANAGER

Date: December 19 1983

**239**

Report on the Sealing of Drillholes

Inspection District # 9 Date of Report C JUNE 10/83  
 Company CROWS NEST RESOURCES LTD Land District COAST #5  
 Coal Map Number 101 Licence Number L391

1. Number of Drillhole 301 Bags of Cement 6

2. Surface elevation 756.9

3. Type (Vertical, diamond, rotary, size etc.) Vertical NQ Diamond

4. Drilled by: Name of Contractor: J. T. THOMAS DIAMOND DRILLING LTD  
 Name of Exploration Company CROWS NEST RESOURCES LTD

5. Date of Completion: JUNE 1 1983

6. Date of Sealing: JUNE 10 1983

7. Sealed by: Name of Contractor: J. T. THOMAS DIAMOND DRILLING LTD  
 Name of Exploration Company CROWS NEST RESOURCES LTD

8. (a) Has any casing, drill pipe, drill bits, core barrel, etc. been left in the hole

(b) If so, give details and location: A short piece of pipe was jammed in hole 6.2 m from surface.

9. (a) Was the drillhole sealed in the manner outlined in the Chief Inspectors Instructions? No.

(b) If no, give reasons and details of variation: The metal pipe prevented placing the rods on bottom, so the hole was cemented from above the pipe until cement returned to the collar.

10. (a) Was the sealing effective? \_\_\_\_\_

(b) Details of any tests carried out: \_\_\_\_\_

11. I certify that the above drillhole has been effectively sealed in accordance with the instructions of the Chief Inspector of Mines.

Signature: Robert P. Helle

Designation: Field Coordinator

Date: 06-10-83

Countersignature: Len Bell

Designation: Operations Manager

Date: 06-10-83

**239**

Report on the Sealing of Drillholes

TK-TEKWA 83L30

Inspection District #9 Date of Report JUNE 3/83

Company CROWS NEST RESOURCES LTD Land District COAST #5

Coal Map Number 101 Licence Number L 391

1. Number of Drillhole 302 Bags of Cement 8

2. Surface elevation 753.4

3. Type (Vertical, diamond, rotary, size etc.) VERTICAL DIAMOND NQ

4. Drilled by: Name of Contractor: J. T. THOMAS DIAMOND DRILLING LTD

Name of Exploration Company CROWS NEST RESOURCES LTD

5. Date of Completion: JUNE 2 1983

6. Date of Sealing: JUNE 2 1983

7. Sealed by: Name of Contractor: J. T. THOMAS DIAMOND DRILLING LTD

Name of Exploration Company CROWS NEST RESOURCES LTD

8. (a) Has any casing, drill pipe, drill bits, core barrel, etc. been left in the hole?

(b) If so, give details and location: HOLE FREE OF ANY

OBSTRUCTIONS

9. (a) Was the drillhole sealed in the manner outlined in the Chief Inspectors Instructions? YES

(b) If no, give reasons and details of variation:

10. (a) Was the sealing effective? YES

(b) Details of any tests carried out:

11. I certify that the above drillhole has been effectively sealed in accordance with the instructions of the Chief Inspector of Mines.

Signature: Robert Pritto

Designation: FIELD COORDINATOR

Date: JUNE 3 1983

Countersignature: Ann Baker

Designation: Operations Manager

Date: 06-03-83

239

Report on the Sealing of Drillholes

Inspection District #9 Date of Report JUNE 4 1983

Company CROWS NEST RESOURCES LTD Land District COAST #5

Coal Map Number 101 Licence Number L 391

1. Number of Drillhole 303 Bags of Cement 8

2. Surface elevation 749.8

3. Type (Vertical, diamond, rotary, size etc. Vertical diamond NA

4. Drilled by: Name of Contractor: J. T. THOMAS DIAMOND DRILLING LTD

Name of Exploration Company CROWS NEST RESOURCES LTD

5. Date of Completion: JUNE 3 1983

6. Date of Sealing: JUNE 3 1983

7. Sealed by: Name of Contractor: J. T. THOMAS DIAMOND DRILLING LTD

Name of Exploration Company CROWS NEST RESOURCES LTD

8. (a) Has any casing, drill pipe, drill bits, core barrel, etc. been left in the hole?

(b) If so, give details and location: NO

9. (a) Was the drillhole sealed in the manner outlined in the Chief Inspectors Instructions? YES

(b) If no, give reasons and details of variation:

10. (a) Was the sealing effective? YES

(b) Details of any tests carried out:

11. I certify that the above drillhole has been effectively sealed in accordance with the instructions of the Chief Inspector of Mines.

Signature: Robert Hutto

Designation: Field Coordinator

Date: 06-04-83

Countersignature: Jim Baker

Designation: Operations Manager

Date: 06-04-83

239

Report on the Sealing of Drillholes

Inspection District #9 Date of Report JUNE 15 1983

Company CROWS NEST RESOURCES LTD Land District COAST #5

Coal Map Number 101 Licence Number L 391

1. Number of Drillhole 304 Bags of Cement 8

2. Surface elevation 749.4

3. Type (Vertical, diamond, rotary, size etc.) Vertical diamond NA

4. Drilled by: Name of Contractor: J. T. THOMAS DIAMOND DRILLING LTD  
Name of Exploration Company CROWS NEST RESOURCES LTD

5. Date of Completion: JUNE 4 1983

6. Date of Sealing: JUNE 15 1983

7. Sealed by: Name of Contractor: J. T. THOMAS DIAMOND DRILLING LTD  
Name of Exploration Company CROWS NEST RESOURCES LTD

8. (a) Has any casing, drill pipe, drill bits, core barrel, etc. been left in the hole?

(b) If so, give details and location: A SONIC GEOPHYSICAL logging tool is located 15.2 m down the hole, and cable from 15.2 m to surface

9. (a) Was the drillhole sealed in the manner outlined in the Chief Inspectors Instructions? No

(b) If no, give reasons and details of variation: The cement was poured down from surface due to the obstruction.

10. (a) Was the sealing effective? Yes

(b) Details of any tests carried out:

11. I certify that the above drillhole has been effectively sealed in accordance with the instructions of the Chief Inspector of Mines.

Signature: Robert Pretto

Designation: Field Coordinator

Date: 06-15-84

Countersignature: Lynn Baker

Designation: Operations Manager

Date: 06-15-84

257



Report on the Sealing of Drillholes

Inspection District #9 Date of Report JUNE 6 / 83  
Company CROWS NEST RESOURCES LTD Land District COAST #5  
Coal Map Number 101 Licence Number L 391

1. Number of Drillhole 305 Bags of Cement 10  
2. Surface elevation 744.0  
3. Type (Vertical, diamond, rotary, size etc.) VERTICAL DIAMOND NO  
4. Drilled by: Name of Contractor: J. T. THOMAS DIAMOND DRILLING LTD  
Name of Exploration Company CROWS NEST RESOURCES LTD

5. Date of Completion: JUNE 5 / 83

6. Date of Sealing: JUNE 5 / 83

7. Sealed by: Name of Contractor: J. T. THOMAS DIAMOND DRILLING LTD  
Name of Exploration Company CROWS NEST RESOURCES LTD

8. (a) Has any casing, drill pipe, drill bits, core barrel, etc. been left in the hole?  
(b) If so, give details and location: No obstructions in hole

9. (a) Was the drillhole sealed in the manner outlined in the Chief Inspectors Instructions? YES  
(b) If no, give reasons and details of variation:

10. (a) Was the sealing effective? YES  
(b) Details of any tests carried out:

11. I certify that the above drillhole has been effectively sealed in accordance with the instructions of the Chief Inspector of Mines.

Signature: Robert Huello  
Designation: Field Coordinator  
Date: 06-06-83  
Countersignature: Jim Fisher  
Designation: Operations Manager  
Date: 06-06-83

239

Report on the Sealing of Drillholes

Inspection District #9 Date of Report JUNE 7 / 83

Company CROWS NEST RESOURCES LTD Land District COAST #5

Coal Map Number 101 Licence Number L 391

1. Number of Drillhole 306 Bags of Cement 12

2. Surface elevation 760.1

3. Type (Vertical, diamond, rotary, size etc.) Vertical diamond NA

4. Drilled by: Name of Contractor: J. T. THOMAS DIAMOND DRILLING LTD

Name of Exploration Company CROWS NEST RESOURCES LTD

5. Date of Completion: June 6 / 83

6. Date of Sealing: June 6 / 83

7. Sealed by: Name of Contractor: J. T. THOMAS DIAMOND DRILLING LTD

Name of Exploration Company CROWS NEST RESOURCES LTD

8. (a) Has any casing, drill pipe, drill bits, core barrel, etc. been left in the hole

(b) If so, give details and location: No materials left in hole

9. (a) Was the drillhole sealed in the manner outlined in the Chief Inspectors Instructions? Yes

(b) If no, give reasons and details of variation:

10. (a) Was the sealing effective? Yes

(b) Details of any tests carried out:

11. I certify that the above drillhole has been effectively sealed in accordance with the instructions of the Chief Inspector of Mines.

Signature: Robert Hallett

Designation: Field Coordinator

Date: 06-07-83

Countersignature: Len Bell

Designation: Operations Manager

Date: 06-07-83

239

Report on the Sealing of Drillholes

Inspection District #9 Date of Report JUNE 8/83  
Company CROWS NEST RESOURCES LTD Land District COAST #5  
Coal Map Number 101 Licence Number L 391

1. Number of Drillhole 307 Bags of Cement 12  
2. Surface elevation 763.4  
3. Type (Vertical, diamond, rotary, size etc.) VERTICAL DIAMOND NR  
4. Drilled by: Name of Contractor: J. T. THOMAS DIAMOND DRILLING LTD  
Name of Exploration Company CROWS NEST RESOURCES LTD

5. Date of Completion: 06-07-83  
6. Date of Sealing: 06-07-83  
7. Sealed by: Name of Contractor: J. T. THOMAS DIAMOND DRILLING LTD  
Name of Exploration Company CROWS NEST RESOURCES LTD

8. (a) Has any casing, drill pipe, drill bits, core barrel, etc. been left in the hole?  
(b) If so, give details and location:

9. (a) Was the drillhole sealed in the manner outlined in the Chief Inspectors Instructions? Yes  
(b) If no, give reasons and details of variation:

10. (a) Was the sealing effective? Yes  
(b) Details of any tests carried out:

11. I certify that the above drillhole has been effectively sealed in accordance with the instructions of the Chief Inspector of Mines.

Signature: Robert Puetto  
Designation: FIELD COORDINATOR  
Date: 06-08-83  
Countersignature: Ian Bala  
Designation: OPERATIONS MANAGER  
Date: 06-08-83

239

Report on the Sealing of Drillholes

Inspection District #9 Date of Report JUNE 10/83

Company CROWS NEST RESOURCES LTD Land District COAST #5

Coal Map Number 101 Licence Number L391

1. Number of Drillhole 308 Bags of Cement 12

2. Surface elevation 762.0

3. Type (Vertical, diamond, rotary, size etc. Vertical diamond ND

4. Drilled by: Name of Contractor: J. T. THOMAS DIAMOND DRILLING LTD

Name of Exploration Company CROWS NEST RESOURCES LTD

5. Date of Completion: 06-09-83

6. Date of Sealing: 06-09-83

7. Sealed by: Name of Contractor: J. T. THOMAS DIAMOND DRILLING LTD

Name of Exploration Company CROWS NEST RESOURCES LTD

8. (a) Has any casing, drill pipe, drill bits, core barrel, etc. been left in the hole

(b) If so, give details and location:

9. (a) Was the drillhole sealed in the manner outlined in the Chief Inspectors Instructions? Yes

(b) If no, give reasons and details of variation:

10. (a) Was the sealing effective? Yes

(b) Details of any tests carried out:

11. I certify that the above drillhole has been effectively sealed in accordance with the instructions of the Chief Inspector of Mines.

Signature: Robert Hatto

Designation: Field Coordinator

Date: 06-10-83

Countersignature: Len Bell

Designation: Operations Manager

Date: 06-10-83

239

Report on the Sealing of Drillholes

Inspection District #9 Date of Report JUNE 10/83  
Company CROWS NEST RESOURCES LTD Land District COAST #5  
Coal Map Number 101 Licence Number 1391

- 1. Number of Drillhole 309 Bags of Cement 8
- 2. Surface elevation 759.9
- 3. Type (Vertical, diamond, rotary, size etc.) Vertical Diamond NO
- 4. Drilled by: Name of Contractor: J. T. THOMAS DIAMOND DRILLING LTD  
Name of Exploration Company CROWS NEST RESOURCES LTD

- 5. Date of Completion: 06-09-83
- 6. Date of Sealing: 06-09-83

- 7. Sealed by: Name of Contractor: J. T. THOMAS DIAMOND DRILLING LTD  
Name of Exploration Company CROWS NEST RESOURCES LTD

- 8. (a) Has any casing, drill pipe, drill bits, core barrel, etc. been left in the hole
- (b) If so, give details and location: No materials left down hole

- 9. (a) Was the drillhole sealed in the manner outlined in the Chief Inspectors Instructions? Yes
- (b) If no, give reasons and details of variation:

- 10. (a) Was the sealing effective? Yes
- (b) Details of any tests carried out:

11. I certify that the above drillhole has been effectively sealed in accordance with the instructions of the Chief Inspector of Mines.

Signature: Robert Muelto

Designation: Field Coordinator

Date: 06-10-83

Countersignature: [Signature]

Designation: Operations Manager

Date: 06-13-83

239

Report on the Sealing of Drillholes

Inspection District #9 Date of Report JUNE 11/83

Company CROWS NEST RESOURCES LTD Land District COAST #5

Coal Map Number 101 Licence Number L 391

1. Number of Drillhole 310 Bags of Cement 12

2. Surface elevation 762.1

3. Type (Vertical, diamond, rotary, size etc.) Vertical Diamond NQ

4. Drilled by: Name of Contractor: J. T. THOMAS DIAMOND DRILLING LTD

Name of Exploration Company CROWS NEST RESOURCES LTD

5. Date of Completion: 06-10-83

6. Date of Sealing: 06-10-83

7. Sealed by: Name of Contractor: J. T. THOMAS DIAMOND DRILLING LTD

Name of Exploration Company CROWS NEST RESOURCES LTD

8. (a) Has any casing, drill pipe, drill bits, core barrel, etc. been left in the hole

(b) If so, give details and location: CLEAN HOLE

9. (a) Was the drillhole sealed in the manner outlined in the Chief Inspectors Instructions? Yes

(b) If no, give reasons and details of variation:

10. (a) Was the sealing effective? Yes

(b) Details of any tests carried out:

11. I certify that the above drillhole has been effectively sealed in accordance with the instructions of the Chief Inspector of Mines.

Signature: Robert Hallett

Designation: Field Coordinator

Date: 06-11-83

Countersignature: Alan Fisher

Designation: Operations Manager

Date: 06-13-83

239

Report on the Sealing of Drillholes

Inspection District #9 Date of Report JUNE 11/83  
Company CROWS NEST RESOURCES LTD Land District COAST #5  
Coal Map Number 101 Licence Number L 391

1. Number of Drillhole 311 Bags of Cement 5  
2. Surface elevation 760.7  
3. Type (Vertical, diamond, rotary, size etc.) Vertical Diamond NA  
4. Drilled by: Name of Contractor: J. T. THOMAS DIAMOND DRILLING LTD  
Name of Exploration Company CROWS NEST RESOURCES LTD

5. Date of Completion: 06-10-83

6. Date of Sealing: 06-10-83

7. Sealed by: Name of Contractor: J. T. THOMAS DIAMOND DRILLING LTD  
Name of Exploration Company CROWS NEST RESOURCES LTD

8. (a) Has any casing, drill pipe, drill bits, core barrel, etc. been left in the hole?  
(b) If so, give details and location:

9. (a) Was the drillhole sealed in the manner outlined in the Chief Inspectors Instructions? YES

(b) If no, give reasons and details of variation:

10. (a) Was the sealing effective? YES

(b) Details of any tests carried out:

11. I certify that the above drillhole has been effectively sealed in accordance with the instructions of the Chief Inspector of Mines.

Signature: Robert Hetherington

Designation: FIELD COORDINATOR

Date: 06-11-83

Countersignature: Ian Baker

Designation: Operations Manager

Date: 06-13-83

239

Report on the Sealing of Drillholes

Inspection District #9 Date of Report JUNE 12/83  
 Company CROWS NEST RESOURCES LTD Land District COAST #9  
 Coal Map Number 101 Licence Number L 391

1. Number of Drillhole 312 Bags of Cement \_\_\_\_\_  
 2. Surface elevation 764.9  
 3. Type (Vertical, diamond, rotary, size etc.) VERTICAL DIAMOND NG  
 4. Drilled by: Name of Contractor: J. T. THOMAS DIAMOND DRILLING LTD  
 Name of Exploration Company CROWS NEST RESOURCES LTD

5. Date of Completion: 06-12-83

6. Date of Sealing: \_\_\_\_\_

7. Sealed by: Name of Contractor: J. T. THOMAS DIAMOND DRILLING LTD  
 Name of Exploration Company CROWS NEST RESOURCES LTD

8. (a) Has any casing, drill pipe, drill bits, core barrel, etc. been left in the hole?  
 (b) If so, give details and location: piezometer installed in  
this hole see attached diagram

9. (a) Was the drillhole sealed in the manner outlined in the Chief Inspectors  
 Instructions? No  
 (b) If no, give reasons and details of variation: The drill hole  
is being used to obtain ground water data

10. (a) Was the sealing effective? \_\_\_\_\_  
 (b) Details of any tests carried out: \_\_\_\_\_

11. I certify that the above drillhole has been effectively sealed in accordance with  
 the instructions of the Chief Inspector of Mines.

Signature: [Signature]  
 Designation: Field Coordinator  
 Date: 06-12-83  
 Countersignature: [Signature]  
 Designation: Operations Manager  
 Date: 06-13-83

**239**



# STAND PIPE PIEZOMETER INSTALLATION @ DH 312

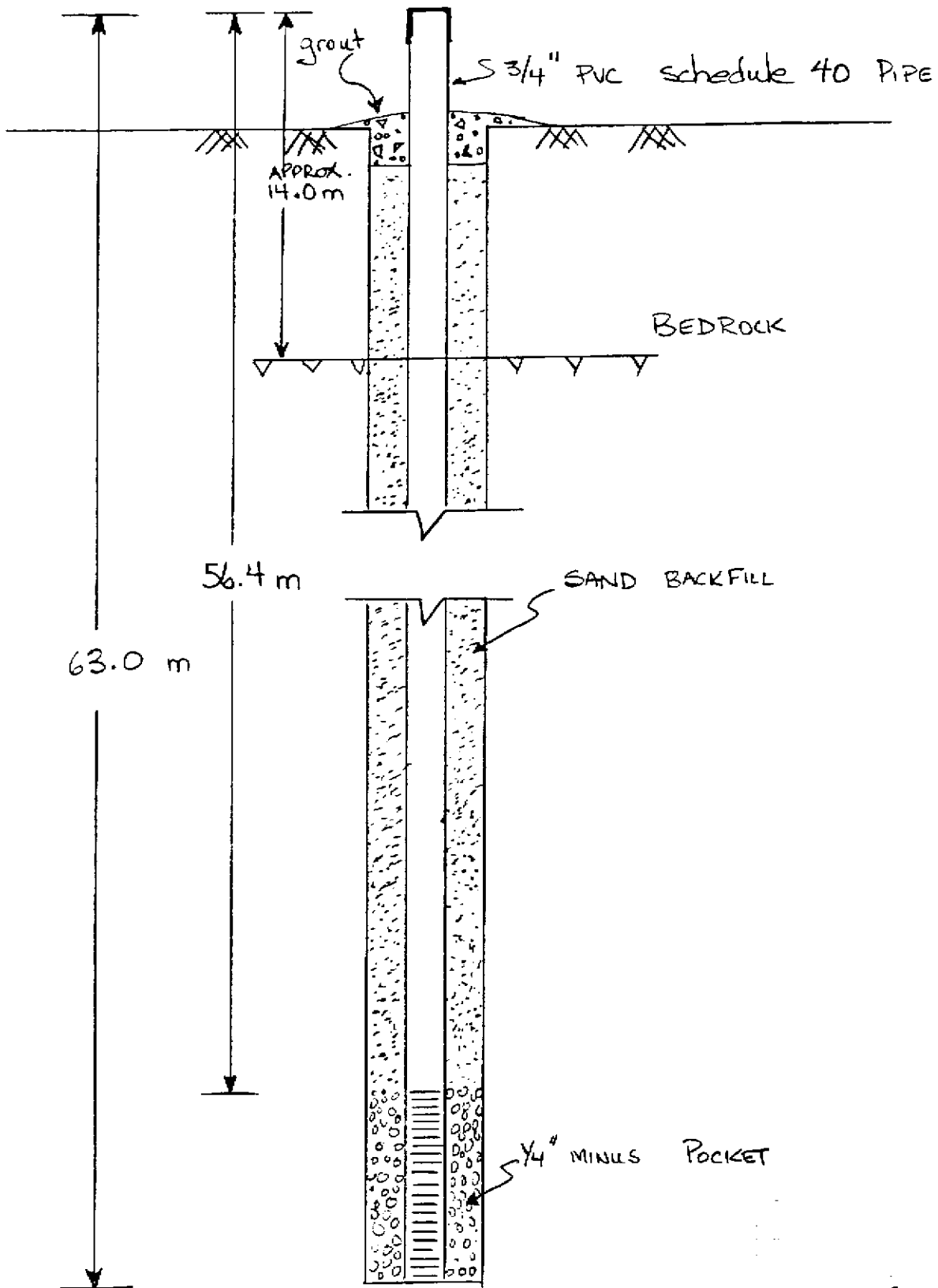

NOTE: N.T.S.

DATE: JUNE 11/83  
LOCATION: TELKINA  
INSTALLED BY: J. PITCHKO  
& D. HANDY

Report on the Sealing of Drillholes

Inspection District #9 Date of Report JUNE 13/83  
Company CROWS NEST RESOURCES LTD Land District COAST #9  
Coal Map Number 101 Licence Number L 391

- 1. Number of Drillhole 313 Bags of Cement
- 2. Surface elevation 750.6
- 3. Type (Vertical, diamond, rotary, size etc.) VERTICAL DIAMOND NO
- 4. Drilled by: Name of Contractor: J. T. THOMAS DIAMOND DRILLING LTD  
Name of Exploration Company CROWS NEST RESOURCES LTD
- 5. Date of Completion: 06-12-83
- 6. Date of Sealing:
- 7. Sealed by: Name of Contractor: J. T. THOMAS DIAMOND DRILLING LTD  
Name of Exploration Company CROWS NEST RESOURCES LTD
- 8. (a) Has any casing, drill pipe, drill bits, core barrel, etc. been left in the hole  
(b) If so, give details and location: Piezometer installed in hole see attached diagram for details
- 9. (a) Was the drillhole sealed in the manner outlined in the Chief Inspectors Instructions? No  
(b) If no, give reasons and details of variation: This drill hole is being used to collect ground water data.
- 10. (a) Was the sealing effective?  
(b) Details of any tests carried out:

11. I certify that the above drillhole has been effectively sealed in accordance with the instructions of the Chief Inspector of Mines.

Signature: Robert H. ...  
Designation: Field Coordinator  
Date: 06-13-83  
Countersignature: ...  
Designation: Operations Manager  
Date: 06-13-83

239

STAND PIPE  
PIEZOMETER INSTALLATION @ DA 313

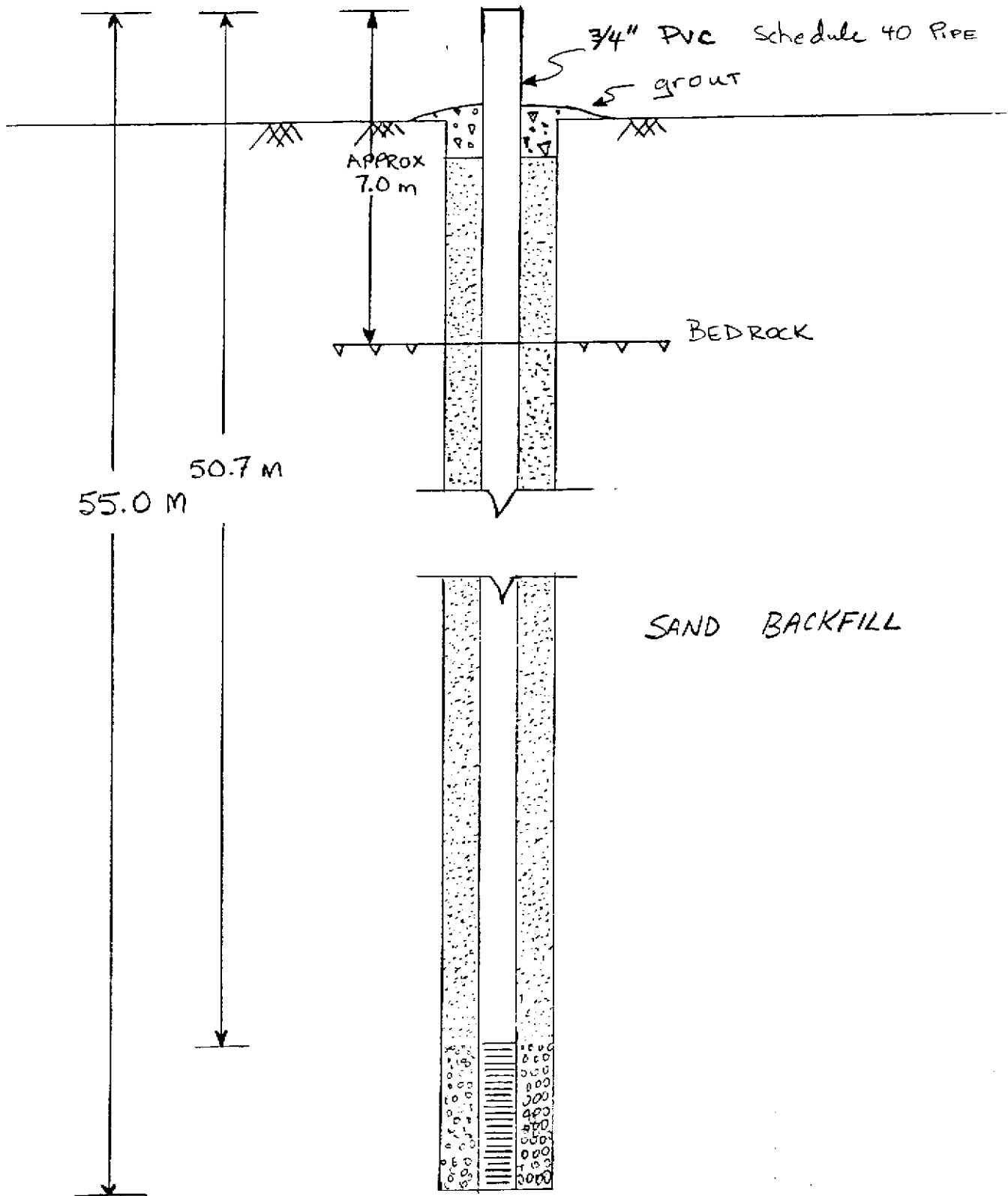

NOTE: N.T.S.

Date: JUNE 12/83  
LOCATION: TELKWA  
INSTALLED By: J. PITCHKO  
& J. KNUTSON

Report on the Sealing of Drillholes

Inspection District # 9 Date of Report JUNE 14 1983

Company CROWS NEST RESOURCES LTD Land District COAST #5

Coal Map Number 101 Licence Number L 401

1. Number of Drillhole 314 Bags of Cement 8

2. Surface elevation 723.9

3. Type (Vertical, diamond, rotary, size etc.) VERTICAL DIAMOND NR

4. Drilled by: Name of Contractor: J. T. THOMAS DIAMOND DRILLING LTD

Name of Exploration Company CROWS NEST RESOURCES LTD

5. Date of Completion: 06-12-83

6. Date of Sealing: 06-13-83

7. Sealed by: Name of Contractor: J. T. THOMAS DIAMOND DRILLING LTD

Name of Exploration Company CROWS NEST RESOURCES LTD

8. (a) Has any casing, drill pipe, drill bits, core barrel, etc. been left in the hole

(b) If so, give details and location: No materials left down hole

9. (a) Was the drillhole sealed in the manner outlined in the Chief Inspectors Instructions? Yes

(b) If no, give reasons and details of variation:

10. (a) Was the sealing effective? Yes

(b) Details of any tests carried out:

11. I certify that the above drillhole has been effectively sealed in accordance with the instructions of the Chief Inspector of Mines.

Signature: Robert A. ...

Designation: Field Coordinator

Date: 06-14-83

Countersignature: ...

Designation: Operations Manager

Date: 06-14-83

239

Report on the Sealing of Drillholes

Inspection District #9 Date of Report JUNE 14-83

Company CROWS NEST RESOURCES LTD Land District COAST # 5

Coal Map Number 101 Licence Number L 401

1. Number of Drillhole 315 Bags of Cement 10

2. Surface elevation 735.0

3. Type (Vertical, diamond, rotary, size etc.) Vertical Diamond NQ

4. Drilled by: Name of Contractor: J. T. THOMAS DIAMOND DRILLING LTD

Name of Exploration Company CROWS NEST RESOURCES LTD

5. Date of Completion: 06-13-83

6. Date of Sealing: 06-13-83

7. Sealed by: Name of Contractor: J. T. THOMAS DIAMOND DRILLING LTD

Name of Exploration Company CROWS NEST RESOURCES LTD

8. (a) Has any casing, drill pipe, drill bits, core barrel, etc. been left in the hole

(b) If so, give details and location: No materials left down the

hole

9. (a) Was the drillhole sealed in the manner outlined in the Chief Inspectors Instructions? Yes

(b) If no, give reasons and details of variation:

10. (a) Was the sealing effective? Yes

(b) Details of any tests carried out:

11. I certify that the above drillhole has been effectively sealed in accordance with the instructions of the Chief Inspector of Mines.

Signature: Robert Anello

Designation: Field Coordinator

Date: 06-14-83

Countersignature: Ian Blair

Designation: OPERATIONS MANAGER

Date: 06-14-83

239

Report on the Sealing of Drillholes

Inspection District # 9 Date of Report JUNE 15 / 83

Company CROWS NEST RESOURCES LTD Land District COAST # 5

Coal Map Number 101 Licence Number L 401

1. Number of Drillhole 316 Bags of Cement 10

2. Surface elevation 712.8

3. Type (Vertical, diamond, rotary, size etc. Vertical Diamond NA

4. Drilled by: Name of Contractor: J. T. THOMAS DIAMOND DRILLING LTD

Name of Exploration Company CROWS NEST RESOURCES LTD

5. Date of Completion: 06-14-83

6. Date of Sealing: 06-14-83

7. Sealed by: Name of Contractor: J. T. THOMAS DIAMOND DRILLING LTD

Name of Exploration Company CROWS NEST RESOURCES LTD

8. (a) Has any casing, drill pipe, drill bits, core barrel, etc. been left in the hole?

(b) If so, give details and location: No materials left down hole

9. (a) Was the drillhole sealed in the manner outlined in the Chief Inspectors Instructions? Yes

(b) If no, give reasons and details of variation:

10. (a) Was the sealing effective? Yes

(b) Details of any tests carried out:

11. I certify that the above drillhole has been effectively sealed in accordance with the instructions of the Chief Inspector of Mines.

Signature: [Handwritten Signature]

Designation: Field Coordinator

Date: 06-15-83

Countersignature: [Handwritten Signature]

Designation: Operations Manager

Date: 06-15-83

239

Report on the Sealing of Drillholes

Inspection District #9 Date of Report JUNE 17/83  
Company CROWS NEST RESOURCES LTD Land District COAST #5  
Coal Map Number 101 Licence Number L 401

1. Number of Drillhole 317 Bags of Cement 12  
2. Surface elevation 713.7  
3. Type (Vertical, diamond, rotary, size etc.) Vertical Diamond NR  
4. Drilled by: Name of Contractor: J. T. THOMAS DIAMOND DRILLING LTD  
Name of Exploration Company CROWS NEST RESOURCES LTD

5. Date of Completion: 06-15-83

6. Date of Sealing: 06-15-83

7. Sealed by: Name of Contractor: J. T. THOMAS DIAMOND DRILLING LTD  
Name of Exploration Company CROWS NEST RESOURCES LTD

8. (a) Has any casing, drill pipe, drill bits, core barrel, etc. been left in the hole?  
(b) If so, give details and location: No material left down hole

9. (a) Was the drillhole sealed in the manner outlined in the Chief Inspectors Instructions? Yes  
(b) If no, give reasons and details of variation:

10. (a) Was the sealing effective? Yes  
(b) Details of any tests carried out:

11. I certify that the above drillhole has been effectively sealed in accordance with the instructions of the Chief Inspector of Mines.

Signature: Robert A. Hallett  
Designation: Field Coordinator  
Date: 06-17-83  
Countersignature: Jim Baker  
Designation: Operations Manager  
Date: 06-17-83

239

Report on the Sealing of Drillholes

Inspection District #9 Date of Report JUNE 18 1983  
Company CROWS NEST RESOURCES LTD Land District COAST NS  
Coal Map Number 101 Licence Number L 401

1. Number of Drillhole 318 Bags of Cement 2  
2. Surface elevation 684.6  
3. Type (Vertical, diamond, rotary, size etc.) Vertical Diamond NQ  
4. Drilled by: Name of Contractor: J. T. THOMAS DIAMOND DRILLING LTD  
Name of Exploration Company CROWS NEST RESOURCES LTD

5. Date of Completion: 06-17-83  
6. Date of Sealing: \_\_\_\_\_

7. Sealed by: Name of Contractor: J. T. THOMAS DIAMOND DRILLING LTD  
Name of Exploration Company CROWS NEST RESOURCES LTD

8. (a) Has any casing, drill pipe, drill bits, core barrel, etc. been left in the hole?  
(b) If so, give details and location: A piezometer has been installed in this hole see attached diagram

9. (a) Was the drillhole sealed in the manner outlined in the Chief Inspectors Instructions? No  
(b) If no, give reasons and details of variation: This hole is being used to observe and gather ground water information

10. (a) Was the sealing effective? \_\_\_\_\_  
(b) Details of any tests carried out: \_\_\_\_\_

11. I certify that the above drillhole has been effectively sealed in accordance with the instructions of the Chief Inspector of Mines.

Signature: [Signature]  
Designation: Field Coordinator  
Date: 06-18-83  
Countersignature: [Signature]  
Designation: Operations Manager  
Date: 06-20-83

**239**



# PIEZOMETER INSTALLATION @ D.H. 318

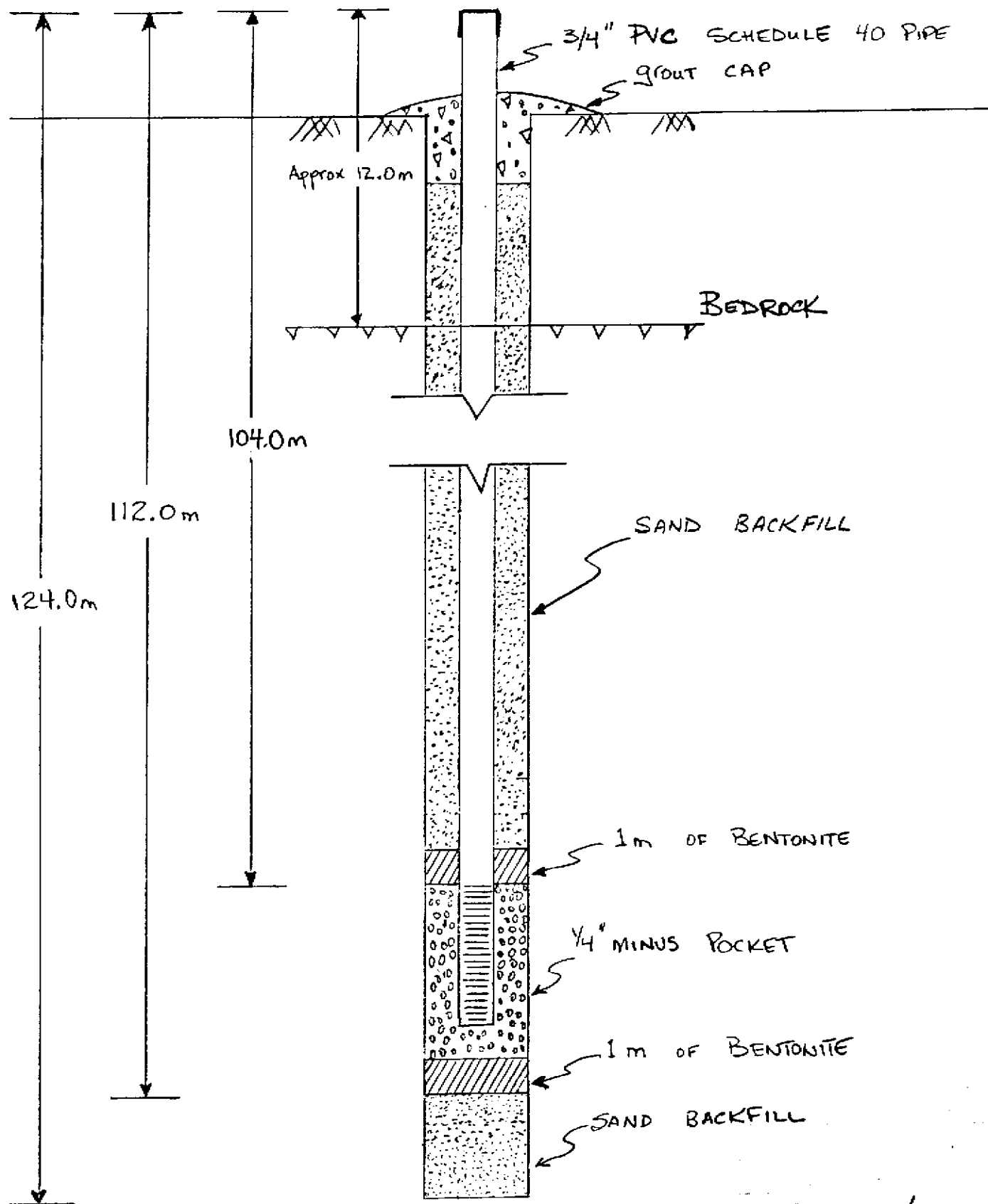

NOTE : N.T.S.

DATE : JUNE 16 /83  
 LOCATION : TELKWA  
 INSTALLED BY : J. PITCHKO &  
 J. KNUTSON

Report on the Sealing of Drillholes

Inspection District # 9 Date of Report JUNE 18 / 83

Company CROWS NEST RESOURCES LTD Land District COAST # 5

Coal Map Number 101 Licence Number L 391

1. Number of Drillhole 319 Bags of Cement 9

2. Surface elevation 772.4

3. Type (Vertical, diamond, rotary, size etc. VERTICAL DIAMOND NQ

4. Drilled by: Name of Contractor: J. T. THOMAS DIAMOND DRILLING LTD  
Name of Exploration Company CROWS NEST RESOURCES LTD

5. Date of Completion: 06-17-83

6. Date of Sealing: 06-17-83

7. Sealed by: Name of Contractor: J. T. THOMAS DIAMOND DRILLING LTD  
Name of Exploration Company CROWS NEST RESOURCES LTD

8. (a) Has any casing, drill pipe, drill bits, core barrel, etc. been left in the hole

(b) If so, give details and location: No materials left down the hole

9. (a) Was the drillhole sealed in the manner outlined in the Chief Inspectors Instructions? Yes

(b) If no, give reasons and details of variation:

10. (a) Was the sealing effective? yes

(b) Details of any tests carried out:

11. I certify that the above drillhole has been effectively sealed in accordance with the instructions of the Chief Inspector of Mines.

Signature: [Handwritten Signature]

Designation: Field Coordinator

Date: 06-18-83

Countersignature: [Handwritten Signature]

Designation: Operations Manager

Date: 06-20-83

239

Report on the Sealing of Drillholes

Inspection District #9 Date of Report JUNE 11 1983

Company CROWS NEST RESOURCES LTD Land District COAST #5

Coal Map Number 101 Licence Number CL 3876

1. Number of Drillhole 321 Bags of Cement 13

2. Surface elevation 790.1

3. Type (Vertical, diamond, rotary, size etc.) VERTICAL DIAMOND NA

4. Drilled by: Name of Contractor: J. T. THOMAS DIAMOND DRILLING LTD

Name of Exploration Company CROWS NEST RESOURCES LTD

5. Date of Completion: 06-20-83

6. Date of Sealing: 06-20-83

7. Sealed by: Name of Contractor: J. T. THOMAS DIAMOND DRILLING LTD

Name of Exploration Company CROWS NEST RESOURCES LTD

8. (a) Has any casing, drill pipe, drill bits, core barrel, etc. been left in the hole?

(b) If so, give details and location: No materials left down hole

9. (a) Was the drillhole sealed in the manner outlined in the Chief Inspectors Instructions? yes

(b) If no, give reasons and details of variation: \_\_\_\_\_

10. (a) Was the sealing effective? yes

(b) Details of any tests carried out: \_\_\_\_\_

11. I certify that the above drillhole has been effectively sealed in accordance with the instructions of the Chief Inspector of Mines.

Signature: Robert A. Hullo

Designation: FIELD COORDINATOR

Date: 06-21-83

Countersignature: Len Bell

Designation: OPERATIONS MANAGER

Date: 06-23-83

239

Report on the Sealing of Drillholes

Inspection District #9 Date of Report JUNE 20/83

Company CROWS NEST RESOURCES LTD Land District COAST #5

Coal Map Number 101 Licence Number CL 3876

1. Number of Drillhole 320 Bags of Cement 17

2. Surface elevation 772.0

3. Type (Vertical, diamond, rotary, size etc.) VERTICAL DIAMOND NR

4. Drilled by: Name of Contractor: J. T. THOMAS DIAMOND DRILLING LTD

Name of Exploration Company CROWS NEST RESOURCES LTD

5. Date of Completion: 06-19-83

6. Date of Sealing: 06-19-83

7. Sealed by: Name of Contractor: J. T. THOMAS DIAMOND DRILLING LTD

Name of Exploration Company CROWS NEST RESOURCES LTD

8. (a) Has any casing, drill pipe, drill bits, core barrel, etc. been left in the hole

(b) If so, give details and location: left in hole 1 over shot at 86.8 m and 61 m of wire line

9. (a) Was the drillhole sealed in the manner outlined in the Chief Inspectors Instructions? No

(b) If no, give reasons and details of variation: Drill pipe could not get by the cable and over shot. Pipe placed at 60 m and cemented back to surface.

10. (a) Was the sealing effective? Yes

(b) Details of any tests carried out: \_\_\_\_\_

11. I certify that the above drillhole has been effectively sealed in accordance with the instructions of the Chief Inspector of Mines.

Signature: [Signature]

Designation: FIELD COORDINATOR

Date: 06-20-83

Countersignature: [Signature]

Designation: OPERATIONS MANAGER

Date: 06-20-83

239

Report on the Sealing of Drillholes

Inspection District #9 Date of Report JUNE 23-83

Company CROWS NEST RESOURCES LTD Land District COAST #5

Coal Map Number 101 Licence Number CL 3876

1. Number of Drillhole 322 Bags of Cement 20

2. Surface elevation 768.8

3. Type (Vertical, diamond, rotary, size etc.) VERT NR

4. Drilled by: Name of Contractor: J. T. THOMAS DIAMOND DRILLING LTD

Name of Exploration Company CROWS NEST RESOURCES LTD

5. Date of Completion: 06-21-83

6. Date of Sealing: 06-21-83

7. Sealed by: Name of Contractor: J. T. THOMAS DIAMOND DRILLING LTD

Name of Exploration Company CROWS NEST RESOURCES LTD

8. (a) Has any casing, drill pipe, drill bits, core barrel, etc. been left in the hole

(b) If so, give details and location: No materials left in hole

9. (a) Was the drillhole sealed in the manner outlined in the Chief Inspectors Instructions? Yes

(b) If no, give reasons and details of variation: \_\_\_\_\_

10. (a) Was the sealing effective? Yes

(b) Details of any tests carried out: \_\_\_\_\_

11. I certify that the above drillhole has been effectively sealed in accordance with the instructions of the Chief Inspector of Mines.

Signature: Robert Hutto

Designation: FIELD COORDINATOR

Date: 06-23-83

Countersignature: Jim Baker

Designation: OPERATIONS MANAGER

Date: 06-23-83

239

Report on the Sealing of Drillholes

Inspection District # 9 Date of Report JUNE 26/83

Company CROWS NEST RESOURCES LTD Land District COAST #5

Coal Map Number 101 Licence Number CL 3876

1. Number of Drillhole 323 Bags of Cement -

2. Surface elevation 769.7

3. Type (Vertical, diamond, rotary, size etc. DIAMOND NR VERTICAL

4. Drilled by: Name of Contractor: J. T. THOMAS DIAMOND DRILLING LTD

Name of Exploration Company CROWS NEST RESOURCES LTD

5. Date of Completion: 06-24-83

6. Date of Sealing:

7. Sealed by: Name of Contractor: J. T. THOMAS DIAMOND DRILLING LTD

Name of Exploration Company CROWS NEST RESOURCES LTD

8. (a) Has any casing, drill pipe, drill bits, core barrel, etc. been left in the ho

(b) If so, give details and location: Piezometer installed in this hole. See attached diagram for details

9. (a) Was the drillhole sealed in the manner outlined in the Chief Inspectors Instructions? No

(b) If no, give reasons and details of variation: This hole is being used to test and monitor ground water

10. (a) Was the sealing effective?

(b) Details of any tests carried out:

11. I certify that the above drillhole has been effectively sealed in accordance with the instructions of the Chief Inspector of Mines.

Signature: Robert A. Hutto

Designation: Field Coordinator

Date: 06-26-83

Countersignature: Len Bohlen

Designation: OPERATIONS MANAGER

Date: 06-27-83

239

# PIEZOMETER INSTALLATION @ D.H. 323

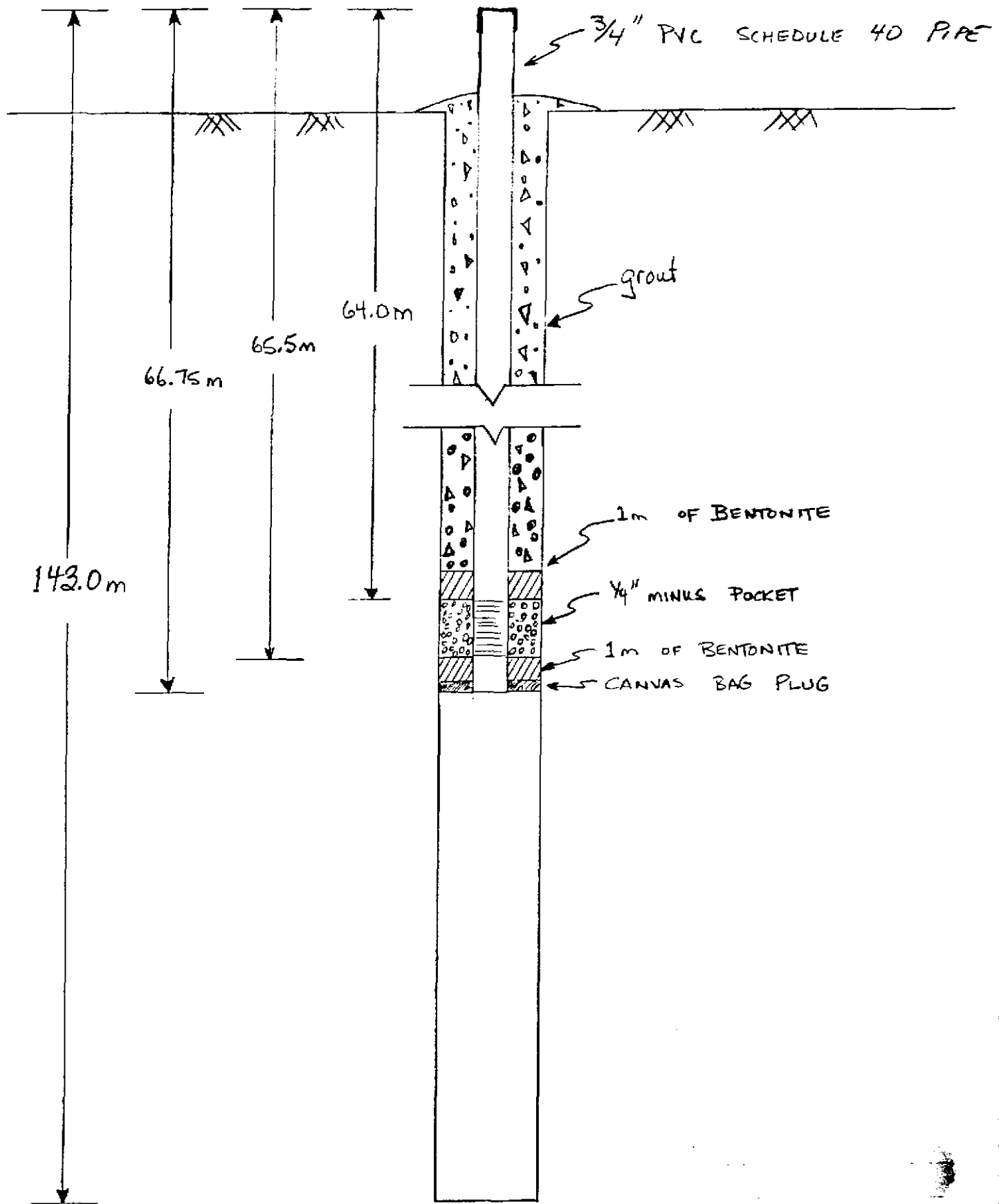

NOTE : N.T.S.  
 55.0 m OF CASING  
 WAS REQUIRED (BADLY BROKEN)

DATE : JUNE 23 & 24 / 83  
 LOCATION : TELKWA  
 INSTALLED BY : B. SANDEN  
 & J. EISENMAN

Report on the Sealing of Drillholes

Inspection District #9 Date of Report JUNE 26 1983  
Company CROWS NEST RESOURCES LTD Land District COAST #5  
Coal Map Number 101 Licence Number L391

1. Number of Drillhole 324 Bags of Cement 7

2. Surface elevation 788.5

3. Type (Vertical, diamond, rotary, size etc.) VERTICAL DIAMOND NR

4. Drilled by: Name of Contractor: J. T. THOMAS DIAMOND DRILLING LTD  
Name of Exploration Company CROWS NEST RESOURCES LTD

5. Date of Completion: 06-25-83

6. Date of Sealing: 06-25-83

7. Sealed by: Name of Contractor: J. T. THOMAS DIAMOND DRILLING LTD  
Name of Exploration Company CROWS NEST RESOURCES LTD

8. (a) Has any casing, drill pipe, drill bits, core barrel, etc. been left in the hole

(b) If so, give details and location: 1- 5' piece of casing  
left 2m from surface

9. (a) Was the drillhole sealed in the manner outlined in the Chief Inspectors  
Instructions? Yes

(b) If no, give reasons and details of variation:

10. (a) Was the sealing effective? Yes

(b) Details of any tests carried out:

11. I certify that the above drillhole has been effectively sealed in accordance with  
the instructions of the Chief Inspector of Mines.

Signature: Robert Ault

Designation: FIELD COORDINATOR

Date: 06-26-83

Countersignature: Len Palmer

Designation: Operations Manager

Date: 06-27-83

239



Report on the Sealing of Drillholes

Inspection District # 9 Date of Report JUNE 27 1983

Company CROWS NEST RESOURCES LTD Land District COAST #5

Coal Map Number 101 Licence Number L 391

1. Number of Drillhole 325 Bags of Cement \_\_\_\_\_

2. Surface elevation 803.1

3. Type (Vertical, diamond, rotary, size etc.) \_\_\_\_\_

4. Drilled by: Name of Contractor: J. T. THOMAS DIAMOND DRILLING LTD  
Name of Exploration Company CROWS NEST RESOURCES LTD

5. Date of Completion: 06-26-83

6. Date of Sealing: \_\_\_\_\_

7. Sealed by: Name of Contractor: J. T. THOMAS DIAMOND DRILLING LTD  
Name of Exploration Company CROWS NEST RESOURCES LTD

8. (a) Has any casing, drill pipe, drill bits, core barrel, etc. been left in the hole? \_\_\_\_\_

(b) If so, give details and location: A piezometer has been installed in this hole. See attached for details

9. (a) Was the drillhole sealed in the manner outlined in the Chief Inspectors Instructions? No

(b) If no, give reasons and details of variation: This hole is being used to monitor and test ground water

10. (a) Was the sealing effective? \_\_\_\_\_

(b) Details of any tests carried out: \_\_\_\_\_

11. I certify that the above drillhole has been effectively sealed in accordance with the instructions of the Chief Inspector of Mines.

Signature: [Handwritten Signature]

Designation: Field Coordinator

Date: 06-27-83

Countersignature: [Handwritten Signature]

Designation: Operations Manager

Date: 06-27-83

**239**

# PIEZOMETER INSTALLATION @ D.H. 325

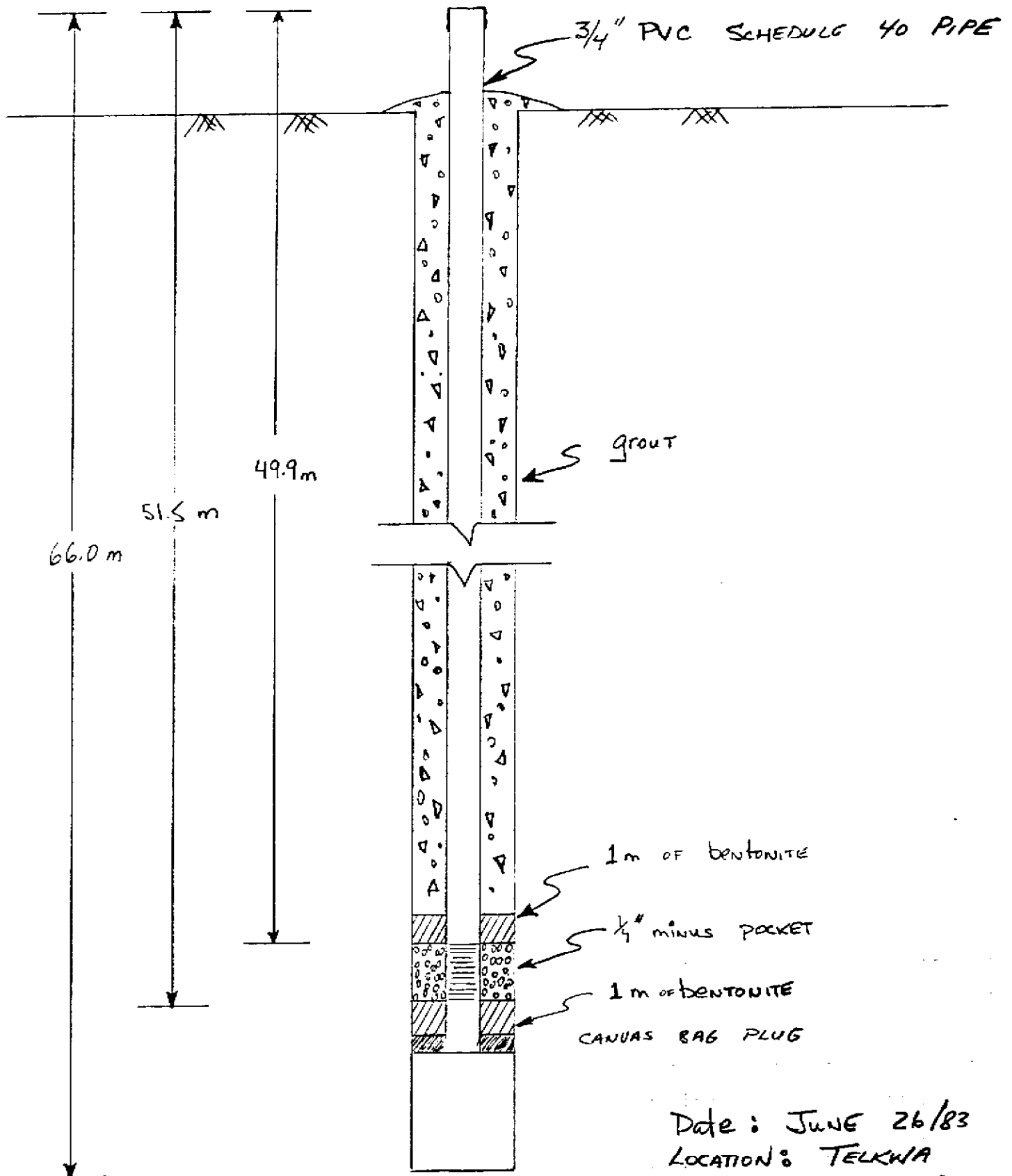

NOTE: N.T.S.  
28 m OF CASING  
WAS REQUIRED

Date: JUNE 26/83  
LOCATION: TELKWA  
INSTALLED BY: B. SANDEN  
& A. RUDKAUICH.  
(J.T. THOMAS)  
DRILLER.

Report on the Sealing of Drillholes

Inspection District #9 Date of Report JUNE 29 1983  
Company CROWS NEST RESOURCES LTD Land District COAST #5  
Coal Map Number 101 Licence Number L 391

1. Number of Drillhole 326 Bags of Cement 10  
2. Surface elevation 792.8  
3. Type (Vertical, diamond, rotary, size etc.) Vertical Diamond AQ  
4. Drilled by: Name of Contractor: J. T. THOMAS DIAMOND DRILLING LTD  
Name of Exploration Company CROWS NEST RESOURCES LTD

5. Date of Completion: 06-28-83  
6. Date of Sealing: 06-28-83

7. Sealed by: Name of Contractor: J. T. THOMAS DIAMOND DRILLING LTD  
Name of Exploration Company CROWS NEST RESOURCES LTD

8. (a) Has any casing, drill pipe, drill bits, core barrel, etc. been left in the hole?  
(b) If so, give details and location: No materials left down hole

9. (a) Was the drillhole sealed in the manner outlined in the Chief Inspectors Instructions? Yes  
(b) If no, give reasons and details of variation:

10. (a) Was the sealing effective? Yes  
(b) Details of any tests carried out:

11. I certify that the above drillhole has been effectively sealed in accordance with the instructions of the Chief Inspector of Mines.

Signature: [Handwritten Signature]  
Designation: Field Coordinator  
Date: 06-29-83  
Countersignature: [Handwritten Signature]  
Designation: Operations Manager  
Date: 06-29-83

239

Report on the Sealing of Drillholes

Inspection District #9 Date of Report July 2/83

Company CROWS NEST RESOURCES LTD Land District COAST #5

Coal Map Number 101 Licence Number 6391

1. Number of Drillhole 328 Bags of Cement 10

2. Surface elevation 832.6

3. Type (Vertical, diamond, rotary, size etc.) Vertical Diamond NA

4. Drilled by: Name of Contractor: J. T. THOMAS DIAMOND DRILLING LTD

Name of Exploration Company CROWS NEST RESOURCES LTD

5. Date of Completion: 07-01-83

6. Date of Sealing: 07-01-83

7. Sealed by: Name of Contractor: J. T. THOMAS DIAMOND DRILLING LTD

Name of Exploration Company CROWS NEST RESOURCES LTD

8. (a) Has any casing, drill pipe, drill bits, core barrel, etc. been left in the hole

(b) If so, give details and location: No materials left down the hole

9. (a) Was the drillhole sealed in the manner outlined in the Chief Inspectors Instructions? Yes

(b) If no, give reasons and details of variation: \_\_\_\_\_

10. (a) Was the sealing effective? Yes

(b) Details of any tests carried out: \_\_\_\_\_

11. I certify that the above drillhole has been effectively sealed in accordance with the instructions of the Chief Inspector of Mines.

Signature: Robert Pardo

Designation: FIELD COORDINATOR

Date: 07-02-83

Countersignature: Alan Fisher

Designation: OPERATIONS MANAGER

Date: 07-04-83

**239**

Report on the Sealing of Drillholes

Inspection District 19 Date of Report JULY 5 1987  
Company CROWS NEST RESOURCES LTD Land District COAST #5  
Coal Map Number 101 Licence Number CL3877

1. Number of Drillhole 329 Bags of Cement 26  
2. Surface elevation 863.5  
3. Type (Vertical, diamond, rotary, size etc.) ND  
4. Drilled by: Name of Contractor: J. T. THOMAS DIAMOND DRILLING LTD  
Name of Exploration Company CROWS NEST RESOURCES LTD

5. Date of Completion: 07-04-83  
6. Date of Sealing: 07-04-83

7. Sealed by: Name of Contractor: J. T. THOMAS DIAMOND DRILLING LTD  
Name of Exploration Company CROWS NEST RESOURCES LTD

8. (a) Has any casing, drill pipe, drill bits, core barrel, etc. been left in the hole?  
(b) If so, give details and location: No materials left down the hole

9. (a) Was the drillhole sealed in the manner outlined in the Chief Inspectors Instructions? yes  
(b) If no, give reasons and details of variation:

10. (a) Was the sealing effective? Yes  
(b) Details of any tests carried out:

11. I certify that the above drillhole has been effectively sealed in accordance with the instructions of the Chief Inspector of Mines.

Signature: Fabert Auelto  
Designation: Field Coordinator  
Date: 07-05-83  
Countersignature: Lin Palmer  
Designation: Operations Manager  
Date: 07-05-83

239

Report on the Sealing of Drillholes

Inspection District # 9 Date of Report JULY 7 - 1983  
Company CROWS NEST RESOURCES LTD Land District COAST # 5  
Coal Map Number 101 Licence Number CL 3876

1. Number of Drillhole 330 Bags of Cement 26  
2. Surface elevation 895.6  
3. Type (Vertical, diamond, rotary, size etc.) Vertical Diamond NQ  
4. Drilled by: Name of Contractor: J. T. THOMAS DIAMOND DRILLING LTD  
Name of Exploration Company CROWS NEST RESOURCES LTD

5. Date of Completion: 07-06-83

6. Date of Sealing: 07-06-83

7. Sealed by: Name of Contractor: J. T. THOMAS DIAMOND DRILLING LTD  
Name of Exploration Company CROWS NEST RESOURCES LTD

8. (a) Has any casing, drill pipe, drill bits, core barrel, etc. been left in the hole?  
(b) If so, give details and location: No materials left in hole

9. (a) Was the drillhole sealed in the manner outlined in the Chief Inspectors Instructions? Yes

(b) If no, give reasons and details of variation:

10. (a) Was the sealing effective? Yes

(b) Details of any tests carried out:

11. I certify that the above drillhole has been effectively sealed in accordance with the instructions of the Chief Inspector of Mines.

Signature: Robert Kuello

Designation: FIELD COORDINATOR

Date: 07-07-83

Countersignature: Jim Belen

Designation: OPERATIONS MANAGER

Date: 07-07-83

239

Report on the Sealing of Drillholes

Inspection District # 9 Date of Report JULY 9 1983  
Company CROWS NEST RESOURCES LTD Land District COAST #5  
Coal Map Number 101 Licence Number CL 3877

1. Number of Drillhole 331 Bags of Cement 18  
2. Surface elevation 858.3  
3. Type (Vertical, diamond, rotary, size etc.) NQ  
4. Drilled by: Name of Contractor: J. T. THOMAS DIAMOND DRILLING LTD  
Name of Exploration Company CROWS NEST RESOURCES LTD

5. Date of Completion: 07-08-83  
6. Date of Sealing: 07-08-83  
7. Sealed by: Name of Contractor: J. T. THOMAS DIAMOND DRILLING LTD  
Name of Exploration Company CROWS NEST RESOURCES LTD

8. (a) Has any casing, drill pipe, drill bits, core barrel, etc. been left in the hole  
(b) If so, give details and location: No materials left in hole

9. (a) Was the drillhole sealed in the manner outlined in the Chief Inspectors Instructions? Yes  
(b) If no, give reasons and details of variation:

10. (a) Was the sealing effective? Yes  
(b) Details of any tests carried out:

11. I certify that the above drillhole has been effectively sealed in accordance with the instructions of the Chief Inspector of Mines.

Signature: Robert Phelps  
Designation: FIELD COORDINATOR  
Date: 07-09-83  
Countersignature: Jim Baker  
Designation: OPERATIONS MANAGER  
Date: 07-11-83

237

Report on the Sealing of Drillholes

Inspection District 29 Date of Report JULY 10 1983

Company CROWS NEST RESOURCES LTD Land District COAST #5

Coal Map Number 101 Licence Number CL 3876

1. Number of Drillhole 332 Bags of Cement 26

2. Surface elevation 816.5

3. Type (Vertical, diamond, rotary, size etc.) Vertical Diamond NQ

4. Drilled by: Name of Contractor: J. T. THOMAS DIAMOND DRILLING LTD

Name of Exploration Company CROWS NEST RESOURCES LTD

5. Date of Completion: 07-09-83

6. Date of Sealing: 07-09-83

7. Sealed by: Name of Contractor: J. T. THOMAS DIAMOND DRILLING LTD

Name of Exploration Company CROWS NEST RESOURCES LTD

8. (a) Has any casing, drill pipe, drill bits, core barrel, etc. been left in the hole

(b) If so, give details and location: CORE BARREL AT 164. M

9. (a) Was the drillhole sealed in the manner outlined in the Chief Inspectors Instructions? Yes

(b) If no, give reasons and details of variation:

10. (a) Was the sealing effective? Yes

(b) Details of any tests carried out:

11. I certify that the above drillhole has been effectively sealed in accordance with the instructions of the Chief Inspector of Mines.

Signature: Robert Helle

Designation: FIELD COORDINATOR

Date: 07-10-83

Countersignature: Jim Baker

Designation: OPERATIONS MANAGER

Date: 07-11-83

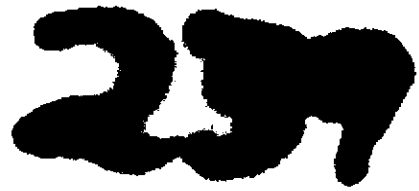



Report on the Sealing of Drillholes

Inspection District #9 Date of Report 07-15-83

Company CROWS NEST RESOURCES LTD Land District COAST #5

Coal Map Number 101 Licence Number CL 3876

1. Number of Drillhole 333 Bags of Cement

2. Surface elevation 824.5

3. Type (Vertical, diamond, rotary, size etc.) VERTICAL DIAMOND NR

4. Drilled by: Name of Contractor: J. T. THOMAS DIAMOND DRILLING LTD
Name of Exploration Company CROWS NEST RESOURCES LTD

5. Date of Completion: 07-11-83

6. Date of Sealing:

7. Sealed by: Name of Contractor: J. T. THOMAS DIAMOND DRILLING LTD
Name of Exploration Company CROWS NEST RESOURCES LTD

8. (a) Has any casing, drill pipe, drill bits, core barrel, etc. been left in the ho

(b) If so, give details and location: 9.2 M CASING AT

SURFACE

9. (a) Was the drillhole sealed in the manner outlined in the Chief Inspectors
Instructions? No

(b) If no, give reasons and details of variation: THE DRILL HOLE
WAS LEFT OPEN AS A PIEZOMETER WAS TO BE
INSTALLED. WE WERE UNABLE TO ACCESS THE LOCATION
AFTERWARDS DUE TO GROUND CONDITIONS. THIS HOLE
WILL BE SEALED DURING THE 1984 PROGRAM.

10. (a) Was the sealing effective?

(b) Details of any tests carried out:

11. I certify that the above drillhole has been effectively sealed in accordance with
the instructions of the Chief Inspector of Mines.

Signature: Robert P. Hutto

Designation: FIELD COORDINATOR

Date: 07-15-83

Countersignature: Jim Baker

Designation: Operations Manager

Date: 07-15-83



Report on the Sealing of Drillholes

Inspection District # 9 Date of Report JULY 13 / 83

Company CROWS NEST RESOURCES LTD Land District COMST # 5

Coal Map Number 101 Licence Number CL 3876

1. Number of Drillhole 334 Bags of Cement 15

2. Surface elevation 790.6

3. Type (Vertical, diamond, rotary, size etc. Vertical Diamond NA

4. Drilled by: Name of Contractor: J. T. THOMAS DIAMOND DRILLING LTD  
Name of Exploration Company CROWS NEST RESOURCES LTD

5. Date of Completion: 07-12-83

6. Date of Sealing: 07-12-83

7. Sealed by: Name of Contractor: J. T. THOMAS DIAMOND DRILLING LTD  
Name of Exploration Company CROWS NEST RESOURCES LTD

8. (a) Has any casing, drill pipe, drill bits, core barrel, etc. been left in the hole

(b) If so, give details and location: No materials left down hole

9. (a) Was the drillhole sealed in the manner outlined in the Chief Inspectors Instructions? Yes

(b) If no, give reasons and details of variation:

10. (a) Was the sealing effective? Yes

(b) Details of any tests carried out:

11. I certify that the above drillhole has been effectively sealed in accordance with the instructions of the Chief Inspector of Mines.

Signature: Robert M. ...

Designation: FIELD COORDINATOR

Date: 07-13-83

Countersignature: John Bell

Designation: OPERATIONS MANAGER

Date: 07-13-83



Report on the Sealing of Drillholes

Inspection District #9 Date of Report JULY 31 1983  
Company CROWS NEST RESOURCES LTD Land District COAST #5  
Coal Map Number 101 Licence Number CL 3876

1. Number of Drillhole 335 Bags of Cement  
2. Surface elevation 810.6  
3. Type (Vertical, diamond, rotary, size etc.) VERTICAL DIAMOND NR  
4. Drilled by: Name of Contractor: J. T. THOMAS DIAMOND DRILLING LTD  
Name of Exploration Company CROWS NEST RESOURCES LTD

5. Date of Completion: 07-17-83

6. Date of Sealing:

7. Sealed by: Name of Contractor: J. T. THOMAS DIAMOND DRILLING LTD  
Name of Exploration Company CROWS NEST RESOURCES LTD

8. (a) Has any casing, drill pipe, drill bits, core barrel, etc. been left in the hole?

(b) If so, give details and location: PIEZOMETER INSTALLATION  
SEE ATTACHED DIAGRAM FOR DETAILS

9. (a) Was the drillhole sealed in the manner outlined in the Chief Inspectors Instructions? No

(b) If no, give reasons and details of variation: The drill hole is being used to monitor and test ground water

10. (a) Was the sealing effective?

(b) Details of any tests carried out:

11. I certify that the above drillhole has been effectively sealed in accordance with the instructions of the Chief Inspector of Mines.

Signature: Robert Puello

Designation: Field Coordinator

Date: 07-31-83

Countersignature: Jim Baker

Designation: Operations Manager

Date: 08-02-83

239

bertrandite pellets coated with diesel oil + dropped down hole.  
 Sounding indicated a hang up - several drill stems  
 removed - clear obstruction.

We attempted to run a bentonite plug in place with water  
 pressure - emptied diesel coated bottles into drill then  
 pumped water - the slugs blew below the bottom of the  
 drill stem but did not seat on the filter sand.

Lowered 70 ft pipe into hole with water pressure on to  
 run plug into position + assume that plug cleaned the bottom of  
 the hole. The plug was not seated into position.  
 Water pressure added for a total of 5 minutes. Service  
 then pulled back on the pipe.

The explosive was allowed to set up + cement pumped in to close off  
 the hole. final pressure placement:

DSH 335

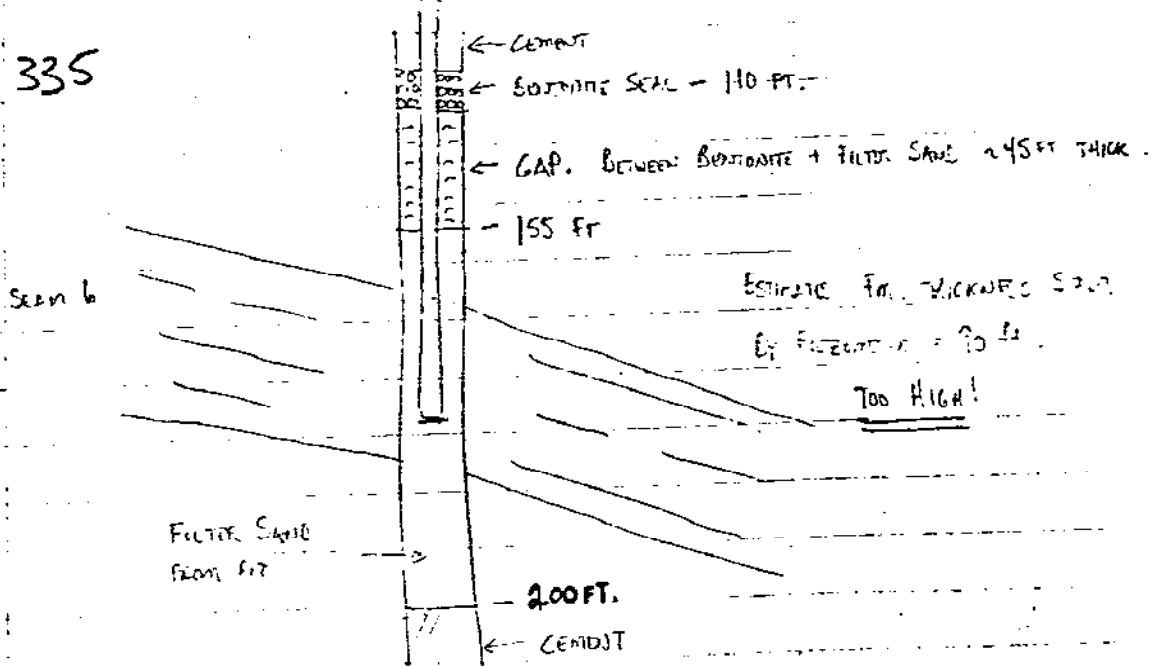

Report on the Sealing of Drillholes

Inspection District H 9 Date of Report JULY 31 1983  
Company CROWS NEST RESOURCES LTD Land District COAST #5  
Coal Map Number 101 Licence Number CL 4271

1. Number of Drillhole 336 Bags of Cement 16  
2. Surface elevation 727.7  
3. Type (Vertical, diamond, rotary, size etc.) VERTICAL DIAMOND NR  
4. Drilled by: Name of Contractor: J. T. THOMAS DIAMOND DRILLING LTD  
Name of Exploration Company CROWS NEST RESOURCES LTD

5. Date of Completion: 07-19-83  
6. Date of Sealing: 07-19-83

7. Sealed by: Name of Contractor: J. T. THOMAS DIAMOND DRILLING LTD  
Name of Exploration Company CROWS NEST RESOURCES LTD

8. (a) Has any casing, drill pipe, drill bits, core barrel, etc. been left in the hole?  
(b) If so, give details and location: No materials left down hole

9. (a) Was the drillhole sealed in the manner outlined in the Chief Inspectors Instructions? yes  
(b) If no, give reasons and details of variation: \_\_\_\_\_

10. (a) Was the sealing effective? Yes  
(b) Details of any tests carried out: \_\_\_\_\_

11. I certify that the above drillhole has been effectively sealed in accordance with the instructions of the Chief Inspector of Mines.

Signature: Robert A. Hutto  
Designation: FIELD COORDINATOR  
Date: 07-31-83  
Countersignature: John Baker  
Designation: OPERATIONS MANAGER  
Date: 08-02-83

**239**

Report on the Sealing of Drillholes

Inspection District #9 Date of Report August 1/83  
Company CROWS NEST RESOURCES LTD Land District COAST #5  
Coal Map Number 101 Licence Number CL 3876

1. Number of Drillhole 340 Bags of Cement 28  
2. Surface elevation 753.2  
3. Type (Vertical, diamond, rotary, size etc.) VERTICAL DIAMOND NA  
4. Drilled by: Name of Contractor: J. T. THOMAS DIAMOND DRILLING LTD  
Name of Exploration Company CROWS NEST RESOURCES LTD

5. Date of Completion: 07-24-83  
6. Date of Sealing: 07-24-83  
7. Sealed by: Name of Contractor: J. T. THOMAS DIAMOND DRILLING LTD  
Name of Exploration Company CROWS NEST RESOURCES LTD

8. (a) Has any casing, drill pipe, drill bits, core barrel, etc. been left in the hole?  
(b) If so, give details and location: No materials left down hole

9. (a) Was the drillhole sealed in the manner outlined in the Chief Inspectors Instructions? Yes  
(b) If no, give reasons and details of variation:

10. (a) Was the sealing effective? Yes  
(b) Details of any tests carried out:

11. I certify that the above drillhole has been effectively sealed in accordance with the instructions of the Chief Inspector of Mines.

Signature: Robert Field  
Designation: FIELD COORDINATOR  
Date: 08-01-83  
Countersignature: Ian Belton  
Designation: Operations Manager  
Date: 08-02-83

259

Report on the Sealing of Drillholes

Inspection District 49 Date of Report AUGUST 1/83

Company CROWS NEST RESOURCES LTD Land District COAST #5

Coal Map Number 101 Licence Number CL 3876

1. Number of Drillhole 341 Bags of Cement 26

2. Surface elevation 754.5

3. Type (Vertical, diamond, rotary, size etc.) VERTICAL DIAMOND NA

4. Drilled by: Name of Contractor: J. T. THOMAS DIAMOND DRILLING LTD

Name of Exploration Company CROWS NEST RESOURCES LTD

5. Date of Completion: 07-25-83

6. Date of Sealing: 07-25-83

7. Sealed by: Name of Contractor: J. T. THOMAS DIAMOND DRILLING LTD

Name of Exploration Company CROWS NEST RESOURCES LTD

8. (a) Has any casing, drill pipe, drill bits, core barrel, etc. been left in the hole?

(b) If so, give details and location: No materials left down hole

9. (a) Was the drillhole sealed in the manner outlined in the Chief Inspectors Instructions? yes

(b) If no, give reasons and details of variation:

10. (a) Was the sealing effective? Yes

(b) Details of any tests carried out:

11. I certify that the above drillhole has been effectively sealed in accordance with the instructions of the Chief Inspector of Mines.

Signature: [Signature]

Designation: FIELD COORDINATOR

Date: 08-01-83

Countersignature: [Signature]

Designation: OPERATIONS MANAGER

Date: 08-02-83

257

Report on the Sealing of Drillholes

Inspection District #9 Date of Report AUGUST 1/83  
Company CROWS NEST RESOURCES LTD Land District COAST #5  
Coal Map Number 101 Licence Number L 391

1. Number of Drillhole 342 Bags of Cement 9  
2. Surface elevation 757.5  
3. Type (Vertical, diamond, rotary, size etc.) VERTICAL DIAMOND NA  
4. Drilled by: Name of Contractor: J. T. THOMAS DIAMOND DRILLING LTD  
Name of Exploration Company CROWS NEST RESOURCES LTD

5. Date of Completion: 07-26-83  
6. Date of Sealing: 07-27-83

7. Sealed by: Name of Contractor: J. T. THOMAS DIAMOND DRILLING LTD  
Name of Exploration Company CROWS NEST RESOURCES LTD

8. (a) Has any casing, drill pipe, drill bits, core barrel, etc. been left in the hole?  
(b) If so, give details and location: PIEZOMETER HOLE SEE  
ATTACHED FOR DETAILS

9. (a) Was the drillhole sealed in the manner outlined in the Chief Inspectors  
Instructions? NO  
(b) If no, give reasons and details of variation: This hole is  
being used to test and monitor ground water

10. (a) Was the sealing effective?  
(b) Details of any tests carried out:

11. I certify that the above drillhole has been effectively sealed in accordance with  
the instructions of the Chief Inspector of Mines.

Signature: Robert Huetto  
Designation: FIELD COORDINATOR  
Date: 08-01-83  
Countersignature: [Signature]  
Designation: OPERATIONS MANAGER  
Date: 08-02-83





Final Piezometer Installation - BSH 342 Seam 5

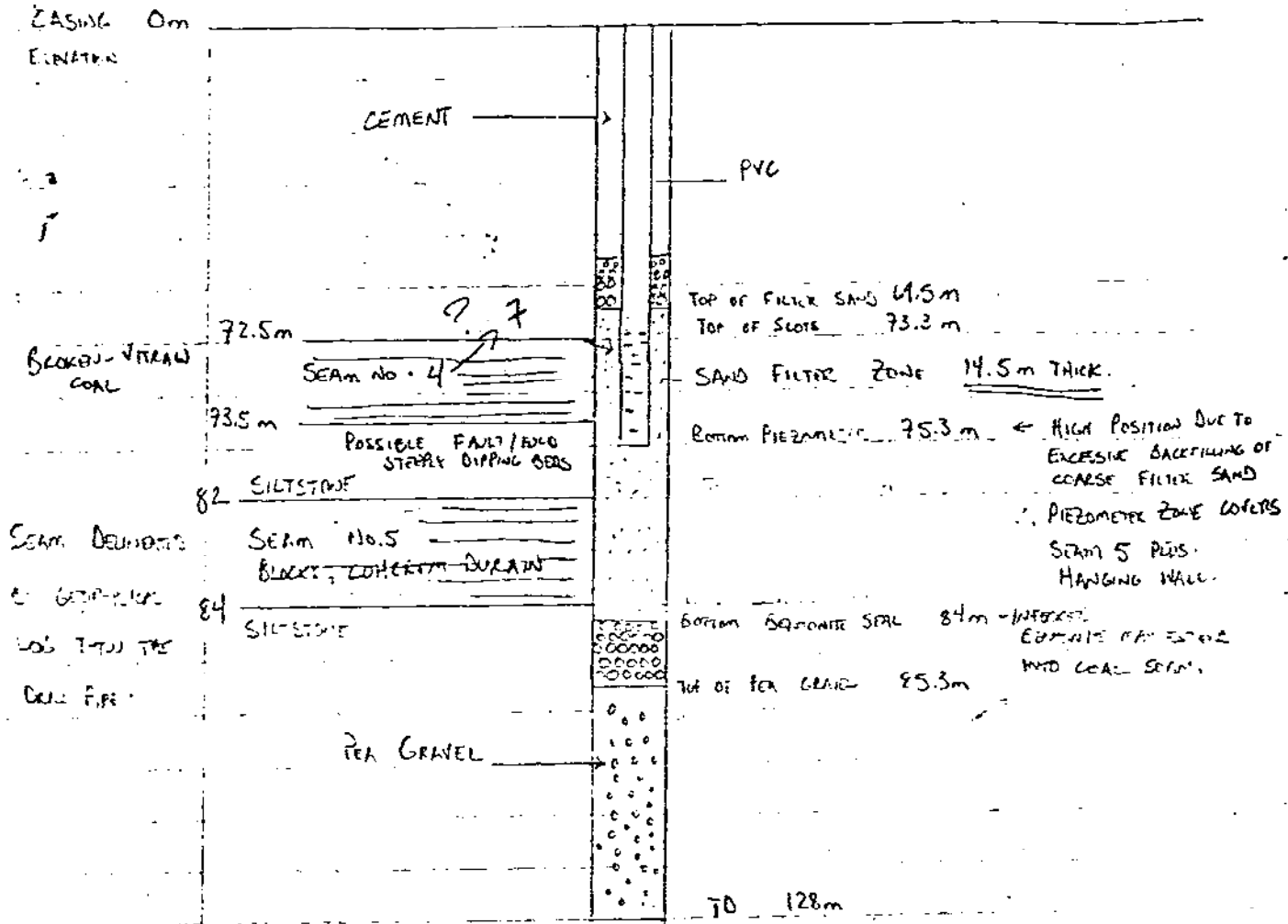

PREPARATION TIME - 1 HR.  
 INSTALLATION TIME - 4 HR.  
 CREW - AL, BRIAN  
 OBSERVERS - DENNIS, JIM.

Report on the Sealing of Drillholes

Inspection District #9 Date of Report AUGUST 1/83  
Company CROWS NEST RESOURCES LTD Land District COAST #5  
Coal Map Number 101 Licence Number CL 4271

1. Number of Drillhole 343 Bags of Cement 12  
2. Surface elevation 698.5  
3. Type (Vertical, diamond, rotary, size etc.) VERTICAL DIAMOND NO  
4. Drilled by: Name of Contractor: J.T. THOMAS DIAMOND DRILLING LTD  
Name of Exploration Company CROWS NEST RESOURCES LTD

5. Date of Completion: 07-27-83  
6. Date of Sealing: 07-28-83  
7. Sealed by: Name of Contractor: J.T. THOMAS DIAMOND DRILLING LTD  
Name of Exploration Company CROWS NEST RESOURCES LTD

8. (a) Has any casing, drill pipe, drill bits, core barrel, etc. been left in the hole?  
(b) If so, give details and location: PIEZOMETER HOLE SEE  
ATTACHED FOR DETAILS

9. (a) Was the drillhole sealed in the manner outlined in the Chief Inspectors Instructions? NO  
(b) If no, give reasons and details of variation: This hole is being used to test and monitor ground water

10. (a) Was the sealing effective?  
(b) Details of any tests carried out:

11. I certify that the above drillhole has been effectively sealed in accordance with the instructions of the Chief Inspector of Mines.

Signature: Robert P. Pello  
Designation: FIELD COORDINATOR  
Date: 08-01-83  
Countersignature: John Belton  
Designation: OPERATIONS MANAGER  
Date: 08-02-83

239

DDH 343 - FINAL PIEZOMETER INSTALLATION

NOTE - PROTECTIVE REQUIRED TO PREVENT DAMAGE  
TO CASING EQUIPMENT

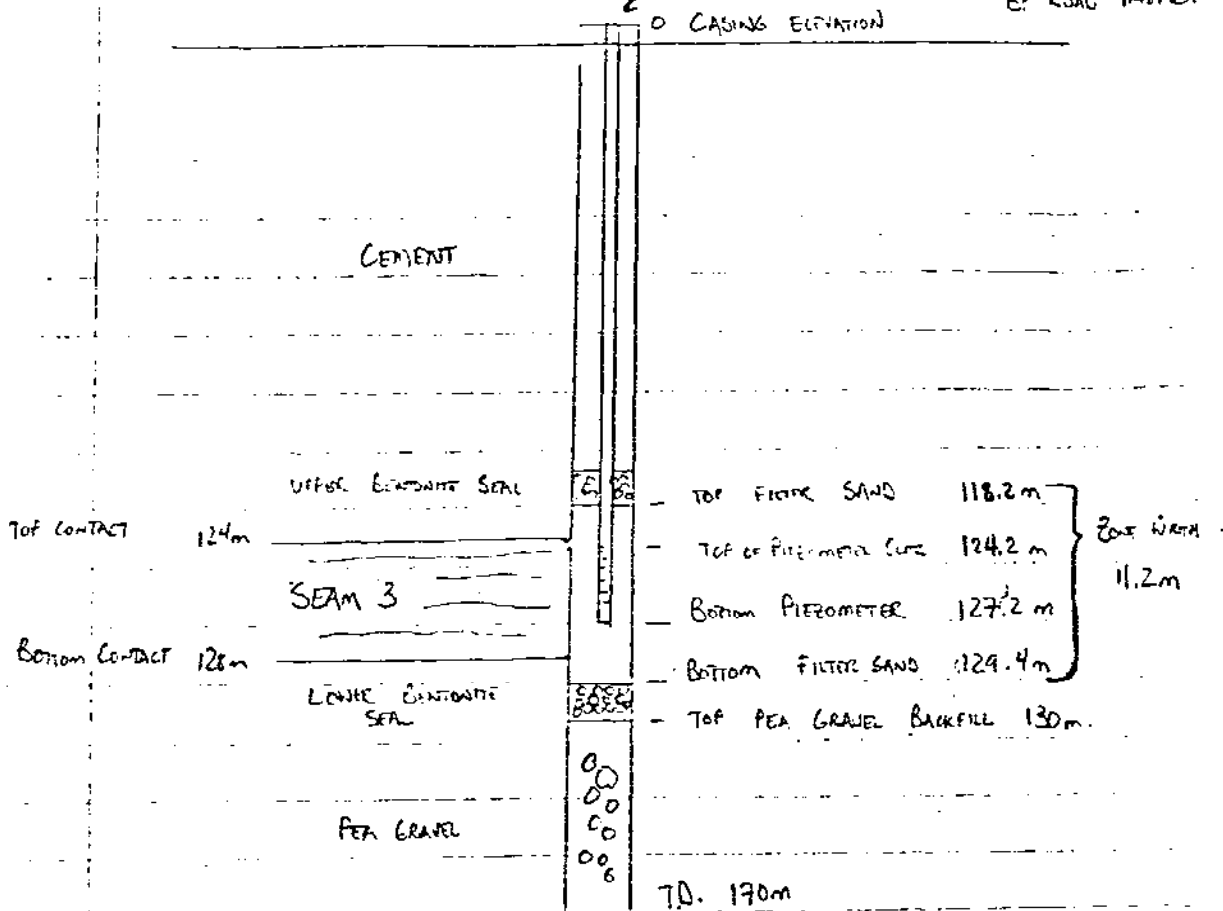

CREW - AL SPENCER, ALAN, BOB

INSTALLATION TIME - 2 1/2 HR.

REGULATION TIME - 1 HR.

Report on the Sealing of Drillholes

Inspection District #9 Date of Report AUGUST 1/83

Company CROWS NEST RESOURCES LTD Land District COAST #5

Coal Map Number 101 Licence Number CL 4271

1. Number of Drillhole 344 Bags of Cement 10

2. Surface elevation 694.3

3. Type (Vertical, diamond, rotary, size etc.) VERTICAL DIAMOND NO

4. Drilled by: Name of Contractor: J. T. THOMAS DIAMOND DRILLING LTD

Name of Exploration Company CROWS NEST RESOURCES LTD

5. Date of Completion: 07-28-83

6. Date of Sealing: 07-29-83

7. Sealed by: Name of Contractor: J. T. THOMAS DIAMOND DRILLING LTD

Name of Exploration Company CROWS NEST RESOURCES LTD

8. (a) Has any casing, drill pipe, drill bits, core barrel, etc. been left in the hole

(b) If so, give details and location: PIEZOMETER HOLE SEE

ATTACHED FOR DETAILS

9. (a) Was the drillhole sealed in the manner outlined in the Chief Inspectors Instructions? No

(b) If no, give reasons and details of variation: This hole is being used to test & monitor ground water

10. (a) Was the sealing effective? \_\_\_\_\_

(b) Details of any tests carried out: \_\_\_\_\_

11. I certify that the above drillhole has been effectively sealed in accordance with the instructions of the Chief Inspector of Mines.

Signature: [Signature]

Designation: FIELD COORDINATOR

Date: 08-01-83

Countersignature: [Signature]

Designation: OPERATIONS MANAGER

Date: 08-02-83

**239**

Final Piezometer Installation DH 314 Seam no. 2

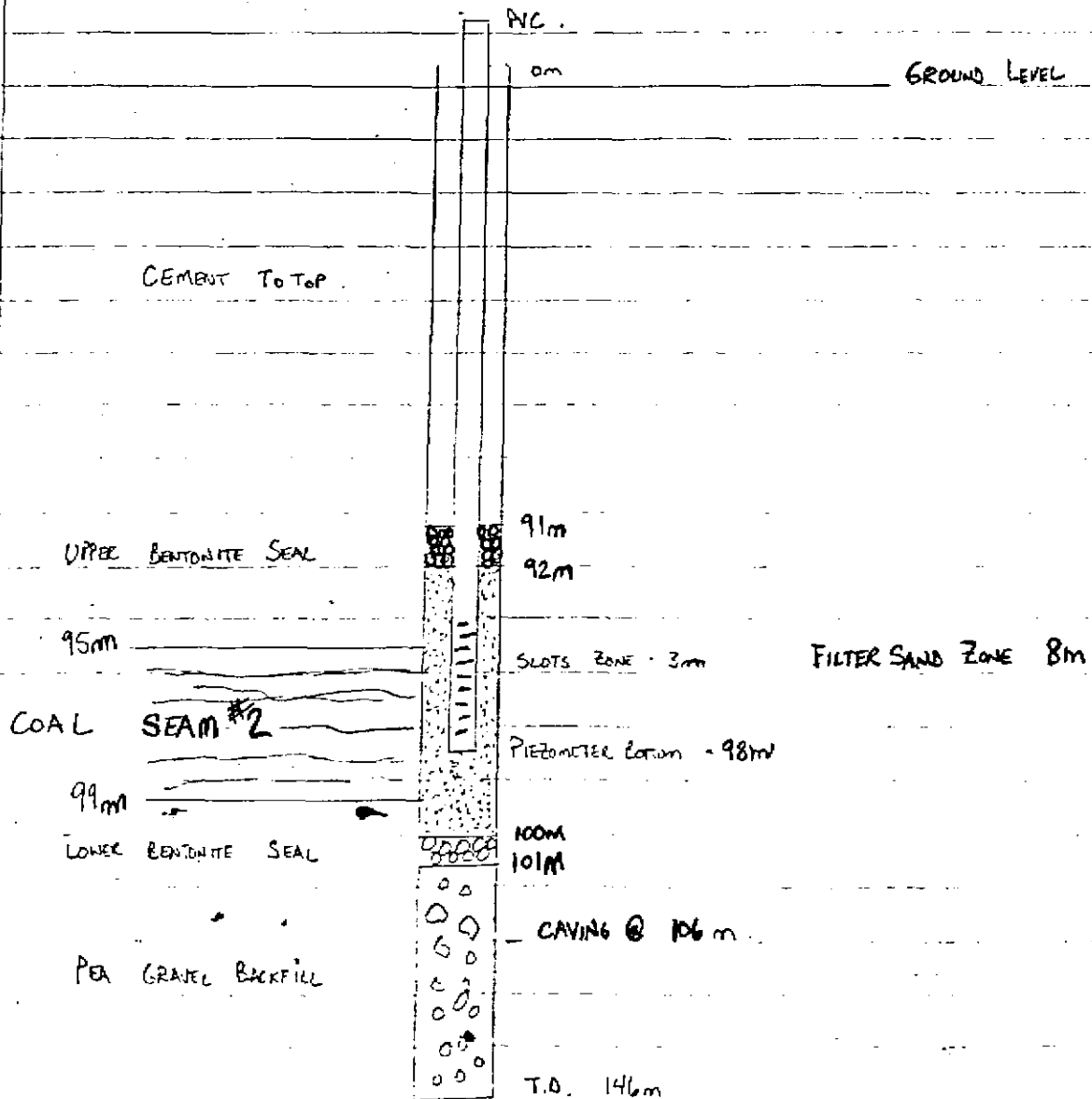

PREPARATION TIME - 1 HR.

INSTALLATION TIME - 4 HR.

CREW - AL, ALLAN, BRIAN

NOTES:

1. DRILLER'S MUST NOT DROP ROSS ONTO LOWER BENTONITE SEAL

2. USE DRY FILTER SAND ONLY - NO L.C.

Report on the Sealing of Drillholes

Inspection District 49 Date of Report AUGUST 1/83

Company CROWS NEST RESOURCES LTD Land District COAST #5

Coal Map Number 101 Licence Number CL 3709

1. Number of Drillhole 345 Bags of Cement 10

2. Surface elevation 763.5

3. Type (Vertical, diamond, rotary, size etc.) VERTICAL DIAMOND HQ

4. Drilled by: Name of Contractor: J. T. THOMAS DIAMOND DRILLING LTD  
Name of Exploration Company CROWS NEST RESOURCES LTD

5. Date of Completion: 07-30-83

6. Date of Sealing: 07-30-83

7. Sealed by: Name of Contractor: J. T. THOMAS DIAMOND DRILLING LTD  
Name of Exploration Company CROWS NEST RESOURCES LTD

8. (a) Has any casing, drill pipe, drill bits, core barrel, etc. been left in the hole?

(b) If so, give details and location: PIEZOMETER HOLE SEE ATTACHED FOR DETAILS

9. (a) Was the drillhole sealed in the manner outlined in the Chief Inspectors Instructions? No

(b) If no, give reasons and details of variation: This hole is being used to test & monitor ground water

10. (a) Was the sealing effective? \_\_\_\_\_

(b) Details of any tests carried out: \_\_\_\_\_

11. I certify that the above drillhole has been effectively sealed in accordance with the instructions of the Chief Inspector of Mines.

Signature: Robert P. [Signature]

Designation: FIELD COORDINATOR

Date: 08-01-83

Countersignature: [Signature]

Designation: OPERATIONS MANAGER

Date: 08-02-83

239

DDH 345 Final Piezometer Installation Diagram

West Gathen

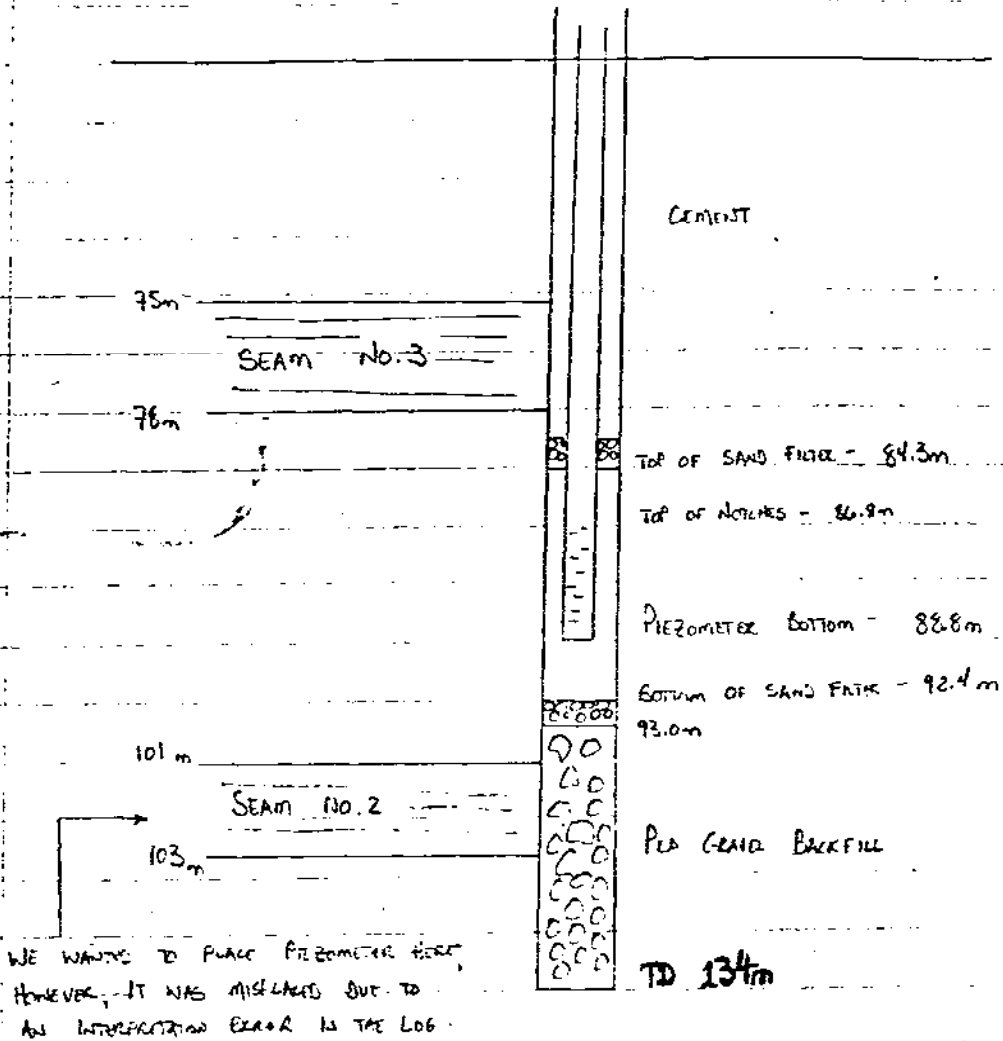

INSTALLATION TIME - 2 1/2 HC

CREW - AL + TOM

DEWIS + JIM

Report on the Sealing of Drillholes

Inspection District #9 Date of Report August 2/83

Company CROWS NEST RESOURCES LTD Land District COAST #5

Coal Map Number 101 Licence Number CL 3709

1. Number of Drillhole 346 Bags of Cement 22

2. Surface elevation 766.8

3. Type (Vertical, diamond, rotary, size etc.) VERTICAL DIAMOND NR

4. Drilled by: Name of Contractor: J. T. THOMAS DIAMOND DRILLING LTD

Name of Exploration Company CROWS NEST RESOURCES LTD

5. Date of Completion: 07-31-83

6. Date of Sealing: 08-01-83

7. Sealed by: Name of Contractor: J. T. THOMAS DIAMOND DRILLING LTD

Name of Exploration Company CROWS NEST RESOURCES LTD

8. (a) Has any casing, drill pipe, drill bits, core barrel, etc. been left in the hole

(b) If so, give details and location: CASING BETWEEN 51.8M & 70.1M

9. (a) Was the drillhole sealed in the manner outlined in the Chief Inspectors Instructions? yes

(b) If no, give reasons and details of variation:

10. (a) Was the sealing effective? yes

(b) Details of any tests carried out:

11. I certify that the above drillhole has been effectively sealed in accordance with the instructions of the Chief Inspector of Mines.

Signature: Robert A. Della

Designation: FIELD COORDINATOR

Date: 08-02-83

Countersignature: Len Fisher

Designation: OPERATIONS MANAGER

Date: 08-02-83

239



Report on the Sealing of Drillholes

Inspection District # 9 Date of Report JULY 31 / 83

Company CROWS NEST RESOURCES LTD Land District COAST #5

Coal Map Number 101 Licence Number CL 4271

1. Number of Drillhole 338 Bags of Cement 26

2. Surface elevation 742.3

3. Type (Vertical, diamond, rotary, size etc.) VERTICAL DIAMOND NR

4. Drilled by: Name of Contractor: J. T. THOMAS DIAMOND DRILLING LTD

Name of Exploration Company CROWS NEST RESOURCES LTD

5. Date of Completion: 07-22-83

6. Date of Sealing: 07-22-83

7. Sealed by: Name of Contractor: J. T. THOMAS DIAMOND DRILLING LTD

Name of Exploration Company CROWS NEST RESOURCES LTD

8. (a) Has any casing, drill pipe, drill bits, core barrel, etc. been left in the hole

(b) If so, give details and location: No materials left down hole

9. (a) Was the drillhole sealed in the manner outlined in the Chief Inspectors Instructions? Yes

(b) If no, give reasons and details of variation: \_\_\_\_\_

10. (a) Was the sealing effective? Yes

(b) Details of any tests carried out: \_\_\_\_\_

11. I certify that the above drillhole has been effectively sealed in accordance with the instructions of the Chief Inspector of Mines.

Signature: Robert Helle

Designation: FIELD COORDINATOR

Date: 07-31-83

Countersignature: Jim Belier

Designation: OPERATIONS MANAGER

Date: 08-02-83

239

Report on the Sealing of Drillholes

Inspection District # 9 Date of Report JULY 1 1983

Company CROWS NEST RESOURCES LTD Land District COAST #5

Coal Map Number 101 Licence Number L 391

1. Number of Drillhole 327 Bags of Cement 10

2. Surface elevation 794.1

3. Type (Vertical, diamond, rotary, size etc.) Vertical Diamond No

4. Drilled by: Name of Contractor: J. T. THOMAS DIAMOND DRILLING LTD

Name of Exploration Company CROWS NEST RESOURCES LTD

5. Date of Completion: 06-30-83

6. Date of Sealing: 06-30-83

7. Sealed by: Name of Contractor: J. T. THOMAS DIAMOND DRILLING LTD

Name of Exploration Company CROWS NEST RESOURCES LTD

8. (a) Has any casing, drill pipe, drill bits, core barrel, etc. been left in the hole

(b) If so, give details and location: No materials left down the hole

9. (a) Was the drillhole sealed in the manner outlined in the Chief Inspectors Instructions? Yes

(b) If no, give reasons and details of variation: \_\_\_\_\_

10. (a) Was the sealing effective? Yes

(b) Details of any tests carried out: \_\_\_\_\_

11. I certify that the above drillhole has been effectively sealed in accordance with the instructions of the Chief Inspector of Mines.

Signature: [Handwritten Signature]

Designation: Field Coordinator

Date: 07-01-83

Countersignature: [Handwritten Signature]

Designation: Operations Manager

Date: 07-04-83

**239**

Report on the Sealing of Drillholes

Inspection District #9 Date of Report JULY 31/83  
Company CROWS NEST RESOURCES LTD Land District COAST #5  
Coal Map Number 101 Licence Number CL 4271

1. Number of Drillhole 339 Bags of Cement 19

2. Surface elevation 720.6

3. Type (Vertical, diamond, rotary, size etc.) VERTICAL DIAMOND N/A

4. Drilled by: Name of Contractor: J.T. THOMAS DIAMOND DRILLING LTD  
Name of Exploration Company CROWS NEST RESOURCES LTD

5. Date of Completion: 07-23-83

6. Date of Sealing: 07-23-83

7. Sealed by: Name of Contractor: J.T. THOMAS DIAMOND DRILLING LTD  
Name of Exploration Company CROWS NEST RESOURCES LTD

8. (a) Has any casing, drill pipe, drill bits, core barrel, etc. been left in the hole?  
YES  
(b) If so, give details and location: PIEZOMETER INSTALLED  
SEE ATTACHED FOR DETAILS

9. (a) Was the drillhole sealed in the manner outlined in the Chief Inspectors Instructions? NO  
(b) If no, give reasons and details of variation: THIS HOLE IS BEING USED TO TEST AND MONITOR GROUND WATER

10. (a) Was the sealing effective? \_\_\_\_\_  
(b) Details of any tests carried out: \_\_\_\_\_

11. I certify that the above drillhole has been effectively sealed in accordance with the instructions of the Chief Inspector of Mines.

Signature: [Signature]

Designation: FIELD COORDINATOR

Date: 08-01-83

Countersignature: [Signature]

Designation: OPERATIONS MANAGER

Date: 08-02-83

**239**

First Piezometer Installation (Western) - Hole 359

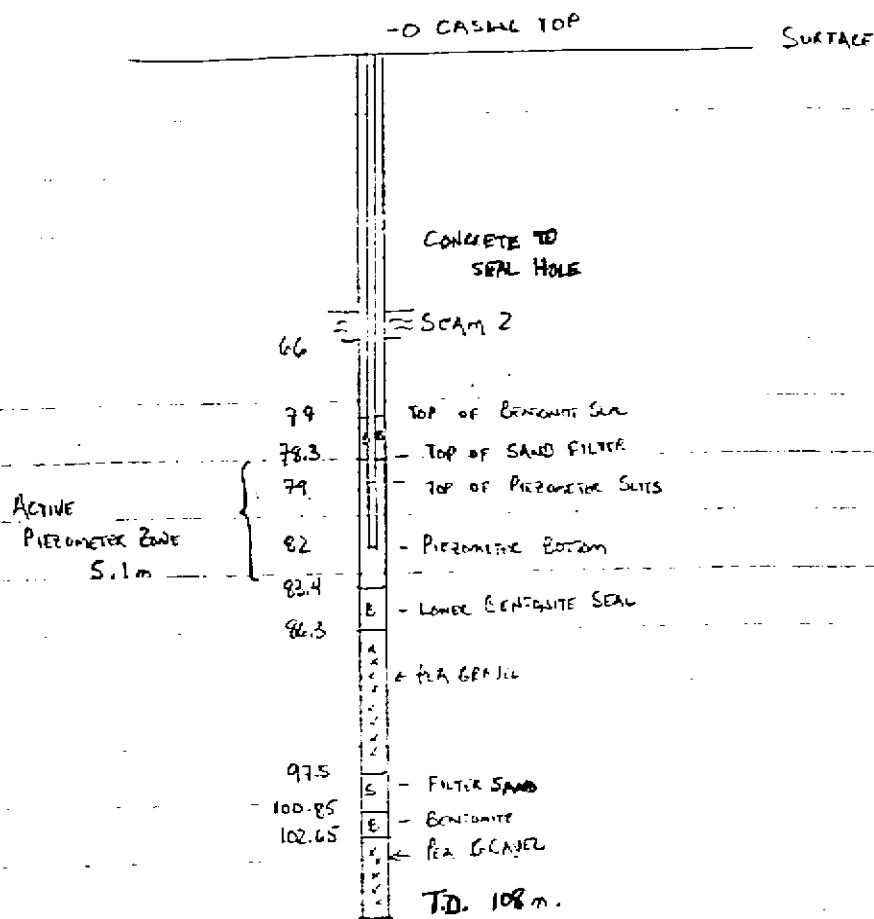

Notes:

1. Installation time:

- Preparation, calculations + materials assembly = 1 hour.
  - Installation from TD 108 m to 77 m (top bentonite seal) = 4 hours.
- total time = 5 hours.

2. The installation was very smooth due to the proper materials - sand and gravel and bentonite pellets - no problems encountered getting materials down the hole - no bridging.

Report on the Sealing of Drillholes

15- TELUKWA 83/3/A

Inspection District 49 Date of Report JULY 31 1983

Company CROWS NEST RESOURCES LTD Land District COAST #5

Coal Map Number 101 Licence Number CL 4271

1. Number of Drillhole 337 Bags of Cement 22

2. Surface elevation 733.3

3. Type (Vertical, diamond, rotary, size etc.) VERTICAL DIAMOND HQ

4. Drilled by: Name of Contractor: J. T. THOMAS DIAMOND DRILLING LTD

Name of Exploration Company CROWS NEST RESOURCES LTD

5. Date of Completion: 07-20-83

6. Date of Sealing: 07-20-83

7. Sealed by: Name of Contractor: J. T. THOMAS DIAMOND DRILLING LTD

Name of Exploration Company CROWS NEST RESOURCES LTD

8. (a) Has any casing, drill pipe, drill bits, core barrel, etc. been left in the hole?

(b) If so, give details and location: no materials left down hole

9. (a) Was the drillhole sealed in the manner outlined in the Chief Inspectors Instructions? Yes

(b) If no, give reasons and details of variation:

10. (a) Was the sealing effective? Yes

(b) Details of any tests carried out:

11. I certify that the above drillhole has been effectively sealed in accordance with the instructions of the Chief Inspector of Mines.

Signature: Robert A.ello

Designation: FIELD COORDINATOR

Date: 07-31-83

Countersignature: J. M. Brien

Designation: OPERATIONS MANAGER

Date: 08-02-83

239

Report on the Sealing of Drillholes

Inspection District #9 Date of Report AUGUST 22/83  
Company CROWS NEST RESOURCES LTD Land District COAST 45  
Coal Map Number 101 Licence Number CL 3709

1. Number of Drillhole 347 Bags of Cement 7  
2. Surface elevation 760.1  
3. Type (Vertical, diamond, rotary, size etc.) NQ

4. Drilled by: Name of Contractor: J. T. THOMAS DIAMOND DRILLING LTD  
Name of Exploration Company CROWS NEST RESOURCES LTD

5. Date of Completion: 08-02-83

6. Date of Sealing: 08-02-83

7. Sealed by: Name of Contractor: J. T. THOMAS DIAMOND DRILLING LTD  
Name of Exploration Company CROWS NEST RESOURCES LTD

8. (a) Has any casing, drill pipe, drill bits, core barrel, etc. been left in the ho  
(b) If so, give details and location: PIEZOMETER HOLE SEE  
ATTACHED FOR DETAILS

9. (a) Was the drillhole sealed in the manner outlined in the Chief Inspectors  
Instructions? No  
(b) If no, give reasons and details of variation: This hole is being  
used to monitor & test ground water

10. (a) Was the sealing effective?  
(b) Details of any tests carried out:

11. I certify that the above drillhole has been effectively sealed in accordance with  
the instructions of the Chief Inspector of Mines.

Signature: Robert Mello

Designation: FIELD COORDINATOR

Date: 08-22-83

Countersignature: Alan Baker

Designation: OPERATIONS MANAGER

Date: 08-22-83



Final Piezometer Installation - 004 347 - Seam 2.

West Gatham.

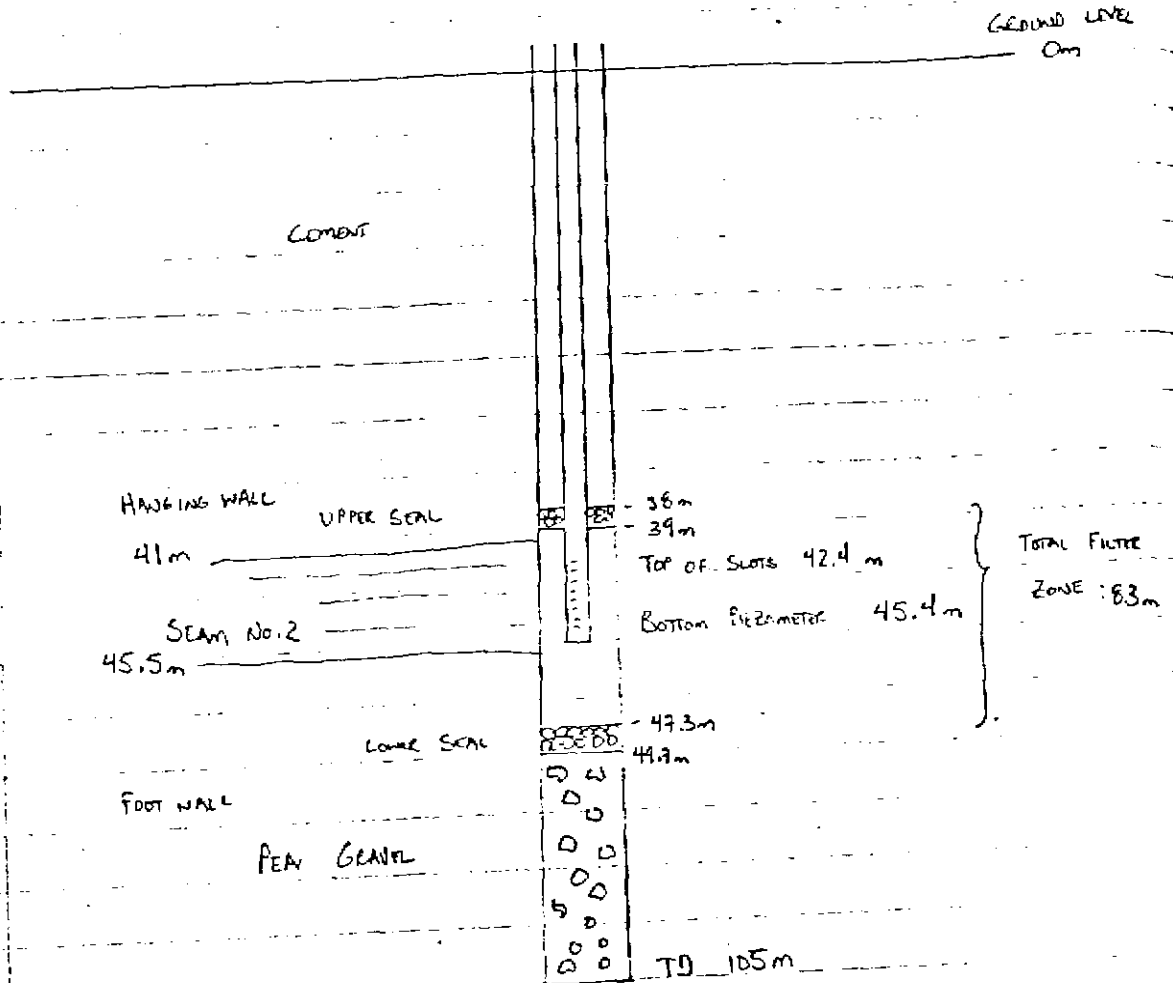

CREW: AL + DAVE HANDY

DRILLERS: DENNIS + JIM

INSTALLATION TIME: 3 1/2 HR.

Report on the Sealing of Drillholes

Inspection District #9 Date of Report August 22/83  
Company CROWS NEST RESOURCES LTD Land District COAST #5  
Coal Map Number 101 Licence Number L401

1. Number of Drillhole 348 Bags of Cement 20  
2. Surface elevation 731.1  
3. Type (Vertical, diamond, rotary, size etc.) VERTICAL DIAMOND NR  
4. Drilled by: Name of Contractor: J. T. THOMAS DIAMOND DRILLING LTD  
Name of Exploration Company CROWS NEST RESOURCES LTD

5. Date of Completion: 08-03-83

6. Date of Sealing: 08-03-83

7. Sealed by: Name of Contractor: J. T. THOMAS DIAMOND DRILLING LTD  
Name of Exploration Company CROWS NEST RESOURCES LTD

8. (a) Has any casing, drill pipe, drill bits, core barrel, etc. been left in the hole?  
(b) If so, give details and location: No materials left down hole

9. (a) Was the drillhole sealed in the manner outlined in the Chief Inspectors Instructions? Yes  
(b) If no, give reasons and details of variation:

10. (a) Was the sealing effective? Yes  
(b) Details of any tests carried out:

11. I certify that the above drillhole has been effectively sealed in accordance with the instructions of the Chief Inspector of Mines.

Signature: Robert P. Hutto  
Designation: FIELD COORDINATOR  
Date: 08-22-83  
Countersignature: Len Baker  
Designation: OPERATIONS MANAGER  
Date: 08-22-83

239



Report on the Sealing of Drillholes

Inspection District #9 Date of Report August 22/83  
Company CROWS NEST RESOURCES LTD Land District CONST #5  
Coal Map Number 101 Licence Number L 401

1. Number of Drillhole 349 Bags of Cement 20  
2. Surface elevation 717.4  
3. Type (Vertical, diamond, rotary, size etc.) VERTICAL DIAMOND NR  
4. Drilled by: Name of Contractor: J. T. THOMAS DIAMOND DRILLING LTD  
Name of Exploration Company CROWS NEST RESOURCES LTD

5. Date of Completion: 08-04-83

6. Date of Sealing: 08-04-83

7. Sealed by: Name of Contractor: J. T. THOMAS DIAMOND DRILLING LTD  
Name of Exploration Company CROWS NEST RESOURCES LTD

8. (a) Has any casing, drill pipe, drill bits, core barrel, etc. been left in the hole?  
(b) If so, give details and location: 1- NW CASING SHOE AT 18 m

9. (a) Was the drillhole sealed in the manner outlined in the Chief Inspectors Instructions? Yes

(b) If no, give reasons and details of variation:

10. (a) Was the sealing effective? yes

(b) Details of any tests carried out:

11. I certify that the above drillhole has been effectively sealed in accordance with the instructions of the Chief Inspector of Mines.

Signature: Robert Avello

Designation: FIELD COORDINATOR

Date: 08-22-83

Countersignature: [Signature]

Designation: OPERATIONS MANAGER

Date: 08-22-83

259

Report on the Sealing of Drillholes

Inspection District #9 Date of Report AUGUST 22 1983  
Company CROWS NEST RESOURCES LTD Land District COAST #5  
Coal Map Number 101 Licence Number L 401

1. Number of Drillhole 350 Bags of Cement -  
2. Surface elevation 715.1  
3. Type (Vertical, diamond, rotary, size etc.) VERTICAL DIAMOND NO  
4. Drilled by: Name of Contractor: J. T. THOMAS DIAMOND DRILLING LTD  
Name of Exploration Company CROWS NEST RESOURCES LTD

5. Date of Completion: 08-14-83

6. Date of Sealing:

7. Sealed by: Name of Contractor: J. T. THOMAS DIAMOND DRILLING LTD  
Name of Exploration Company CROWS NEST RESOURCES LTD

8. (a) Has any casing, drill pipe, drill bits, core barrel, etc. been left in the hole?  
(b) If so, give details and location: No materials left in hole

9. (a) Was the drillhole sealed in the manner outlined in the Chief Inspectors Instructions? No  
(b) If no, give reasons and details of variation: This hole was shut down in bedrock at a depth of 62.5 meters No coal was intersected in this hole

10. (a) Was the sealing effective?  
(b) Details of any tests carried out:

11. I certify that the above drillhole has been effectively sealed in accordance with the instructions of the Chief Inspector of Mines.

Signature: Robert Aretto

Designation: FIELD COORDINATOR

Date: 08-22-83

Countersignature: Len Bell

Designation: Operations Manager

Date: 08-22-83



Report on the Sealing of Drillholes

Inspection District # 9 Date of Report AUGUST 22/83  
Company CROWS NEST RESOURCES LTD Land District CONST #5  
Coal Map Number 101 Licence Number L 401

1. Number of Drillhole 351 Bags of Cement 20  
2. Surface elevation 721.4  
3. Type (Vertical, diamond, rotary, size etc.) VERTICAL DIAMOND NR  
4. Drilled by: Name of Contractor: J. T. THOMAS DIAMOND DRILLING LTD  
Name of Exploration Company CROWS NEST RESOURCES LTD

5. Date of Completion: 08-14-83

6. Date of Sealing: 08-15-83

7. Sealed by: Name of Contractor: J. T. THOMAS DIAMOND DRILLING LTD  
Name of Exploration Company CROWS NEST RESOURCES LTD

8. (a) Has any casing, drill pipe, drill bits, core barrel, etc. been left in the hole  
(b) If so, give details and location: No materials left down the hole

9. (a) Was the drillhole sealed in the manner outlined in the Chief Inspectors Instructions? Yes

(b) If no, give reasons and details of variation: \_\_\_\_\_  
\_\_\_\_\_  
\_\_\_\_\_

10. (a) Was the sealing effective? Yes  
(b) Details of any tests carried out: \_\_\_\_\_  
\_\_\_\_\_

11. I certify that the above drillhole has been effectively sealed in accordance with the instructions of the Chief Inspector of Mines.

Signature: Robert P. Helt

Designation: FIELD COORDINATOR

Date: 08-22-83

Countersignature: Lu. Blun

Designation: OPERATIONS MANAGER

Date: 08-22-83

**239**

Report on the Sealing of Drillholes

TK-TELKWA 83(3)A

Inspection District #9 Date of Report AUGUST 22/83

Company CROWS NEST RESOURCES LTD Land District COAST #5

Coal Map Number 101 Licence Number CL 3876

1. Number of Drillhole 352 Bags of Cement 25

2. Surface elevation 762.0

3. Type (Vertical, diamond, rotary, size etc.) VERTICAL DIAMOND NR

4. Drilled by: Name of Contractor: J.T. THOMAS DIAMOND DRILLING LTD  
Name of Exploration Company CROWS NEST RESOURCES LTD

5. Date of Completion: 08-17-83

6. Date of Sealing: 08-17-83

7. Sealed by: Name of Contractor: J.T. THOMAS DIAMOND DRILLING LTD  
Name of Exploration Company CROWS NEST RESOURCES LTD

8. (a) Has any casing, drill pipe, drill bits, core barrel, etc. been left in the hole?  
(b) If so, give details and location: No materials left in hole

9. (a) Was the drillhole sealed in the manner outlined in the Chief Inspectors Instructions? Yes

(b) If no, give reasons and details of variation:

10. (a) Was the sealing effective? Yes

(b) Details of any tests carried out:

11. I certify that the above drillhole has been effectively sealed in accordance with the instructions of the Chief Inspector of Mines.

Signature: Robert Helle

Designation: FIELD COORDINATOR

Date: 08-22-83

Countersignature: Jim Siler

Designation: OPERATIONS MANAGER

Date: 08-22-83



Inspection District # 9 Date of Report AUGUST 22/83  
Company CROWS NEST RESOURCES LTD Land District COAST # 5  
Coal Map Number 101 Licence Number L 401

1. Number of Drillhole 353 Bags of Cement 20

2. Surface elevation 720.3

3. Type (Vertical, diamond, rotary, size etc.) VERTICAL DIAMOND NA

4. Drilled by: Name of Contractor: J. T. THOMAS DIAMOND DRILLING LTD  
Name of Exploration Company CROWS NEST RESOURCES LTD

5. Date of Completion: 08-18-83

6. Date of Sealing: 08-18-83

7. Sealed by: Name of Contractor: J. T. THOMAS DIAMOND DRILLING LTD  
Name of Exploration Company CROWS NEST RESOURCES LTD

8. (a) Has any casing, drill pipe, drill bits, core barrel, etc. been left in the hole?

(b) If so, give details and location: 70.1 meters of NA drill rod left on bottom

9. (a) Was the drillhole sealed in the manner outlined in the Chief Inspectors Instructions? Yes

(b) If no, give reasons and details of variation: \_\_\_\_\_

10. (a) Was the sealing effective? Yes

(b) Details of any tests carried out: \_\_\_\_\_

11. I certify that the above drillhole has been effectively sealed in accordance with the instructions of the Chief Inspector of Mines.

Signature: [Signature]

Designation: FIELD COORDINATOR

Date: 08-22-83

Countersignature: [Signature]

Designation: OPERATIONS MANAGER

Date: 08-22-83

**237**

Inspection District #9 Date of Report Dec 9/83

Company CROWS NEST RESOURCES LTD Land District COAST #5

Coal Map Number 101 Licence Number 4271

1. Number of Drillhole 354 Bags of Cement 26

2. Surface elevation 660.9

3. Type (Vertical, diamond, rotary, size etc.) VERTICAL DIAMOND NO

4. Drilled by: Name of Contractor: J.T. THOMAS DIAMOND DRILLING LTD

Name of Exploration Company CROWS NEST RESOURCES LTD

5. Date of Completion: Dec 7/83

6. Date of Sealing: Dec 8/83

7. Sealed by: Name of Contractor: J.T. THOMAS DIAMOND DRILLING LTD

Name of Exploration Company CROWS NEST RESOURCES LTD

8. (a) Has any casing, drill pipe, drill bits, core barrel, etc. been left in the hole?  
No.

(b) If so, give details and location: \_\_\_\_\_

\_\_\_\_\_

9. (a) Was the drillhole sealed in the manner outlined in the Chief Inspectors Instructions? Yes

(b) If no, give reasons and details of variation: \_\_\_\_\_

\_\_\_\_\_

10. (a) Was the sealing effective? Yes

(b) Details of any tests carried out: \_\_\_\_\_

\_\_\_\_\_

11. I certify that the above drillhole has been effectively sealed in accordance with the instructions of the Chief Inspector of Mines.

Signature: [Signature]

Designation: FIELD COORDINATOR

Date: Dec 9/83

Countersignature: [Signature]

Designation: OPERATIONS MANAGER

Date: Dec 9/83

**239**

Report on the Sealing of Drillholes

TK-TELKWA 83(3)A

Inspection District #9 Date of Report Dec 10/83

Company CROWS NEST RESOURCES LTD Land District COAST #5

Coal Map Number 101 Licence Number 4271

1. Number of Drillhole 355 Bags of Cement 18

2. Surface elevation 685.7

3. Type (Vertical, diamond, rotary, size etc.) VERTICAL DIAMOND N/A

4. Drilled by: Name of Contractor: J.T. THOMAS DIAMOND DRILLING LTD

Name of Exploration Company CROWS NEST RESOURCES LTD

5. Date of Completion: Dec 9/83

6. Date of Sealing: Dec 9/83

7. Sealed by: Name of Contractor: J.T. THOMAS DIAMOND DRILLING LTD

Name of Exploration Company CROWS NEST RESOURCES LTD

8. (a) Has any casing, drill pipe, drill bits, core barrel, etc. been left in the hole? No.

(b) If so, give details and location: \_\_\_\_\_

9. (a) Was the drillhole sealed in the manner outlined in the Chief Inspectors Instructions? Yes

(b) If no, give reasons and details of variation: \_\_\_\_\_

10. (a) Was the sealing effective? Yes

(b) Details of any tests carried out: \_\_\_\_\_

11. I certify that the above drillhole has been effectively sealed in accordance with the instructions of the Chief Inspector of Mines.

Signature: [Handwritten Signature]

Designation: FIELD COORDINATOR

Date: Dec 10/83

Countersignature: [Handwritten Signature]

Designation: OPERATIONS MANAGER

Date: Dec 12/83

**237**

Report on the Sealing of Drillholes

1K-TEUKWA 83631A

Inspection District #9 Date of Report Dec 10/83

Company CROWS NEST RESOURCES LTD Land District COAST #5

Coal Map Number 101 Licence Number 4271

1. Number of Drillhole 356 Bags of Cement 21

2. Surface elevation 670.4

3. Type (Vertical, diamond, rotary, size etc.) VERTICAL DIAMOND N.G

4. Drilled by: Name of Contractor: J.T. THOMAS DIAMOND DRILLING LTD

Name of Exploration Company CROWS NEST RESOURCES LTD

5. Date of Completion: Dec 9/83

6. Date of Sealing: Dec 9/83

7. Sealed by: Name of Contractor: J.T. THOMAS DIAMOND DRILLING LTD

Name of Exploration Company CROWS NEST RESOURCES LTD

8. (a) Has any casing, drill pipe, drill bits, core barrel, etc. been left in the hole? No.

(b) If so, give details and location: \_\_\_\_\_

\_\_\_\_\_

\_\_\_\_\_

9. (a) Was the drillhole sealed in the manner outlined in the Chief Inspectors Instructions? yes

(b) If no, give reasons and details of variation: \_\_\_\_\_

\_\_\_\_\_

\_\_\_\_\_

10. (a) Was the sealing effective? yes

(b) Details of any tests carried out: \_\_\_\_\_

\_\_\_\_\_

11. I certify that the above drillhole has been effectively sealed in accordance with the instructions of the Chief Inspector of Mines.

Signature Robert Muthu

Designation: FIELD COORDINATOR

Date: December 10/83

Countersignature: [Signature]

Designation: OPERATIONS MANAGER

Date: Dec 12/83

239



Report on the Sealing of Drillholes

TK - TELKWA 83(3)A

Inspection District #9 Date of Report Dec 11/83

Company CROWS NEST RESOURCES LTD Land District COAST #5

Coal Map Number 101 Licence Number 4271

1. Number of Drillhole 357 Bags of Cement 16

2. Surface elevation 686.8

3. Type (Vertical, diamond, rotary, size etc.) VERTICAL DIAMOND NA

4. Drilled by: Name of Contractor: J.T. THOMAS DIAMOND DRILLING LTD

Name of Exploration Company CROWS NEST RESOURCES LTD

5. Date of Completion: Dec 10/83

6. Date of Sealing: Dec 10/83

7. Sealed by: Name of Contractor: J.T. THOMAS DIAMOND DRILLING LTD

Name of Exploration Company CROWS NEST RESOURCES LTD

8. (a) Has any casing, drill pipe, drill bits, core barrel, etc. been left in the hole? No.

(b) If so, give details and location: \_\_\_\_\_

\_\_\_\_\_

9. (a) Was the drillhole sealed in the manner outlined in the Chief Inspectors Instructions? Yes

(b) If no, give reasons and details of variation: \_\_\_\_\_

\_\_\_\_\_

10. (a) Was the sealing effective? Yes

(b) Details of any tests carried out: \_\_\_\_\_

\_\_\_\_\_

11. I certify that the above drillhole has been effectively sealed in accordance with the instructions of the Chief Inspector of Mines.

Signature: Robert A. [Signature]

Designation: FIELD COORDINATOR

Date: Dec. 11/83

Countersignature: [Signature]

Designation: OPERATIONS MANAGER

Date: DEC 12/83

**237**

Report on the Sealing of Drillholes

TK-TELKWA 83(3)A

Inspection District #9 Date of Report Dec 12, 83

Company CROWS NEST RESOURCES LTD Land District COAST #5

Coal Map Number 101 Licence Number 4271

1. Number of Drillhole 358 Bags of Cement 18

2. Surface elevation 684.8

3. Type (Vertical, diamond, rotary, size etc.) VERTICAL DIAMOND N.G.

4. Drilled by: Name of Contractor: J.T. THOMAS DIAMOND DRILLING LTD  
Name of Exploration Company CROWS NEST RESOURCES LTD

5. Date of Completion: Dec 10 /83

6. Date of Sealing: Dec 11 /83

7. Sealed by: Name of Contractor: J.T. THOMAS DIAMOND DRILLING LTD  
Name of Exploration Company CROWS NEST RESOURCES LTD

8. (a) Has any casing, drill pipe, drill bits, core barrel, etc. been left in the hole?  
(b) <sup>No</sup> If so, give details and location: \_\_\_\_\_

9. (a) Was the drillhole sealed in the manner outlined in the Chief Inspectors Instructions? Yes

(b) If no, give reasons and details of variation: \_\_\_\_\_

10. (a) Was the sealing effective? Yes

(b) Details of any tests carried out: \_\_\_\_\_

11. I certify that the above drillhole has been effectively sealed in accordance with the instructions of the Chief Inspector of Mines.

Signature: [Signature]

Designation: FIELD COORDINATOR

Date: Dec 13 /83

Countersignature: [Signature]

Designation: OPERATIONS MANAGER

Date: Dec 13 /83

**239**

Report on the Sealing of Drillholes

TK - TELKWA 83/310

Inspection District #9 Date of Report December 15/83

Company CROWS NEST RESOURCES LTD Land District COAST #5

Coal Map Number 101 Licence Number 4271

1. Number of Drillhole 359 Bags of Cement 23

2. Surface elevation 694.4

3. Type (Vertical, diamond, rotary, size etc.) VERTICAL DIAMOND NA

4. Drilled by: Name of Contractor: J.T. THOMAS DIAMOND DRILLING LTD

Name of Exploration Company CROWS NEST RESOURCES LTD

5. Date of Completion: Dec 12/83

6. Date of Sealing: Dec 12/83

7. Sealed by: Name of Contractor: J.T. THOMAS DIAMOND DRILLING LTD

Name of Exploration Company CROWS NEST RESOURCES LTD

8. (a) Has any casing, drill pipe, drill bits, core barrel, etc. been left in the hole?  
No.

(b) If so, give details and location: \_\_\_\_\_

\_\_\_\_\_

\_\_\_\_\_

9. (a) Was the drillhole sealed in the manner outlined in the Chief Inspectors Instructions? YES

(b) If no, give reasons and details of variation: \_\_\_\_\_

\_\_\_\_\_

\_\_\_\_\_

10. (a) Was the sealing effective? YES

(b) Details of any tests carried out: \_\_\_\_\_

\_\_\_\_\_

11. I certify that the above drillhole has been effectively sealed in accordance with the instructions of the Chief Inspector of Mines.

Signature: Robert A. Heth

Designation: FIELD COORDINATOR

Date: Dec 13/83

Countersignature: Jim R. ...

Designation: OPERATIONS MANAGER

Date: Dec 13/83

**237**

Report on the Sealing of Drillholes

TK - TELKWA 83631A

Inspection District #9 Date of Report Dec 14 / 83

Company CROWS NEST RESOURCES LTD Land District COAST #5

Coal Map Number 101 Licence Number 4271

1. Number of Drillhole 360 Bags of Cement 27

2. Surface elevation 722.3

3. Type (Vertical, diamond, rotary, size etc.) VERTICAL DIAMOND NA

4. Drilled by: Name of Contractor: J.T. THOMAS DIAMOND DRILLING LTD  
Name of Exploration Company CROWS NEST RESOURCES LTD

5. Date of Completion: Dec 12 / 83

6. Date of Sealing: Dec 13 / 83

7. Sealed by: Name of Contractor: J.T. THOMAS DIAMOND DRILLING LTD  
Name of Exploration Company CROWS NEST RESOURCES LTD

8. (a) Has any casing, drill pipe, drill bits, core barrel, etc. been left in the hole?  
No.

(b) If so, give details and location: \_\_\_\_\_

\_\_\_\_\_

9. (a) Was the drillhole sealed in the manner outlined in the Chief Inspectors Instructions? yes

(b) If no, give reasons and details of variation: \_\_\_\_\_

\_\_\_\_\_

10. (a) Was the sealing effective? yes

(b) Details of any tests carried out: \_\_\_\_\_

\_\_\_\_\_

11. I certify that the above drillhole has been effectively sealed in accordance with the instructions of the Chief Inspector of Mines.

Signature: Robert Anello

Designation: FIELD COORDINATOR

Date: Dec 14 / 83

Countersignature: Lin Babin

Designation: OPERATIONS MANAGER

Date: Dec 14 / 83



Report on the Sealing of Drillholes

15 - FELKWA 83(3)A

Inspection District #9 Date of Report Dec 14 1983

Company CROWS NEST RESOURCES LTD Land District COAST #5

Coal Map Number 101 Licence Number 4271

1. Number of Drillhole 361 Bags of Cement 15

2. Surface elevation 684.5

3. Type (Vertical, diamond, rotary, size etc.) VERTICAL DIAMOND N.G.

4. Drilled by: Name of Contractor: J.T. THOMAS DIAMOND DRILLING LTD  
Name of Exploration Company CROWS NEST RESOURCES LTD

5. Date of Completion: December 13, 1983

6. Date of Sealing: December 13, 1983

7. Sealed by: Name of Contractor: J.T. THOMAS DIAMOND DRILLING LTD  
Name of Exploration Company CROWS NEST RESOURCES LTD

8. (a) Has any casing, drill pipe, drill bits, core barrel, etc. been left in the hole?  
No  
(b) If so, give details and location: \_\_\_\_\_

9. (a) Was the drillhole sealed in the manner outlined in the Chief Inspectors Instructions? Yes

(b) If no, give reasons and details of variation: \_\_\_\_\_

10. (a) Was the sealing effective? yes

(b) Details of any tests carried out: \_\_\_\_\_

11. I certify that the above drillhole has been effectively sealed in accordance with the instructions of the Chief Inspector of Mines.

Signature: [Signature]

Designation: FIELD COORDINATOR

Date: 83-14-12

Countersignature: [Signature]

Designation: OPERATIONS MANAGER

Date: 83-14-12

239

Report on the Sealing of Drillholes

1K-TELKWA 83(3)A

Inspection District #9 Date of Report Dec 15/83

Company CROWS NEST RESOURCES LTD Land District COAST #5

Coal Map Number 101 Licence Number 4271

1. Number of Drillhole 362 Bags of Cement 30

2. Surface elevation 740.9

3. Type (Vertical, diamond, rotary, size etc.) VERTICAL DIAMOND NA

4. Drilled by: Name of Contractor: J.T. THOMAS DIAMOND DRILLING LTD

Name of Exploration Company CROWS NEST RESOURCES LTD

5. Date of Completion: Dec 14/83

6. Date of Sealing: Dec 14/83

7. Sealed by: Name of Contractor: J.T. THOMAS DIAMOND DRILLING LTD

Name of Exploration Company CROWS NEST RESOURCES LTD

8. (a) Has any casing, drill pipe, drill bits, core barrel, etc. been left in the hole? No.

(b) If so, give details and location: \_\_\_\_\_

\_\_\_\_\_

\_\_\_\_\_

9. (a) Was the drillhole sealed in the manner outlined in the Chief Inspectors Instructions? Yes

(b) If no, give reasons and details of variation: \_\_\_\_\_

\_\_\_\_\_

\_\_\_\_\_

10. (a) Was the sealing effective? Yes

(b) Details of any tests carried out: \_\_\_\_\_

\_\_\_\_\_

11. I certify that the above drillhole has been effectively sealed in accordance with the instructions of the Chief Inspector of Mines.

Signature: Robert P. ...

Designation: FIELD COORDINATOR

Date: Dec 15/83

Countersignature: [Signature]

Designation: OPERATIONS MANAGER

Date: Dec 15/83

239

Report on the Sealing of Drillholes

TELKWA 83/31A

Inspection District #9 Date of Report December 16, 1983

Company CROWS NEST RESOURCES LTD Land District COAST #5

Coal Map Number 101 Licence Number 4271

1. Number of Drillhole 364 Bags of Cement 15

2. Surface elevation 692.5

3. Type (Vertical, diamond, rotary, size etc.) VERTICAL DIAMOND NA

4. Drilled by: Name of Contractor: J.T. THOMAS DIAMOND DRILLING LTD

Name of Exploration Company CROWS NEST RESOURCES LTD

5. Date of Completion: Dec 15, 1983

6. Date of Sealing: Dec 15, 1983

7. Sealed by: Name of Contractor: J.T. THOMAS DIAMOND DRILLING LTD

Name of Exploration Company CROWS NEST RESOURCES LTD

8. (a) Has any casing, drill pipe, drill bits, core barrel, etc. been left in the hole? No.

(b) If so, give details and location: \_\_\_\_\_

\_\_\_\_\_  
\_\_\_\_\_

9. (a) Was the drillhole sealed in the manner outlined in the Chief Inspectors Instructions? Yes

(b) If no, give reasons and details of variation: \_\_\_\_\_

\_\_\_\_\_  
\_\_\_\_\_

10. (a) Was the sealing effective? Yes

(b) Details of any tests carried out: \_\_\_\_\_

\_\_\_\_\_

11. I certify that the above drillhole has been effectively sealed in accordance with the instructions of the Chief Inspector of Mines.

Signature: Robert Hutto

Designation: FIELD COORDINATOR

Date: December 16 1983

Countersignature: Len Brown

Designation: OPERATIONS MANAGER

Date: December 16 1983

239

Report on the Sealing of Drillholes

TK - TELKWA 83(3)A

Inspection District #9 Date of Report DEC 17/83

Company CROWS NEST RESOURCES LTD Land District COAST #5

Coal Map Number 101 Licence Number 4271

1. Number of Drillhole 365 Bags of Cement 26

2. Surface elevation 749.4

3. Type (Vertical, diamond, rotary, size etc.) VERTICAL DIAMOND N.G

4. Drilled by: Name of Contractor: J.T. THOMAS DIAMOND DRILLING LTD

Name of Exploration Company CROWS NEST RESOURCES LTD

5. Date of Completion: Dec 16/83

6. Date of Sealing: Dec 16/83

7. Sealed by: Name of Contractor: J.T. THOMAS DIAMOND DRILLING LTD

Name of Exploration Company CROWS NEST RESOURCES LTD

8. (a) Has any casing, drill pipe, drill bits, core barrel, etc. been left in the hole?

(b) <sup>No</sup> If so, give details and location: \_\_\_\_\_

\_\_\_\_\_  
\_\_\_\_\_

9. (a) Was the drillhole sealed in the manner outlined in the Chief Inspectors Instructions? Yes

(b) If no, give reasons and details of variation: \_\_\_\_\_

\_\_\_\_\_  
\_\_\_\_\_

10. (a) Was the sealing effective? Yes

(b) Details of any tests carried out: \_\_\_\_\_

\_\_\_\_\_

11. I certify that the above drillhole has been effectively sealed in accordance with the instructions of the Chief Inspector of Mines.

Signature: Robert Hunter

Designation: FIELD COORDINATOR

Date: Dec 19/83

Countersignature: [Signature]

Designation: OPERATIONS MANAGER

Date: Dec 19/83

**239**



Report on the Sealing of Drillholes

11C- TELUKWA 83 (3)A

Inspection District #9 Date of Report December 17/83

Company CROWS NEST RESOURCES LTD Land District COAST #5

Coal Map Number 101 Licence Number 4271

1. Number of Drillhole 366 Bags of Cement 25

2. Surface elevation 686.0

3. Type (Vertical, diamond, rotary, size etc.) VERTICAL DIAMOND N/A

4. Drilled by: Name of Contractor: J.T. THOMAS DIAMOND DRILLING LTD

Name of Exploration Company CROWS NEST RESOURCES LTD

5. Date of Completion: Dec 16, 1983

6. Date of Sealing: Dec 16, 1983

7. Sealed by: Name of Contractor: J.T. THOMAS DIAMOND DRILLING LTD

Name of Exploration Company CROWS NEST RESOURCES LTD

8. (a) Has any casing, drill pipe, drill bits, core barrel, etc. been left in the hole? No. (b) If so, give details and location:

\_\_\_\_\_

\_\_\_\_\_

\_\_\_\_\_

9. (a) Was the drillhole sealed in the manner outlined in the Chief Inspectors Instructions? Yes

(b) If no, give reasons and details of variation: \_\_\_\_\_

\_\_\_\_\_

\_\_\_\_\_

10. (a) Was the sealing effective? Yes

(b) Details of any tests carried out: \_\_\_\_\_

\_\_\_\_\_

11. I certify that the above drillhole has been effectively sealed in accordance with the instructions of the Chief Inspector of Mines.

Signature: Robert H. ...

Designation: FIELD COORDINATOR

Date: December 17 1983

Countersignature: ...

Designation: OPERATIONS MANAGER

Date: December 19 1983

239

Report on the Sealing of Drillholes

TK - TELKWA 83(3)A

Inspection District 49 Date of Report DEC 18 / 83

Company CROWS NEST RESOURCES LTD Land District COAST #5

Coal Map Number 101 Licence Number 4271

1. Number of Drillhole 367 Bags of Cement 21

2. Surface elevation 752.8

3. Type (Vertical, diamond, rotary, size etc.) VERTICAL DIAMOND N/A

4. Drilled by: Name of Contractor: J.T. THOMAS DIAMOND DRILLING LTD

Name of Exploration Company CROWS NEST RESOURCES LTD

5. Date of Completion: Dec 17-83

6. Date of Sealing: DEC 17-83

7. Sealed by: Name of Contractor: J.T. THOMAS DIAMOND DRILLING LTD

Name of Exploration Company CROWS NEST RESOURCES LTD

8. (a) Has any casing, drill pipe, drill bits, core barrel, etc. been left in the hole?

(b) If so, give details and location: \_\_\_\_\_

\_\_\_\_\_  
\_\_\_\_\_  
\_\_\_\_\_

9. (a) Was the drillhole sealed in the manner outlined in the Chief Inspectors Instructions? YES

(b) If no, give reasons and details of variation: \_\_\_\_\_

\_\_\_\_\_  
\_\_\_\_\_  
\_\_\_\_\_

10. (a) Was the sealing effective? YES

(b) Details of any tests carried out: \_\_\_\_\_

\_\_\_\_\_  
\_\_\_\_\_

11. I certify that the above drillhole has been effectively sealed in accordance with the instructions of the Chief Inspector of Mines.

Signature: Robert A. Hallett

Designation: FIELD COORDINATOR

Date: DEC 20/83

Countersignature: [Signature]

Designation: OPERATIONS MANAGER

Date: DEC 19/83

**239**

Report on the Sealing of Drillholes

TK - TELKWA 83/3/A

Inspection District #9 Date of Report December 18/83

Company CROWS NEST RESOURCES LTD Land District COAST #5

Coal Map Number 101 Licence Number 4271

1. Number of Drillhole 368 Bags of Cement 20

2. Surface elevation 690.0

3. Type (Vertical, diamond, rotary, size etc.) VERTICAL DIAMOND N/A

4. Drilled by: Name of Contractor: J.T. THOMAS DIAMOND DRILLING LTD

Name of Exploration Company CROWS NEST RESOURCES LTD

5. Date of Completion: Dec 17, 1983

6. Date of Sealing: Dec 17, 1983

7. Sealed by: Name of Contractor: J.T. THOMAS DIAMOND DRILLING LTD

Name of Exploration Company CROWS NEST RESOURCES LTD

8. (a) Has any casing, drill pipe, drill bits, core barrel, etc. been left in the hole?  
No.  
(b) If so, give details and location: \_\_\_\_\_

9. (a) Was the drillhole sealed in the manner outlined in the Chief Inspectors Instructions? Yes

(b) If no, give reasons and details of variation: \_\_\_\_\_

10. (a) Was the sealing effective? Yes

(b) Details of any tests carried out: \_\_\_\_\_

11. I certify that the above drillhole has been effectively sealed in accordance with the instructions of the Chief Inspector of Mines.

Signature: [Signature]

Designation: FIELD COORDINATOR

Date: December 18/83

Countersignature: [Signature]

Designation: OPERATIONS MANAGER

Date: December 19/83

239