

HAT CREEK PROJECT

MINING REPORT - VOLUME I

DECEMBER 1979

ERRATA

- Page 1-1 1st. para. Should be "... 500 MW (net) unit..."
2nd. para. Should be "... 2000 MW (net) powerplant."
Should be "... 4 x 500 MW (net) ..."
- Page 2-4 Item (9) Should read "... equivalent to 6.19 mills/kW.h
at a capacity factor of 65%.
- Page 3-1 2nd. para. Should be "... create some 875 steady jobs at
the mine ..."
- Page 3-6 1st. para. Should be "... circumference of around 8 km ..."
- Page 4-15 Section 4.6.3.1 Should be "... to be 739 million tonnes ..."
Section 4.6.3.2 Should be "... 746 million tonnes ..."
- Page 4-35 Figure 4-5 Note that expressions for X and Y based on Heating
Value in kJ/kg; graph is based on Heating Value
of MJ/kg.
- Page 5-31 Section 4 Add this paragraph:- Maximum gradients used for
the mine roads are: (1) Haul roads 8% (2) Service
roads - 10%.
- Page 5-42 Section 5.5.3.2 In the last sentence of the first paragraph it should
read "... not closer than 23 m to the crest ..."
- Page 5-44 Section (3) Second and third sentences should read "... 305
million bank m³ ..." and "... 134 million bank m³
..." respectively.

Page 5-45 3rd. para.

Last sentence should read "... 29 million bank m³ ..."

Table 5-8

The cumulative column under the TOTAL section should read:

Total

Cum.

9.37

30.99

75.78

125.90

142.08

B.C. HYDRO AND POWER AUTHORITY
Mining Department — Thermal Division



HAT CREEK PROJECT

| | | |
|--|--|--|
| MINISTRY OF ENERGY, MINES AND PETROLEUM RESOURCES | | |
| AUG 19 1981 | | |
| Rec'd | | |
| | | |
| | | |

MINING REPORT —
Volume 1 (of 2)

DECEMBER, 1979.

| |
|----------|
| Copy No. |
| 31 |



**Excavating Trench 'A'
by Hydraulic Shovel**

1977 Bulk Sample Program

HAT CREEK PROJECT

VOLUME 1

TABLE OF CONTENTS

Page

| | | |
|-----|--|------|
| 1 | <u>INTRODUCTION</u> | 1-1 |
| 2 | <u>SUMMARY</u> | |
| 2.1 | Mining Studies Performed - April 1974 to December 1978 | 2-1 |
| 2.2 | 1979 Studies | 2-3 |
| 2.3 | Consultants Employed | 2-5 |
| 3 | <u>A PROJECT DESCRIPTION</u> | |
| 3.1 | The Plan | 3-1 |
| 3.2 | A History of the Project | 3-2 |
| 3.3 | The Location of Mine and Powerplant | 3-3 |
| 3.4 | The Resource: Coal | 3-4 |
| 3.5 | The Project | 3-5 |
| 3.6 | The Mining Method | 3-6 |
| 3.7 | The Powerplant | 3-8 |
| 3.8 | Powerplant Emissions and Waste | 3-9 |
| 3.9 | Two Key Areas: Drainage and Reclamation | 3-10 |

| | <u>Page</u> |
|--|-------------|
| 4 <u>GEOLOGY</u> | |
| 4.1 Introduction | 4-1 |
| 4.2 Exploration and Development | 4-2 |
| 4.2.1 Geophysical and Geological Logging | 4-3 |
| 4.2.2 Coal Sampling | 4-3 |
| 4.3 Geology | 4-4 |
| 4.3.1 Stratigraphy | 4-4 |
| 4.3.2 Structure | 4-4 |
| 4.3.3 Burn Zone | 4-5 |
| 4.3.4 Trench Geology | 4-5 |
| 4.4 Depositional Environment | 4-7 |
| 4.5 Coal Quality | 4-8 |
| 4.5.1 Ash and Heating Value | 4-8 |
| 4.5.2 Moisture Determination | 4-9 |
| 4.5.3 Sulphur Distribution | 4-10 |
| 4.5.4 Mineral Analysis of Ash, Ash Fusibility, and Grindability | 4-11 |
| 4.5.5 Specific Gravity | 4-11 |
| 4.6 Coal Reserves | 4-13 |
| 4.6.1 Introduction | 4-13 |
| 4.6.2 Development of the Variable Block Model | 4-13 |
| 4.6.2.1 Developing Reserve Blocks | 4-13 |
| 4.6.2.2 Quality Assignment to Blocks | 4-14 |
| 4.6.2.3 Application of the Variable Block Model | 4-15 |
| 4.6.3 Reserves | 4-15 |
| 4.7 Geostatistics | 4-16 |
| 4.7.1 Preliminary Studies | 4-16 |
| 4.7.2 Sulphur | 4-16 |
| 4.7.3 Research Project | 4-17 |

| | <u>Page</u> |
|---|-------------|
| 5 <u>MINE PLANNING</u> | |
| 5.1 Introduction | 5-1 |
| 5.2 Design Criteria | 5-3 |
| 5.2.1 Powerplant Requirements | 5-3 |
| 5.2.1.1 Powerplant Needs at Target Quality | 5-3 |
| 5.2.1.2 Allowable Coal Quality Variations | 5-4 |
| 5.2.2 Material Delivery Points and Mine Facilities Location | 5-4 |
| 5.2.3 Geotechnical Constraints | 5-5 |
| 5.2.3.1 Introduction | 5-5 |
| 5.2.3.2 The Nature of the Materials in the No. 1 Deposit | 5-6 |
| 5.2.3.3 Geotechnical Conclusions | 5-6 |
| 5.2.3.4 The 35-Year Pit Design | 5-8 |
| 5.2.3.5 Handling Overburden Surficial Deposits | 5-8 |
| 5.2.3.6 Bench Strengths | 5-9 |
| 5.2.3.7 Other Geotechnics | 5-10 |
| 5.2.3.8 Field-Test Knowledge and Experience (Bulk Sample Program) | 5-11 |
| 5.2.3.9 Mining Methods Assumptions | 5-11 |
| 5.2.3.10 Ultimate Slopes | 5-12 |
| 5.2.4 Hydrology | 5-13 |
| 5.2.4.1 The Hydrology Program | 5-13 |
| 5.2.4.2 Hydrological Relationship to Geotechnical Constraints | 5-13 |
| 5.2.4.3 Work Programs and Methods Used to Determine the Hydrology | 5-14 |
| 5.2.4.4 Conclusions | 5-15 |
| 5.2.4.5 The Hydrogeological Picture of the Hat Creek Valley | 5-15 |
| 5.2.4.6 Controls and Preventive Measures | 5-16 |
| 5.2.4.7 Evaluation of Piezometer Hydrographs | 5-17 |
| 5.2.5 Material Characteristics | 5-18 |
| 5.2.5.1 General Description | 5-18 |
| 5.2.5.2 Specific Gravity | 5-20 |
| 5.2.5.3 Swell Factors | 5-21 |
| 5.2.5.4 Material Cutting Resistance | 5-22 |
| 5.2.5.5 Bearing Capacity of Materials | 5-22 |
| 5.2.6 Dilution and Mining Loss | 5-23 |
| 5.2.6.1 Dilution | 5-23 |
| 5.2.6.2 Mining Loss | 5-23 |

| | <u>Page</u> | |
|-------|--|------|
| 5.2.7 | Selective Mining | 5-24 |
| | 5.2.7.1 Definition | 5-24 |
| | 5.2.7.2 Selective Mining Methods | 5-25 |
| | 5.2.7.3 Selective Mining Evaluation | 5-26 |
| 5.3 | Mining Methods | 5-28 |
| | 5.3.1 Review of Alternatives | 5-28 |
| | 5.3.2 The Shovel/Truck/Conveyor System | 5-29 |
| 5.4 | Pit Design and Production Scheduling | 5-34 |
| | 5.4.1 Planning Data | 5-34 |
| | 5.4.2 The Dipper System | 5-34 |
| | 5.4.3 Pit Design | 5-36 |
| | 5.4.4 Production Scheduling | 5-37 |
| 5.5 | Waste Dumps and Embankments | 5-39 |
| | 5.5.1 General | 5-39 |
| | 5.5.2 Geotechnical Constraints and Parameters | 5-39 |
| | 5.5.2.1 Material Parameters | 5-39 |
| | 5.5.2.2 Parameters of Waste Dumps and Embankments | 5-40 |
| | 5.5.3 Construction and Development | 5-41 |
| | 5.5.3.1 Construction of Access Roads and Initial Conveyor Pads | 5-42 |
| | 5.5.3.2 Dumping General Waste | 5-42 |
| | 5.5.3.3 Construction of Embankments | 5-43 |
| | 5.5.4 The Houth Meadows Waste Dump | 5-43 |
| | 5.5.5 The Medicine Creek Waste Dump | 5-45 |
| | 5.5.6 Conclusions and Recommendations Relating to Waste Disposal Embankment Studies | 5-46 |
| | 5.5.6.1 Conclusions | 5-46 |
| | 5.5.6.2 Recommendations | 5-47 |

6 THE MINE DRAINAGE PLAN

| | | |
|-----|---------------------------------------|-----|
| 6.1 | Introduction | 6-1 |
| 6.2 | Mine Water: Source and Quality | 6-2 |
| | 6.2.1 Direct Precipitation and Runoff | 6-2 |
| | 6.2.2 Creeks, Lakes, and Ponds | 6-3 |
| | 6.2.2.1 Creeks | 6-3 |
| | 6.2.2.2 Lakes and Ponds | 6-3 |

| | <u>Page</u> | |
|-----------|---|------|
| 6.2.3 | Groundwater | 6-4 |
| 6.2.4 | Mine Wastewater | 6-5 |
| 6.3 | Mine Drainage System | 6-6 |
| 6.3.1 | Design Criteria | 6-6 |
| 6.3.2 | Drainage of the Mine Development | 6-7 |
| 6.3.2.1 | The Open Pit | 6-7 |
| 6.3.2.2 | South-West Slide Area | 6-8 |
| 6.3.2.3 | Houth Meadows Waste Dump | 6-10 |
| 6.3.2.4 | Medicine Creek Waste Dump | 6-11 |
| 6.3.2.5 | Coal Blending Area | 6-12 |
| 6.3.2.6 | Low-grade Stockpile | 6-12 |
| 6.3.2.7 | Topsoil Storage Areas | 6-12 |
| 6.3.2.8 | Mine Services Area | 6-12 |
| 6.3.2.9 | Mine Roads | 6-13 |
| 6.3.2.10 | Sewage | 6-13 |
| 6.4 | Wastewater Disposal | 6-14 |
| 6.4.1 | Discharge Objectives | 6-14 |
| 6.4.2 | Projected Quality of Mine Drainage | 6-14 |
| 6.4.3 | Proposal Treatment to Meet Objectives | 6-16 |
| 6.4.3.1 | Zero Discharge System | 6-16 |
| 6.4.3.1.1 | General | 6-16 |
| 6.4.3.1.2 | Inflow, Outflow, and Lagoon Capacity | 6-16 |
| 6.4.3.1.3 | North Valley Lagoon | 6-17 |
| 6.4.3.1.4 | Medicine Creek Valley Lagoon | 6-18 |
| 6.4.3.1.5 | Operation | 6-19 |
| 6.4.3.2 | Sedimentation Lagoon System | 6-19 |
| 6.4.3.2.1 | General | 6-19 |
| 6.4.3.2.2 | Design Criteria | 6-20 |
| 6.4.3.2.3 | Inflow | 6-20 |
| 6.4.3.2.4 | Sediment Tests | 6-20 |
| 6.4.3.2.5 | North Valley Lagoons | 6-21 |
| 6.4.3.2.6 | Medicine Creek Lagoons | 6-21 |
| 6.4.3.2.7 | Lagoon Discharge | 6-22 |
| 6.4.3.2.8 | Operation | 6-23 |

7 FUEL QUALITY

| | | |
|-----|--------------|-----|
| 7.1 | Introduction | 7-1 |
|-----|--------------|-----|

| | <u>Page</u> |
|--|-------------|
| 7.2 Hat Creek Coal | 7-2 |
| 7.3 Coal Beneficiation | 7-4 |
| 7.3.1 Testing Program | 7-4 |
| 7.3.2 Conclusions Drawn from Test Results | 7-5 |
| 7.3.3 Alternative Beneficiation Processes Considered | 7-6 |
| 7.3.4 Tailings Disposal | 7-7 |
| 7.3.5 Conclusions | 7-8 |
| 7.4 Boiler Fuel Specification Development | 7-9 |
| 7.4.1 Introduction | 7-9 |
| 7.4.2 Data Assessment | 7-10 |
| 7.4.3 Fuel Assessment | 7-11 |
| 7.4.3.1 Testing Program | 7-11 |
| 7.4.3.2 Comparison with Other Plants | 7-13 |
| 7.4.4 The Boiler Fuel Specification | 7-14 |
| 7.5 Low-grade Coal | 7-15 |
| 7.6 Fuel Quality Control | 7-17 |
| 7.6.1 Introduction | 7-17 |
| 7.6.2 Control Program | 7-17 |
| 7.6.3 Special Operations | 7-19 |

| | | |
|-------|---|------|
| 8 | <u>MATERIALS-HANDLING</u> | |
| 8.1 | Introduction | 8-1 |
| 8.2 | Coal-handling | 8-3 |
| 8.2.1 | Coal-handling System Requirements | 8-3 |
| 8.2.2 | Coal-handling - Design Criteria | 8-3 |
| | 8.2.2.1 Design Features | 8-4 |
| 8.2.3 | Coal-handling Facilities - Basic Description | 8-5 |
| 8.2.4 | Coal-handling - Mining and Powerplant | 8-6 |
| | 8.2.4.1 Coal-handling - Mining | 8-6 |
| | 8.2.4.2 Coal-handling - Powerplant | 8-13 |
| 8.2.5 | Coal System Operation | 8-18 |
| 8.2.6 | Low-grade Coal Facilities | 8-23 |
| 8.2.7 | Low-sulphur Coal | 8-25 |
| 8.2.8 | Coal Sampling | 8-26 |
| | 8.2.8.1 Belt-Sampling - Mine | 8-26 |
| | 8.2.8.2 Belt-Sampling - Powerplant | 8-27 |
| 8.3 | Waste-handling | 8-28 |
| 8.3.1 | Waste-handling System Requirements | 8-28 |
| 8.3.2 | Design Criteria | 8-28 |
| | 8.3.2.1 Design Features | 8-28 |
| 8.3.3 | Waste-handling System - Description | 8-29 |
| 8.3.4 | Waste-handling - In-Pit | 8-29 |
| 8.3.5 | Waste-handling - Houth Meadows | 8-32 |
| 8.3.6 | Waste-handling - Medicine Creek | 8-34 |
| 8.3.7 | Ash-handling - Medicine Creek | 8-34 |
| | 8.3.7.1 Bottom-ash | 8-35 |
| | 8.3.7.2 Fly-ash | 8-36 |
| | 8.3.7.3 Economiser and Airheater Ash | 8-36 |
| | 8.3.7.4 Transportation of Ash to Disposal Area | 8-37 |
| | 8.3.7.5 Ash Disposal, Pile Reclamation, Drainage and Stability | 8-38 |
| 8.4 | Electrical Power Supply | 8-40 |
| 8.4.1 | Mine - Coal, Waste, and Ash-handling | 8-40 |
| 8.4.2 | Powerplant - Coal-handling | 8-40 |

| | <u>Page</u> |
|---|-------------|
| 8.5 Recommendations for Future Testwork | 8-41 |
| 8.5.1 Crushing and General Characteristics of Run-of-Mine Materials and Blended Coal | 8-41 |
| 8.5.2 Borecore Test Program | 8-42 |
| 8.5.3 Crushing Tests | 8-42 |
| 8.5.4 Handling Characteristics | 8-43 |
| 8.5.5 Screening Tests | 8-43 |
| | |
| 9 <u>EQUIPMENT</u> | |
| | |
| 9.1 Production Equipment | 9-1 |
| 9.1.1 Coal Mining | 9-2 |
| 9.1.2 Waste Removal | 9-3 |
| 9.1.3 Operation at Maximum Capacity Rating | 9-5 |
| | |
| 9.2 Support Equipment | 9-7 |
| 9.2.1 Road Construction and Maintenance | 9-7 |
| 9.2.2 Mine Support | 9-8 |
| 9.2.3 Material-handling Support | 9-10 |
| 9.2.4 Service Equipment | 9-11 |
| | |
| 10 <u>MINE SUPPORT FACILITIES</u> | |
| | |
| 10.1 Introduction | 10-1 |
| | |
| 10.2 Mine Services Area | 10-2 |
| 10.2.1 Location | 10-2 |
| 10.2.2 Facilities Required | 10-2 |
| 10.2.2.1 Administration Building | 10-2 |
| 10.2.2.2 Maintenance Complex | 10-3 |
| 10.2.2.3 Mine Services Building | 10-6 |
| 10.2.2.4 Field Maintenance Centre | 10-7 |
| 10.2.2.5 Rubber Repair Shop | 10-7 |
| 10.2.2.6 Laboratories | 10-8 |
| 10.2.2.7 Lubricant Storage Building | 10-9 |
| 10.2.2.8 Fuel Storage and Dispensing Area | 10-10 |
| 10.2.2.9 Mine Dry | 10-11 |
| 10.2.2.10 Storage Areas | 10-11 |

| | <u>Page</u> | |
|--------|--|-------|
| 10.2.3 | Structural Description of Buildings | 10-12 |
| 10.2.4 | Services to Buildings | 10-13 |
| | 10.2.4.1 Water Supply | 10-13 |
| | 10.2.4.2 Electrical Distribution | 10-13 |
| | 10.2.4.3 Heating, Ventilating, and Air Conditioning | 10-14 |
| | 10.2.4.4 Lighting | 10-14 |
| | 10.2.4.5 Sewage Disposal | 10-15 |
| | 10.2.4.6 Fire Protection | 10-15 |
| | 10.2.4.6.1 Mine Services Area | 10-15 |
| | 10.2.4.6.2 Coal Handling Systems | 10-16 |
| | 10.2.4.6.3 Open Pit | 10-17 |
| | 10.2.4.6.4 Waste Conveyors | 10-17 |
| | 10.2.4.6.5 Mine Equipment and Vehicles | 10-17 |
| | 10.2.4.7 Surface Drainage | 10-17 |
| | 10.2.4.8 Security | 10-18 |
| 10.2.5 | Construction Period Requirements | 10-19 |
| | 10.2.5.1 Construction Schedule | 10-20 |
| | 10.2.5.2 Construction Period Facilities | 10-20 |
| | 10.2.5.3 Mine Equipment Erection Area | 10-20 |
| 10.3 | Utilities | 10-21 |
| | 10.3.1 Water Supply | 10-21 |
| | 10.3.1.1 Introduction | 10-21 |
| | 10.3.1.2 Water Requirements | 10-21 |
| | 10.3.1.3 Water Sources | 10-22 |
| | 10.3.1.4 Proposed System | 10-23 |
| | 10.3.1.4.1 Source of Supply | 10-23 |
| | 10.3.1.4.2 Mine Services Area | 10-23 |
| | 10.3.1.4.3 Coal Blending Area | 10-24 |
| | 10.3.1.4.4 Overland Coal Conveyor | 10-24 |
| | 10.3.1.4.5 In-Pit Water Supply | 10-24 |
| | 10.3.1.4.6 Revegetation Nursery | 10-25 |
| | 10.3.2 Mine Power Supply | 10-25 |
| | 10.3.2.1 Introduction | 10-25 |
| | 10.3.2.2 Electrical Loads | 10-25 |
| | 10.3.2.2.1 Power Shovels | 10-25 |
| | 10.3.2.2.2 Voltage Regulations | 10-26 |
| | 10.3.2.2.3 Estimated Annual Power Demands and Energy Consumption | 10-26 |
| | 10.3.2.3 Network Design Criteria | 10-27 |
| | 10.3.2.4 System Description | 10-28 |
| | 10.3.2.4.1 General | 10-28 |
| | 10.3.2.4.2 Pit Area | 10-29 |

| | <u>Page</u> |
|--|-------------|
| 10.3.2.4.3 Houth Meadows Waste Dump | 10-29 |
| 10.3.2.4.4 Medicine Creek Waste Dump | 10-30 |
| 10.3.2.4.5 Mine Service Facilities | 10-31 |
| 10.3.2.4.6 Crushing/Blending Plant | 10-31 |
| 10.3.2.4.7 Reliability | 10-31 |
| 10.3.2.4.8 Construction Power | 10-32 |
| | |
| 11 <u>ENVIRONMENTAL PROTECTION</u> | |
| | |
| 11.1 Introduction | 11-1 |
| 11.2 Dust | 11-2 |
| 11.3 Noise | 11-3 |
| 11.4 Mine Drainage and Water Quality | 11-4 |
| 11.5 Land Reclamation | 11-5 |
| 11.5.1 On-site Reclamation Testing | 11-5 |
| 11.5.2 Waste Dumps and Embankments | 11-8 |
| 11.5.3 Material Storage Areas After Abandonment | 11-9 |
| 11.5.4 Transportation Corridors | 11-9 |
| 11.5.5 Support Facilities | 11-10 |
| 11.5.6 The Open Pit After Abandonment | 11-10 |
| 11.5.7 Disturbances and Possible Resource Losses | 11-11 |
| 11.6 Other Measures | 11-12 |
| 11.6.1 Spontaneous Combustion | 11-12 |
| 11.6.2 Environmental Services Complex | 11-12 |
| 11.6.3 Monitoring | 11-12 |
| 11.6.4 Archaeology | 11-13 |
| 11.7 Costs | 11-14 |
| | |
| 12 <u>CONSTRUCTION SCHEDULE</u> | 12-1 |
| | |
| 13 <u>MANPOWER</u> | 13-1 |

| | <u>Page</u> |
|----------|--|
| 14 | <u>ECONOMICS AND COSTS ESTIMATES</u> |
| 14.1 | Summary 14-1 |
| 14.2 | Estimating Criteria 14-4 |
| 14.2.1 | Introduction 14-4 |
| 14.2.2 | Overall Approach to the Development of the Project Cash Flow 14-4 |
| 14.2.2.1 | Equipment Productivity Standards 14-8 |
| 14.2.2.2 | Equipment Cost Standards 14-8 |
| 14.2.3 | Capital Cost Estimating Criteria 14-9 |
| 14.2.3.1 | Buildings and Civil Works 14-9 |
| 14.2.3.2 | Major Equipment 14-9 |
| 14.2.4 | Operating Cost Estimating Criteria 14-13 |
| 14.2.4.1 | Staff Salaries and Benefits 14-13 |
| 14.2.4.2 | Hourly Labour Rates 14-13 |
| 14.2.4.3 | Mine Operating Schedules 14-14 |
| 14.2.4.4 | Materials Parameters 14-14 |
| 14.2.4.5 | Equipment Parameters 14-15 |
| | 14.2.4.5.1 Drilling and Blasting Equipment 14-15 |
| | 14.2.4.5.2 Loading Equipment 14-15 |
| | 14.2.4.5.3 Haulage Trucks 14-15 |
| | 14.2.4.5.4 Coal and Waste-handling Systems 14-16 |
| 14.3 | Capital Costs 14-34 |
| 14.3.1 | Description of Costs Included in the Major Cost Centres 14-35 |
| 14.3.1.1 | Engineering and Construction 14-35 |
| 14.3.1.2 | Mine Property Development 14-35 |
| 14.3.1.3 | Buildings and Structures 14-35 |
| 14.3.1.4 | Mining Equipment 14-36 |
| 14.3.1.5 | Coal Conveying, Crushing, and Blending Equipment 14-36 |
| 14.3.1.6 | Low-grade Coal Beneficiation Equipment 14-37 |
| 14.3.1.7 | Waste Disposal Equipment 14-37 |
| 14.3.1.8 | Reclamation and Environmental Protection 14-38 |
| 14.3.1.9 | Contingency 14-38 |

| | <u>Page</u> |
|---|-------------|
| 14.4 Operating Costs | 14-41 |
| 14.4.1 Description of Costs Included in the Major Cost Centres | 14-42 |
| 14.4.1.1 Drilling and Blasting | 14-42 |
| 14.4.1.2 Loading and Hauling | 14-42 |
| 14.4.1.3 Coal and Waste-handling Systems | 14-42 |
| 14.4.1.4 Auxiliary Equipment | 14-43 |
| 14.4.1.5 Power | 14-43 |
| 14.4.1.6 General Mine Expense | 14-43 |
| 14.4.1.7 Overhead | 14-46 |
| 14.4.1.8 Royalties | 14-48 |
| 14.4.1.9 Contingency | 14-48 |
| 14.4.1.10 Contractor's Allowance | 14-48 |
| | |
| 15 <u>MINING REPORTS AND STUDIES</u> | 15-1 |

VOLUME 1

| <u>No.</u> | <u>LIST OF TABLES</u> | <u>Page</u> |
|------------|--|-------------|
| 4-1 | Summary of Drilling | 4-18 |
| 4-2 | Regional Stratigraphy | 4-19 |
| 4-3 | Development of Stratigraphic Subdivision | 4-20 |
| 4-4 | Summary of Proximate and Ash Analyses | 4-21 |
| 4-5 | Sulphur Forms | 4-22 |
| 4-6 | Reserve Estimation by Sub-zones with 2 m Minimum Thickness | 4-23 |
| 4-7 | Reserve Estimation by Benches with 2 m Minimum Thickness | 4-24 |
| 4-8 | Reserve Estimation with Non-Selective Mining at 9.3 MJ/kg Cut-off | 4-25 |
| 4-9 | Reserve Estimation with Non-Selective Mining at 6.98 MJ/kg Cut-off | 4-26 |
| 4-10 | Total Sulphur Distribution in Sub-zones of No. 1 Deposit | 4-27 |
| 4-11 | Kriging Parameters | 4-28 |
| 4-12 | Sulphur Distribution in Sub-zone A5 | 4-29 |
| 5-1 | Description of Surficial Materials | 5-48 |
| 5-2 | Description of Rock Materials | 5-49 |
| 5-3 | Hydraulic Conductivity Results | 5-50 |
| 5-4 | Incremental Design Pit Quantities | 5-51 |

| <u>No.</u> | | <u>Page</u> |
|------------|---|-------------|
| 5-5 | Adjusted Production Schedule | 5-52 |
| 5-6 | Schedule Annual Production | 5-53 |
| 5-7 | Houth Meadows Waste Dump - Capacity by Lift | 5-54 |
| 5-8 | Medicine Creek Waste Dump - Capacity by Lift | 5-55 |
| 6-1 | Projected Groundwater Yield from the Mine Development | 6-24 |
| 6-2 | Design Criteria for Planning of the Mine Drainage System | 6-25 |
| 6-3 | Design Flows for Preliminary Planning of the Mine Drainage System | 6-26 |
| 6-4 | Projections of Water Quality of Mine Drainage | 6-27 |
| 6-5 | Estimated Sedimentation Lagoon Inflow: Year 35 | 6-28 |
| 6-6 | Projected Quality of Lagoon Discharge and Hat Creek - Case III | 6-29 |
| 7-1 | Classification of Hat Creek Coal | 7-20 |
| 7-2 | Comparison of Hat Creek and San Miguel Fuel Characteristics | 7-21 |
| 7-3 | Boiler Fuel Specification | 7-22 |
| 7-4 | Size Consist - Powerplant Feed | 7-24 |

VOLUME 2

| <u>No.</u> | <u>LIST OF TABLES</u> | <u>Page</u> |
|------------|--|-------------|
| 8-1 | In-pit Crushing Plant - Transfer Conveyors | 8-44 |
| 8-2 | In-pit Incline - Coal and Waste Conveyors | 8-45 |
| 8-3 | Crushing, Stacking Reclaiming, and Delivery Conveyors | 8-46 |
| 8-4 | Low-grade Coal - Plant Conveyors | 8-47 |
| 8-5 | Houth Meadows Dump - Waste Conveyors | 8-48 |
| 8-6 | Medicine Creek Dump - Waste Conveyors | 8-49 |
| 8-7 | Powerplant Coal-handling Conveyors | 8-50 |
| 8-8 | Ash-handling Conveyors | 8-51 |
| 8-9 | Operating Regime - Examples of Various Operating Conditions | 8-52 |
| 9-1 | Mine Equipment List | 9-13 |
| 9-2 | Roads Scheduled for Construction | 9-18 |
| 10-1 | Preliminary Estimates of Consumptive Water Requirements | 10-33 |
| 10-2 | Water Quality Data | 10-34 |
| 10-3 | Total Estimated Mine Load During Peak Years | 10-35 |
| 10-4 | Estimated Annual Load and Energy Demands | 10-36 |
| 11-1 | Estimate of Areas Disturbed and Reclaimed by Year 35 and Year 45 | 11-15 |
| 12-1 | Mine Development and Construction Schedule | 12-1 |

| <u>No.</u> | | <u>Page</u> |
|------------|---|-------------|
| 13-1 | Schedule of Peak Manpower Requirements | 13-1 |
| 13-2 | Manpower Schedule - Summary | 13-5 |
| 14-1 | Summary of Annual Costs | 14-2 |
| 14-2 | Breakdown of Total Estimated Capital and Operating Expenditures by Major Cost Centres | 14-3 |
| 14-3 | Equipment Capital Costs and Service Lives | 14-10 |
| 14-4 | Annual Salaries of Mine Staff | 14-18 |
| 14-5 | Labour Rates for Mine Operations Staff | 14-19 |
| 14-6 | Productivity Standards for Functional Cost Centres | 14-20 |
| 14-7 | Standard Costs for Functional Cost Centres | 14-28 |
| 14-8 | Development of Capital Costs for Major Mine Equipment | 14-39 |
| 14-9 | Summary of Capital Costs by Major Cost Centres | 14-40 |
| 14-10 | Development of Operating Costs for Functional Cost Centres | 14-49 |
| 14-11 | Summary of Operating Costs by Major Cost Centres | 14-59 |
| 14-12 | Other Costs Allocated to Mining Project | 14-63 |

VOLUME 1

| <u>No.</u> | <u>LIST OF FIGURES</u> | <u>Page</u> |
|------------|--|-------------|
| 3-1 | Project Location | 3-11 |
| 3-2 | Project Complex Map | 3-12 |
| 3-3 | Detailed Site Layout Map | 3-13 |
| 3-4 | Hat Creek Project, View from SE | 3-14 |
| 3-5 | Hat Creek Project, Powerplant from West | 3-15 |
| | | |
| 4-1 | Geophysical Log DH 274, showing the 16 sub-zones | 4-30 |
| 4-2 | Regional Bedrock Geology | 4-31 |
| 4-3 | Geological Cross-section Q | 4-32 |
| 4-4A | Geological Cross-section 18 N | 4-33 |
| 4-4B | Geological Cross-section 18 S | 4-34 |
| 4-5 | Ash-Heating Value Regression Curve (Ash <60%) | 4-35 |
| 4-6 | Sample Semi-Variogram, Sulphur - Sub-zone A2 | 4-36 |
| | | |
| 5-1 | Interim Pit Development: Cross-section Q | 5-56 |
| 5-2 | Uniaxial Compressive Strengths | 5-57 |
| 5-3 | Pit Slopes | 5-58 |
| 5-4 | Generalized Piezometric Surface Contours of Bedrock Materials | 5-59 |
| 5-5 | Hydraulic Conductivity Values Determined In Situ | 5-60 |
| 5-6 | Hydrology, Section Through Hat Creek Valley | 5-61 |

| <u>No.</u> | | <u>Page</u> |
|------------|--|-------------|
| 5-7 | Mine Seepage and Dewatering Flow Chart | 5-62 |
| 5-8 | Depressurization by Excavation | 5-63 |
| 5-9 | Typical VBM Cross-section | 5-64 |
| 5-10 | Bench Plan - Elevation 775 | 5-65 |
| 5-11 | Cone Geometry | 5-66 |
| 5-12 | Pit Development Year -1 | 5-67 |
| 5-13 | Pit Development Year 5 | 5-68 |
| 5-14 | Pit Development Year 8 | 5-69 |
| 5-15 | Pit Development Year 15 | 5-70 |
| 5-16 | Pit Development Year 25 | 5-71 |
| 5-17 | Pit Development Year 35 | 5-72 |
| 5-18 | Dump Development | 5-73 |
| 5-19 | Houth Meadows Dump | 5-74 |
| 5-20 | Medicine Creek Dump | 5-75 |
| 5-21 | Waste Dump Slopes | 5-76 |
| 6-1 | Precipitation Data | 6-30 |
| 6-2 | Streamflow Data | 6-31 |
| 6-3 | Mine Drainage Schematic | 6-32 |
| 6-4 | Mine Drainage Plan | 6-33 |
| 6-5 | Zero Discharge Hydrographs - Year 35 | 6-34 |
| 6-6 | Sedimentation Lagoons: Mean Monthly Discharge | 6-35 |
| 6-7 | Sedimentation Lagoons: 10-Year 24-Hour Flood Discharge Hydrographs | 6-36 |

VOLUME 2

| <u>No.</u> | <u>LIST OF FIGURES</u> | <u>Page</u> |
|------------|---|-------------|
| 8-1 | Overall Project Flow Diagram | 8-54 |
| 8-2 | Materials-handling System Flow Diagram | 8-55 |
| 8-3 | Mine Conveyors and Truck Dump Stations - General Arrangement | 8-56 |
| 8-4 | Screening and Crushing - General Arrangement | 8-57 |
| 8-5 | Blending/Reclaiming - General Arrangement | 8-58 |
| 8-6 | Overland Coal Conveyor - General Arrangement | 8-59 |
| 8-7 | Waste Dump Development - Pictorial View | 8-60 |
| 8-8 | Powerplant - Plot Plan | 8-61 |
| 8-9 | Powerplant - Flow Diagram of Coal System | 8-62 |
| 8-10 | Powerplant - Flow Diagram - Bottom-ash Removal | 8-63 |
| 8-11 | Powerplant - General Arrangement - Drag-bar Conveyor for Bottom-ash | 8-64 |
| 8-12 | Powerplant - Flow Diagram - Fly-ash Pressure System | 8-65 |
| 8-13 | Powerplant - Ash-handling Scheme | 8-66 |
| 8-14 | Powerplant - Ash Disposal System - Isometric View | 8-67 |
| 10-1 | Mine Services Area - General Arrangement | 10-37 |
| 10-2 | Administration Building | 10-38 |
| 10-3 | Maintenance Complex | 10-39 |
| 10-4 | Mine Services Building and Rubber Repair Shop | 10-40 |
| 10-5 | Mine Dry | 10-41 |

| <u>No.</u> | | <u>Page</u> |
|------------|---|-------------|
| 10-6 | Mine Power Distribution Network | 10-42 |
| 10-7 | Typical Portable Sub-station Layout | 10-43 |
| 10-8 | Typical Permanent Sub-station Layout | 10-44 |
| 11-1 | Map of Reclamation by Year 45 | 11-16 |
| 13-1 | Organization Chart | 13-6 |
| 14-1 | Overall Approach to Development of Cash Flow | 14-5 |
| 14-2 | Development of Equipment Productivity Standards | 14-6 |
| 14-3 | Development of Standard Costs Per Shift for Machine Operations | 14-7 |

SECTION 1

INTRODUCTION

This mining report is the culmination of five years' work by a task force of B.C. Hydro's Thermal Division and its consultants to develop and to establish the feasibility of a base plan which, by adding a 500 MW unit in each of four successive years, would exploit the rich coal deposits of the Hat Creek Valley for the generation of electricity. A mass of data has been accumulated and analysed, and a point has now been reached when, both on practical and economic grounds, application to the regulatory authorities for necessary licences may be made with confidence.

While many options for the use of the Hat Creek coal deposits have been explored during the past five years, the work in 1979 has concentrated on finalizing the base plan. This has now been achieved. The plan, described in detail in the following sections, deals with the extraction of part of the coal in the No. 1 Deposit by means of hydraulic shovels, trucks, and conveyors, over the 35-year projected lifetime of a 2,000 MW powerplant. The mine mouth powerplant (which consists of 4 x 500 MW units) would be built on the top of the hill above Harry Lake. Any changes to the base plan are likely to be minor and confined mainly to advances in technology.

This report is based upon detailed consultants' reports, and incorporates the results of extensive studies conducted in 1979 by the Mining Department of B.C. Hydro.

In debating whether or not to go ahead with the Hat Creek Project, it may be worth reflecting on how fortunate are the people of British Columbia in possessing what appear to be the world's thickest deposits of thermal coal, located furthermore almost ideally from the point of view of access and mining. Using approximately only half of the proven reserves in the No. 1 Deposit would fuel the powerplant for 35 years, leaving the balance, plus the untouched and much larger No. 2 Deposit, for the benefit of future generations.

The energy crisis having forced a universal re-assessment of coal as an energy resource, coal-owning countries are everywhere engaged in constructing new mines for the purpose of generating power. As an example, at a new coal field in South Africa, four mines have been

developed and are supplying fuel to three 3,600 MW powerplants. A fifth mine, developed in less than four years from the planning stage to full production, is now exporting substantial quantities of thermal coal. The power generated from this single field will amount to more than seven times the proposed capacity of the Hat Creek Project. Closer to home, Oregon and Washington are embarked on a 20-year program of constructing no less than eight thermal plants based on coal from a newly developed field in Washington. A lengthening list of new mine construction reflects the re-awakening of interest in coal as a source of power.

It has been adequately proved that an efficient technology exists to mine coal and burn it to produce electricity. This report shows how such technology can be tailored to cope with the complexities of the Hat Creek No. 1 Coal Deposit. Should the project be approved, it would result not only in British Columbia's first major coal-fired powerplant, but be the first step towards developing many possible alternative industrial uses for the coal, and a significant broadening of the base of British Columbia's whole economy.

| | | |
|-----|--|-------------|
| 2 | <u>SUMMARY</u> | <u>Page</u> |
| 2.1 | Mining Studies Performed - April 1974 to December 1978 | 1 |
| 2.2 | 1979 Studies | 3 |
| 2.3 | Consultants Employed | 5 |

SECTION 2

SUMMARY

2.1 MINING STUDIES PERFORMED - APRIL 1974 TO DECEMBER 1978

Exploration Drilling

Extensive diamond core-drilling between 1974 and 1978 identified two deposits, the smaller of which is estimated to contain in excess of 700 million tonnes. Since 1974, 270 core-holes totalling 75,800 m in length have been drilled. 206 of these holes, on a 150 m by 150 m grid-pattern totalling 54,000 m, have been drilled in the No. 1 Deposit. A further 19,800 m of drilling was completed in pursuit of geotechnical, geohydrological, and other investigation.

The results of these drilling programs, which were conducted under the supervision of Dolmage Campbell and Associates Ltd. and the B.C. Hydro Mining Department, have provided the basis for successive geological interpretations and evaluations of the quality of the coal in the deposit by DCA, CMJV and, most recently, by BCH. Reserves in excess of 700 million tonnes have been established for the No. 1 Deposit. The No. 2 Deposit has been identified as a potentially much larger resource.

Geotechnical and Geohydrological Studies

An assessment and exploration program initiated and assigned to Golder Associates in 1976 has now established a safe overall pit slope angle of 16° , which can in some areas rise to 25° , depending on pit wall materials. The same studies have also established waste dump design parameters. A satisfactory level of confidence in data relating to mine design now exists.

A geohydrological program to determine whether pit slope stability can be improved by reducing groundwater pressure has indicated that limited depressurization can be achieved. Geotechnical monitoring will have to continue throughout the life of the mine.

Mining Studies

PD-NCB Consultants, commissioned in 1975 to perform conceptual design studies, recommended that future work should be concentrated on the No. 1 Deposit. The Cominco-Monenco Joint Venture were engaged in 1977 to undertake preliminary engineering design studies. After investigating alternatives, their report submitted in 1978 recommended a design for an open-pit mine to supply 350 million tonnes of coal averaging 17.0 MJ/kg, on a dry basis, over a period of 35 years, requiring the removal of 450 million m³ of waste. The proposed open-pit would cover an area 3 km by 2.5 km and be 265 m deep, using a shovel-truck-conveyor mining system, with coal-crushing, blending, and stock-piling facilities at the mine mouth. Blended coal would be moved by conveyor to the powerplant 4 km away and 500 m above the valley floor. Waste would move by conveyor to disposal areas at Houth Meadows and Medicine Creek.

The Bulk Sample Program

In 1977, a bulk sample of 6,300 t was excavated from two trenches in the No. 1 Deposit for a burn test. This pilot-scale operation provided valuable data on the mining, handling, and storage of coal and waste materials. Equally valuable was the experience gained in using hydraulic shovels. This proved that the coal can be satisfactorily extracted without blasting, with the exception of a few isolated pockets of rock.

Coal Beneficiation

Bench tests and pilot-scale tests conducted in 1976 established the difficulty of washing Hat Creek coal. Further tests by Simon-Carves on samples from the trenches using modified procedures confirmed and explained the original findings. A pilot-scale test in 1977 involved a 73-t sample. This indicated that coal-washing (beneficiation) was practical, though not justified at present for Hat Creek coal on technical and economic grounds.

During 1979, the previous mining studies were re-evaluated incorporating all the new data acquired in 1978. Major new studies were conducted in the areas of Coal Quality, Pit Design, Production Scheduling, Materials-handling, and Selective Mining. The results of these studies were integrated with those parts of the previous studies that were unchanged and a revised cost estimate and schedule was prepared.

The final results of this work program are presented in detail in the remainder of this report. Some of the key results are:

- (1) 331 million tonnes of coal will be mined over the life of the powerplant, necessitating the removal and disposal of approximately 427 million m³ of waste;
- (2) The powerplant will be supplied with a blended fuel averaging 18.0 MJ/kg, 33.5% ash and 0.51% sulphur on a dry-coal basis, with a moisture content of 23.5%. This fuel will be supplied within a tolerance of ±1 MJ/kg on heating value;
- (3) The improved coal quality results from the use of hydraulic shovels applying selective mining techniques;
- (4) The pit has been redesigned and the production rescheduled, which has resulted in a major reduction in pre-production stripping from 20 million m³ to under 7 million m³;
- (5) The Materials-handling System has been substantially redesigned and conveyor belt widths generally have been increased from 1,200 mm to 1,400 mm;
- (6) Peak manpower levels have been reduced from 1,005 to 875;
- (7) The coal quality characteristics have been evaluated by a specialist consultant and a boiler fuel specification produced;
- (8) Summary of estimated mine costs (October 1979 Canadian dollars)
 1. Capital cost to full production in Year 4 (costs to end of Year 3) \$248 million;
 2. Pre-production operating costs to start of commercial production in Year 1 \$55 million;

3. Additional capital costs during project life (primarily for equipment replacement) \$290 million;
 4. Operating costs per tonne of coal during full production range from \$4.71 to \$5.81;
- (9) Levelized fuel costs over the project life, uninflated and discounted at 3%, are \$0.567/GJ (\$7.80 per tonne of coal), excluding the cost of power consumed in the mining operation. This is equivalent to 6.19 mills/kW.h. Power costs are \$0.47 per tonne based on 20-mill power.

CONSULTANTS EMPLOYED

The following consulting firms have performed assignments related to the Hat Creek Mining Studies:

- (1) Geological Exploration 1974-1978

Dolmage Campbell and Associates (DCA)

- (2) Mine Conceptual Design 1976-1977

Powell Duffryn-National Coal Board (PD-NCB) in association with Wright Engineers Limited and Golder Associates

- (3) Geotechnics and Hydrology 1977-1978

Golder Associates

- (4) Mine Feasibility Studies 1977-1978

Cominco-Monenco Joint Venture (CMJV) with sub-consultants: North American Mining Consultants Inc. (NAMCO); Simon-Carves of Canada Ltd.; MBB Mechanical Services

- (5) Materials-handling and Low-grade Coal Beneficiation 1979

Simon-Carves of Canada Ltd.

- (6) Coal Fuel Specification 1979

Paul Weir Company (WEIRCO)

- (7) Geostatistics 1978-1979

Mineral Exploration Research Institute (IREM-MERI)

- (8) Coal Deposit Computer Modelling 1978-1979

Mintec Inc.

| | | |
|-----|---|-------------|
| 3 | <u>A PROJECT DESCRIPTION</u> | <u>Page</u> |
| 3.1 | The Plan | 1 |
| 3.2 | A History of the Project | 2 |
| 3.3 | The Location of Mine and Powerplant | 3 |
| 3.4 | The Resource: Coal | 4 |
| 3.5 | The Project | 5 |
| 3.6 | The Mining Method | 6 |
| 3.7 | The Powerplant | 8 |
| 3.8 | Powerplant Emissions and Waste | 9 |
| 3.9 | Two Key Areas: Drainage and Reclamation | 10 |

| <u>No.</u> | <u>LIST OF FIGURES</u> | <u>Page</u> |
|------------|---|-------------|
| 3-1 | Project Location | 11 |
| 3-2 | Project Complex Map | 12 |
| 3-3 | Detailed Site Layout Map | 13 |
| 3-4 | Hat Creek Project, View from SE | 14 |
| 3-5 | Hat Creek Project, Powerplant from West | 15 |

SECTION 3

A PROJECT DESCRIPTION

3.1

THE PLAN

The Upper Hat Creek Valley of South Central British Columbia contains the thickest deposits of thermal coal so far discovered in the world. An estimate suggests that up to 15 billion tonnes could exist in the area, although only two deposits have so far been identified which permit coal to be extracted by open-pit mining. Of these, the No. 1 Deposit is estimated to contain over 700 million tonnes, the No. 2 Deposit over a billion tonnes.

The Hat Creek Project is a plan to extract some of the coal from the smaller No. 1 Deposit and to burn it for the purpose of generating electricity. This would create some 1,000 steady jobs at the mine, apart from 3,000 temporary construction jobs. Should the project be approved and licensed, it would broaden the traditional base of hydro-power generation in British Columbia by starting to use coal, a major alternative resource.

The existence of coal deposits in the Hat Creek Valley has been known for over a century, having first been reported in 1877 by G.M. Dawson, of the Geological Survey of Canada. Since then, various private titleholders have made sporadic attempts to mine the coal and to sell it. They all failed for lack of markets and the ability to operate on a sufficiently economic scale. More recently, substantial coal reserves were identified in 1944. In 1957, a subsidiary of the B.C. Electric Co. (a predecessor of B.C. Hydro) began a systematic exploration of the deposits. These explorations have continued on an expanding scale, culminating in a feasibility study which concluded that the project would be both technically practical and economically desirable. B.C. Hydro established a Thermal Division in 1974. Its engineers have written this report.

While the mine is to be located in the Upper Hat Creek Valley, about 200 km North-East of Vancouver, the location of the powerplant is optional. Eight alternatives were considered. The site chosen was largely dictated by environmental imperatives - a hillside, about 4 km from the open pit and at an elevation about 500 m higher than the valley floor. Good dispersal of emissions is ensured by a chimney rising an additional 244 m.

The quality of coal in the No. 1 Deposit appears to vary over an unusually wide range, from less than 9.0 MJ/kg to 23.0 MJ/kg. The overall average is 17.7 MJ/kg, approximately one-half that of high quality bituminous coal found in the East Kootenays, the Rocky Mountain Belt of B.C., and in the Eastern United States. Variations in the quality of Hat Creek coal, added to the high moisture and ash content, are problems that have been provided for in the design of the power-plant. It has also been taken into account in studies leading to the choice of the mining method: a process of selective mining and blending, which will ensure production of a fuel averaging 18.0 MJ/kg, 33.5% ash and 0.51% sulphur on a dry-coal basis, with a moisture content of 23.5%. Geologically, 16 sub-zones have been identified in the Hat Creek Coal Formation. Two of these sub-zones are largely composed of waste, with the other 14 consisting of coal of varying quality.

THE PROJECT

Design studies have defined the major constraints and requirements of the project which features:

- (1) A large open-pit mine, with adjoining waste disposal areas, at the North end of the Hat Creek Valley;
- (2) A powerplant containing four coal-fired boilers, operating steam-driven turbine generators, located on high ground some 4 km East of the open pit;
- (3) A combination of hydraulic shovels, trucks, and belt conveyors, to mine and move both coal and waste;
- (4) A diversion of Hat Creek and Finney Creek around the open pit with the necessary headworks, spillways, canals, etc.;
- (5) A cooling water reservoir supplied by a 21 km buried pipeline from a pumphouse on the Thompson River;
- (6) Two large waste disposal areas, which would gradually be covered with topsoil and landscaped.

THE MINING METHOD

A plan has been drawn up whereby part of the No. 1 Deposit would supply coal for operating a 2,000 MW powerplant over a 35-year lifespan. The coal would be mined from an open pit developed to a depth of 235 m below the valley floor. There is enough coal above this elevation to meet the planned requirements of the powerplant. In Year 35, the open pit would measure approximately 4 km by 2½ km, with a circumference of around 16 km. The surface area of the hole would measure around 598 ha.

Berms (benches) about 18 m wide would step down to the pit bottom, with overall slopes at an angle varying from 16° to 25°, based on geotechnical calculations. It is proposed to remove 331 million tonnes of coal over 35 years, together with 427 million m³ of waste materials, some of which would be stockpiled for construction needs.

A ramp would be cut towards the heart of the No. 1 Deposit for the main conveyors installed to transport coal and waste up to the surface. Some of the topsoil would be stockpiled for use during reclamation. Both coal and waste rock would be mined by using large hydraulic shovels and trucks. The trucks would haul both coal and waste to loading pockets at the conveyor where, after brushing to -200 mm, the material will be transported to the top of the ramp for subsequent distribution along another system of conveyors.

The coal would be mined according to a plan designed to provide a mixture of the right quality. Coal of poorer quality would be moved by conveyors to a dry beneficiation plant, where some of the impurities would be removed by a crushing and screening process which would raise the heating value to an acceptable level. Coal not requiring beneficiation would move direct to a coal preparation area, where it would be screened, crushed to -50 mm, and conveyed to the Coal Blending Area. Here slewing stackers using the Windrow Method would build up stockpiles of blended fuel ready to be reclaimed and transported by an overland conveyor to the powerplant.

The waste material would be moved by conveyors to either of two waste dumps, the larger in Houth Meadows, the smaller in the Medicine Creek area. Both dumps were chosen because their location, though conveniently adjacent to the open pit, would not interfere with future mining. Houth Meadows is expected to take all the waste excavated during the first 15 years, with both dumps being used from Year 16 on. Medicine Creek will also be used to dump the anticipated 10,000 t/d of

both fly-ash from the electrostatic precipitators and bottom-ash from the furnace bottoms. Both waste rock and ash would be spread in the dumps by stackers, and all dump surfaces would ultimately be levelled, contoured, and landscaped when the mine closes.

THE POWERPLANT

The powerplant, with four 500 MW (net) units, would be located on high ground near Harry Lake, some 4 km East of the open pit. The ground level of the powerplant is 1,410 m above sea level, which is about 500 m higher than the ground level at the surface at Open Pit No. 1.

Each water tube boiler would be about 95 m high, with furnace dimension about 18 m square, followed by numerous surfaces containing steam and/or water, to which hot gases leaving the furnace transfer heat. At full load each boiler would consume about 407 t/h of typical Hat Creek coal to produce 1,750 t/h of high-pressure steam.

Electricity would be generated in the powerplant by four steam turbine-generators, each capable of generating 560 MW (gross) for a total net capacity of 2,000 MW.

At the turbine exhaust, a condenser condenses the steam to water after it has done its work. The water is then returned to the boiler to be converted into steam, which is a closed cycle. A condenser does, however, require large quantities of cold water flowing through it to condense the exhaust steam. In providing cooling for the condenser, the cooling water itself warms up, and the heat it has gained must be dissipated. As it would be harmful to the environment to discharge this heated water into the natural water system, the Hat Creek method of cooling provides for two cooling towers, each rising to a height of 135 m. The heated water leaving the condensers is piped into the cooling towers, where it is allowed to cascade down to the bottom, passing in droplet form over a latticework. Air flowing upwards through the tower is heated as the water is cooled, most of the heat transfer being latent heat from the portion of the water which evaporates. Make-up water must be added to replace this evaporative loss to the atmosphere. This is pumped from the plant reservoir, containing roughly a two-month supply. The reservoir is replenished from the Thompson River through a 21 km buried water pipeline.

A vital factor in the powerplant design and operation is an acceptable environmental impact. Both air and water quality control systems have therefore been incorporated into the design.

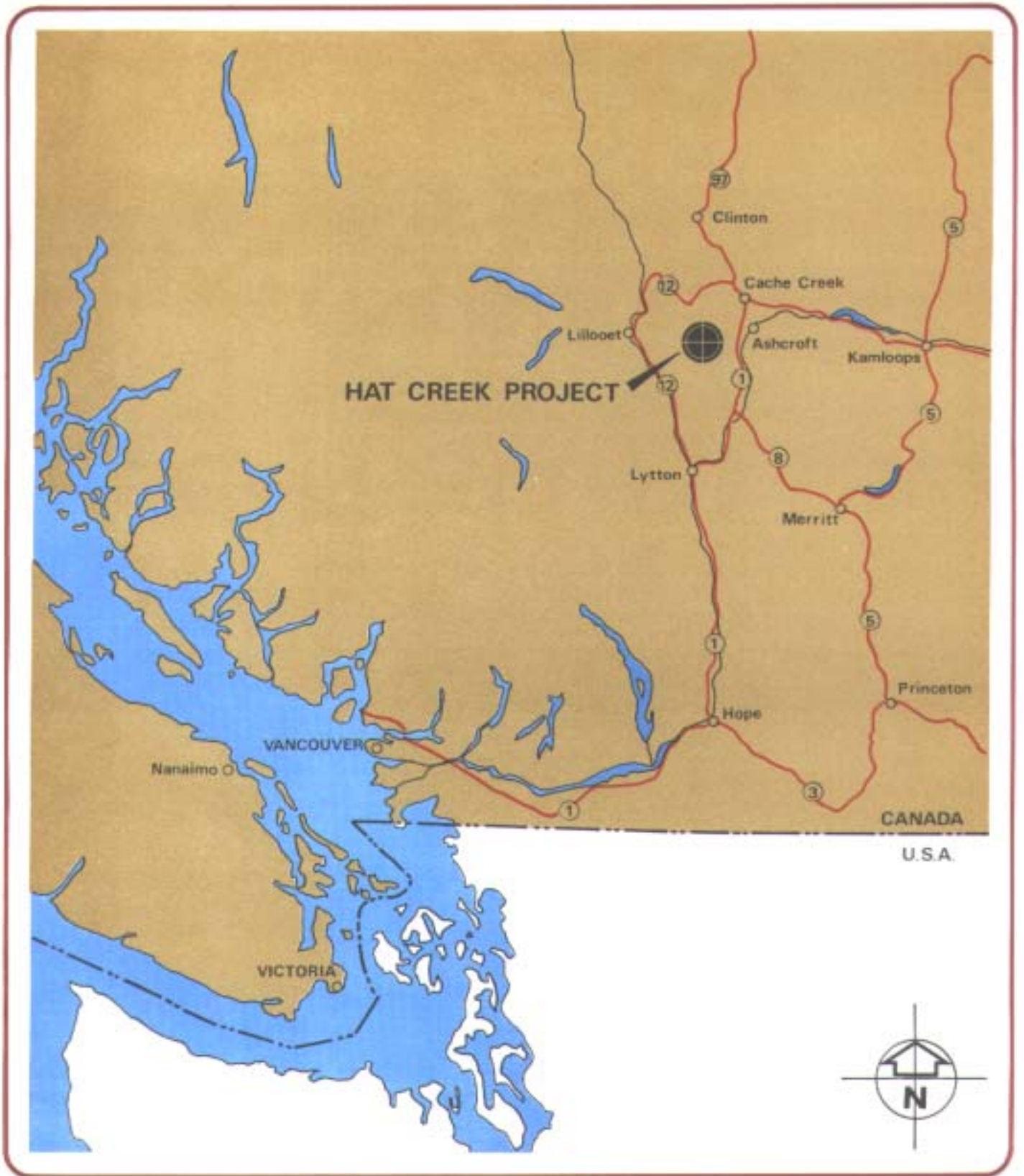
Air quality measures include location of the plant high above the valley, a 244 m high multiflue stack, and cold electrostatic precipitators, capable of trapping 99.55% of the particulates. Space has been left for possibly adding, later, flue gas desulphurization. Hat Creek performance coal contains only 0.51% sulphur on a dry basis. When abnormal atmospheric conditions are predicted which may cause ambient SO₂ levels to increase, a MCS (Meteorological Control System) will be applied. This will involve either switching to low-sulphur coal or reducing the load. Oxides of nitrogen emissions will be controlled by appropriate design and operation of the boilers.

10,000 t of ash will be produced daily. Fly-ash will be wetted and conveyed, with bottom-ash, to a "dry" disposal area in the Medicine Creek Valley below the dam for the plant reservoir. Bottom-ash will be continuously removed from below the boilers. The ash disposal area would be progressively covered with topsoil and landscaped over the lifetime of the project.

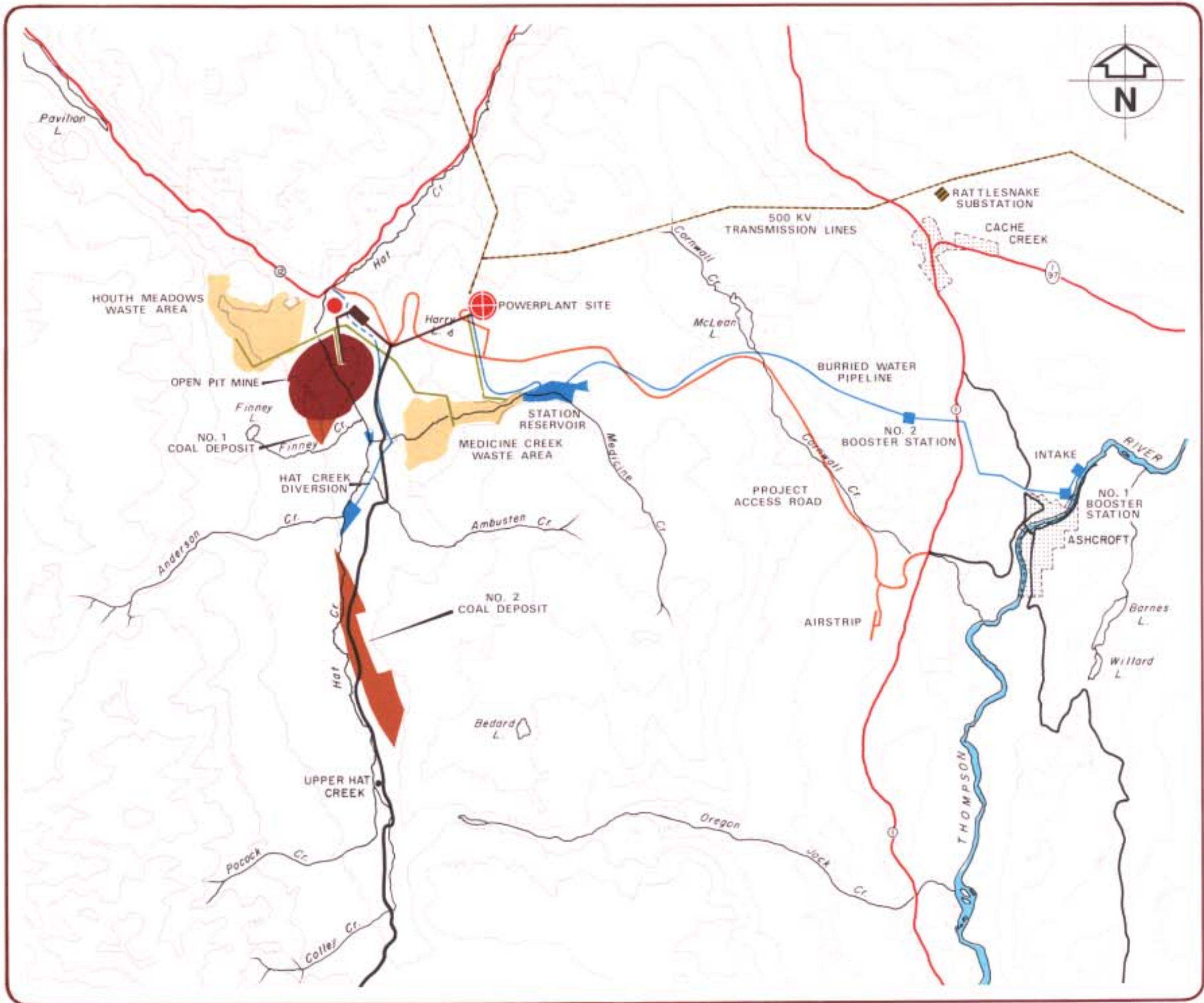
Both drainage and reclamation of disturbed land are related and inter-acting. With several difficult landslide areas along the West side, a comprehensive mine drainage plan is a pre-condition of successful mine development. The drainage plan developed for Hat Creek is designed to meet the difficult ground conditions revealed by exploration. It includes an inter-locking system of diversions, dikes, ditches, de-watering wells, and the provision of lagoons to trap sediments and leachates. Prior to construction, an area of ponds and lakes would be drained of water which might mobilize the already unstable ground in the slide areas.

In terms of environmental protection, the drainage plan ensures that water-borne contaminants will be trapped and disposed of; only water purified to an acceptable degree will be allowed to re-enter the natural water courses. Flows will also be handled in such a way as to re-establish wetland habitats for wildlife.

The guiding rule governing land reclamation would be to reclaim progressively those areas which permit restoration concurrently with operation of the mine (e.g. the ash dump in Medicine Creek), and to budget for extensive reclamation once the mine closes. 96% of the land disturbed during the lifetime of the mine (except the open pit) will be levelled, contoured, covered with topsoil, and seeded or re-planted with shrubs and trees, the objective being to restore it as closely as possible to its former condition. Most of the remaining 4% would be accounted for in the need to retain access roads, reservoirs, drainage ditches and the like for the purpose of continued monitoring of water quality, etc. It is estimated that this reclamation program will cost \$40 million over the lifetime of the mine.

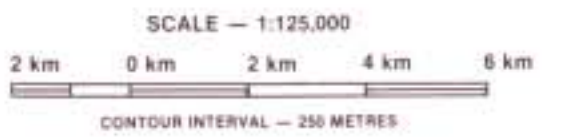


HAT CREEK PROJECT
FIGURE 3-1
PROJECT LOCATION



LEGEND

-  POWERPLANT SITE
-  MINE MAINTENANCE COMPLEX
-  COAL BLENDING AREA AND COAL CONVEYORS
-  WASTE CONVEYORS
-  COAL DEPOSIT AREAS
-  35 YEAR OPEN PIT MINE
-  WASTE DISPOSAL AREAS
-  RESERVOIRS, WATER SUPPLY PIPELINE AND HAT CREEK DIVERSION

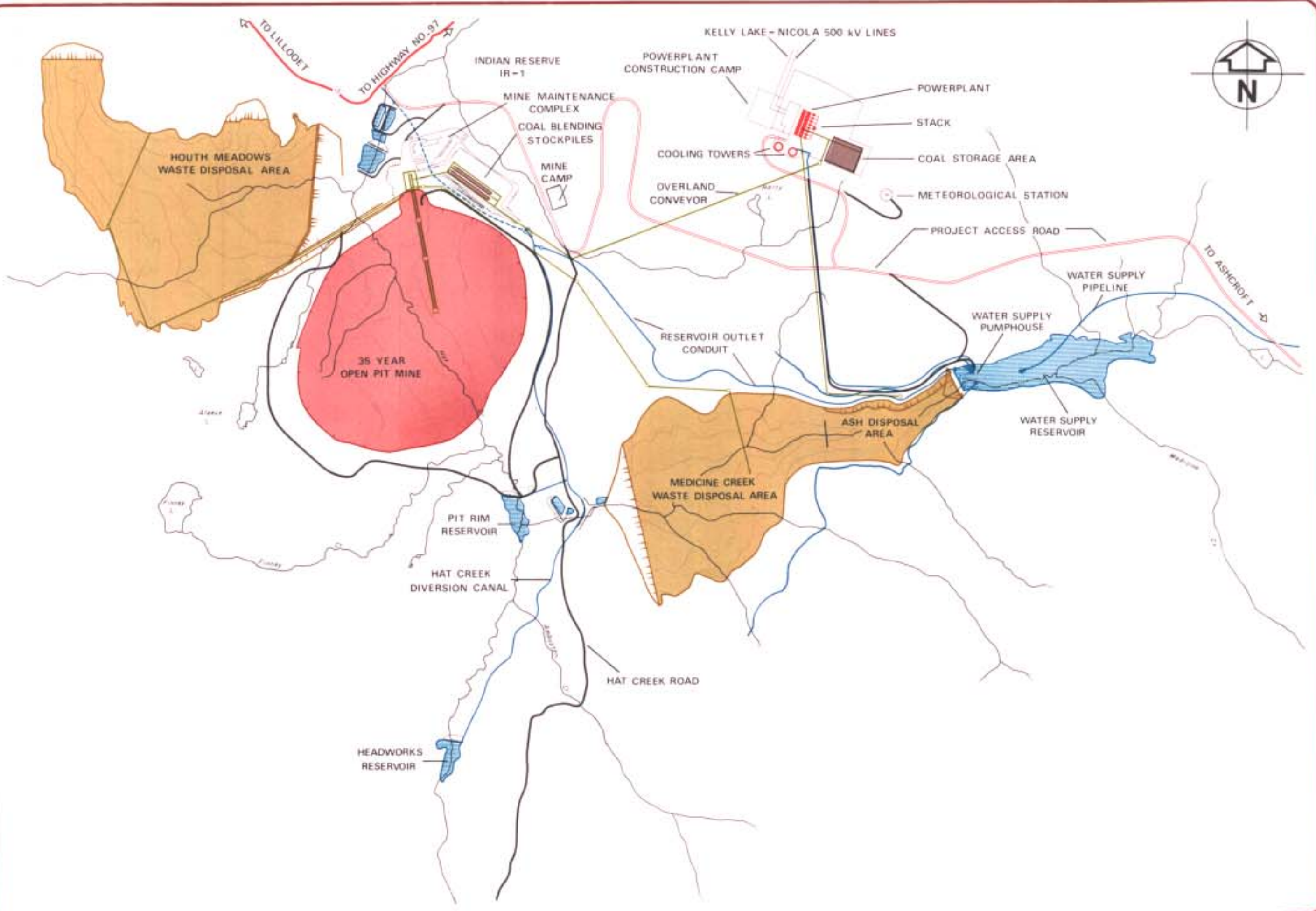


HAT CREEK PROJECT

FIGURE 3.2

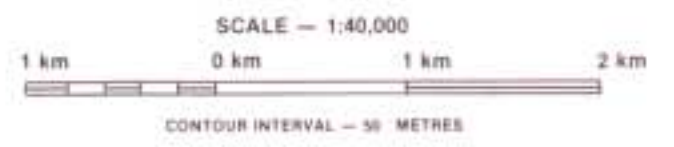
PROJECT COMPLEX MAP

SOURCE: British Columbia Hydro and Power Authority (2)



LEGEND

- 35 YEAR OPEN PIT MINE
- WASTE DISPOSAL AREAS
- COAL BLENDING AND COAL STORAGE AREAS
- RESERVOIRS AND LAGOONS
- CONVEYORS
- WATER SUPPLY, DRAINAGE AND DIVERSION



HAT CREEK PROJECT
FIGURE 3.3
DETAILED SITE LAYOUT MAP

SOURCE: British Columbia Hydro and Power Authority (1)



HAT CREEK PROJECT
FIGURE 3-4
PROJECT OVERVIEW FROM SOUTH EAST

SOURCE: Toby, Russell, Buckwalter and Partners Architects (2)



HAT CREEK PROJECT
FIGURE 3-5
POWERPLANT FROM WEST

SOURCE: Toby, Russell, Buckwell and Partners Architects (2)

| | | |
|-----|--|-------------|
| 4 | <u>GEOLOGY</u> | <u>Page</u> |
| 4.1 | Introduction | 1 |
| 4.2 | Exploration and Development | 2 |
| | 4.2.1 Geophysical and Geological Logging | 3 |
| | 4.2.2 Coal Sampling | 3 |
| 4.3 | Geology | 4 |
| | 4.3.1 Stratigraphy | 4 |
| | 4.3.2 Structure | 4 |
| | 4.3.3 Burn Zone | 5 |
| | 4.3.4 Trench Geology | 5 |
| 4.4 | Depositional Environment | 7 |
| 4.5 | Coal Quality | 8 |
| | 4.5.1 Ash and Heating Value | 8 |
| | 4.5.2 Moisture Determination | 9 |
| | 4.5.3 Sulphur Distribution | 10 |
| | 4.5.4 Mineral Analysis of Ash, Ash Fusibility, and Grindability | 11 |
| | 4.5.5 Specific Gravity | 11 |
| 4.6 | Coal Reserves | 13 |
| | 4.6.1 Introduction | 13 |
| | 4.6.2 Development of the Variable Block Model | 13 |
| | 4.6.2.1 Developing Reserve Blocks | 13 |
| | 4.6.2.2 Quality Assignment to Blocks | 14 |
| | 4.6.2.3 Application of the Variable Block Model | 15 |
| | 4.6.3 Reserves | 15 |
| 4.7 | Geostatistics | 16 |
| | 4.7.1 Preliminary Studies | 16 |
| | 4.7.2 Sulphur | 16 |
| | 4.7.3 Research Project | 17 |

| <u>No.</u> | <u>LIST OF TABLES</u> | <u>Page</u> |
|------------|--|-------------|
| 4-1 | Summary of Drilling | 18 |
| 4-2 | Regional Stratigraphy | 19 |
| 4-3 | Development of Stratigraphic Subdivision | 20 |
| 4-4 | Summary of Proximate and Ash Analyses | 21 |
| 4-5 | Sulphur Forms | 22 |
| 4-6 | Reserve Estimation by Sub-zones with 2 m Minimum Thickness | 23 |
| 4-7 | Reserve Estimation by Benches with 2 m Minimum Thickness | 24 |
| 4-8 | Reserve Estimation with Non-Selective Mining at 9.3 MJ/kg Cut-off | 25 |
| 4-9 | Reserve Estimation with Non-Selective Mining at 6.98 MJ/kg Cut-off | 26 |
| 4-10 | Total Sulphur Distribution in Sub-zones of No. 1 Deposit | 27 |
| 4-11 | Kriging Parameters | 28 |
| 4-12 | Sulphur Distribution in Sub-zone A5 | 29 |

LIST OF FIGURES

| | | |
|-----|--|----|
| 4-1 | Geophysical Log DH 274, showing the 16 sub-zones | 30 |
| 4-2 | Regional Bedrock Geology | 31 |
| 4-3 | Geological Cross-section Q | 32 |

LIST OF FIGURES (Continued)

Page

| | | |
|------|---|----|
| 4-4A | Geological Cross-section 18 N | 33 |
| 4-4B | Geological Cross-section 18 S | 34 |
| 4-5 | Ash-Heating Value Regression Curve (Ash <60%) | 35 |
| 4-6 | Sample Semi-Variogram, Sulphur - Sub-zone A2 | 36 |

SECTION 4

GEOLOGY

4.1

INTRODUCTION

This report summarizes all the geological, geophysical, and coal quality data for the No. 1 Deposit, based on a 152.4 m grid. Statistical studies for the various parameters show a high level of confidence, from which it is concluded that the geological data are adequate for mine planning.

To determine chemical properties of the coal deposits, proximate, ultimate, and ash analyses were made on the core samples at Commercial Testing Laboratories and General Testing in Vancouver, and Loring Laboratories in Calgary. In order to improve technical control and expedite analytical work, a field laboratory was set up for the 1977/78 exploration program to handle routine proximate analysis, thermal value determination, sulphur, and screen analysis. All sampling and analytical procedures followed American Society for Testing and Materials' (ASTM) standards.

Samples were also provided for washability studies at the laboratories of Energy, Mines and Resources in Edmonton, Birtley Engineering (Canada) Limited, and Warnock Hersey Professional Services Ltd., in Calgary. Warnock Hersey also conducted wet attrition tests to simulate size degradation in a washing plant and wet screen analyses of the low-grade coal for any possible beneficiation.

In the earlier stages of exploration, between 1925 and 1959, 22 diamond-drill holes aggregating 4,375.8 m were drilled. This indicated the potential of a large low-rank coal deposit in the Hat Creek Basin.

In 1974, B.C. Hydro initiated a detailed exploration program to define the limits, structure, and coal quality of the Hat Creek Basin.

Golder & Associates were retained as consultants for the geotechnical studies, including slope stability, foundation, and geo-hydrological investigation which formed an integral part of the overall program.

Till 1977, the geological drilling and exploration program was conducted by Dolmage Campbell and Associates. Subsequently, B.C. Hydro took over the responsibility of running the program. In the total program, 206 exploration holes (54,037 m), 151 geotechnical holes (7,996.7 m), and 117 holes (2,117.7 m) for surficial material investigation, bulk sampling, and other studies, aggregating 73,860.3 m, were drilled. (Table 4-1)

Under the same program, 64 holes (21,800 m) were drilled in the No. 2 Deposit South of the No. 1 Deposit. Though the reserves indicated were larger than those of the No. 1 Deposit, the mining and economic conditions were not as favourable. Consequently, no further drilling was considered at this time.

Regional surface geophysical surveys, especially gravity and magnetometer, have helped in delimiting the coal deposit and identifying the distribution of the denser materials - i.e. burnt zone rocks and volcanic rocks.

Aerial photographic surveys were carried out to provide topographic maps and control for exploration work. Elevation control was established by running third-order levels from the geodetic bench mark near the junction of Highways 12 and 97. Additional survey bench marks established by McElhanney in 1976 served as ground control in the area.

After drilling was completed, the drill sites were cleaned, levelled, and restored to the natural ground contours before seeding with a mixture developed for use in the Hat Creek region.

4.2.1

Geophysical and Geological Logging

All holes were geophysically logged (Gamma Ray and Density) on a scale of 1:250. Geologists provide data on the rate of penetration versus bit pressure and bit rpm versus pump pressure. Gamma ray and density log peaks were used to identify marker horizons and varying lithologies throughout most of the deposit, thus providing a means of sub-zone correlation between drill holes. Gamma ray log peaks essentially reflect claystone interbeds (partings) with relatively high radioactive K-ion content. The corresponding density log reflects the variation in density of the rock and coal or coaly material.

Five ranges of the API (American Petroleum Institute) values were established to represent coals of varying ash content and waste bands. These were plotted on cross sections to aid in the interpretation of the lithofacies distribution and structure of the deposit. Correlation of the data led to the concept of 16 sub-zones within the four major zones recognized earlier.

Cores obtained from drilling have been geologically logged; the lithological and structural characteristics, mineralization, etc., have also been recorded. All the cores have been indexed and preserved in core sheds at the site.

4.2.2

Coal Sampling

Systematic analytical work was conducted, applying a 6 m maximum sampling interval for proximates, thermal values, and sulphur determination; and 12 m - 18 m maximum for mineral-ash analyses, fusibility, grindability, and other tests. As a rule, the sampling intervals were required to correspond to the natural boundary of the homogeneous coal as reflected by the geophysical logs. The cores were split in half along their length and bagged for chemical tests. The other half were stored for future reference. Since 1977, all the samples were run at B.C. Hydro's laboratory located at the site. Check samples were regularly sent out to commercial laboratories.

4.3 GEOLOGY

4.3.1 Stratigraphy

The tertiary sediments in the Upper Hat Creek Valley were deposited in a Northerly-trending topographic depression in the South-West part of the Intermontane Belt of the Canadian Cordillera. The mountains bordering the valley range in age from Permian to Cretaceous. The valley floor is underlain by tills and glacio-fluvial deposits subsequent to the Pleistocene glaciation. Table 4-2 summarizes the general stratigraphy of the region.

The coal-bearing section belongs to the Hat Creek Formation of the Eocene Epoch deposited 36 to 42 million years ago. It is underlain by the Coldwater Formation consisting of detrital sediments and overlain by poorly consolidated bentonitic claystone and siltstone beds of the Medicine Creek Formation. These beds were subjected to glaciation and subsequently overlain by glacio-fluvial material.

Based on lithology, coal quality, and geophysics, the Hat Creek Coal Formation was sub-divided into 16 sub-zones. Two of these sub-zones, A-6 and C-1, are essentially waste and coaly shale units, while the remaining 14 represent coal of varying quality. Table 4-3 illustrates a scheme for the development of the stratigraphic sub-division of the Hat Creek Coal Formation.

A typical sub-division is illustrated in Figure 4-1.

4.3.2 Structure

The regional structure of the Hat Creek Coal Basin is a North-trending graben flanked on both sides by gravity faults. Transverse faults have offset the graben in places.

The primary structure in the No. 1 Deposit consists of two synclines separated by an anticline, plunging at an average of 15° to 17° towards the South-South-West. It is truncated on the South and East by steeply dipping boundary faults (Figure 4-2). Repetition of

Trench B: This exposed the D-zone coal, representing the earliest phase of thick coal deposition. It was marked by an abundance of petrified wood up to 12-15 m long. The coal was hard, compact, and massive, with a thin film of siderite and a cluster of very fine pyrite crystals along the fracture planes.

Trench C: Trench C excavation showed the sliding of the older Coldwater Formation over the younger glacial till. The failure of some of the faces indicates material weakness due to water seepage and swelling of the bentonitic claystone.

Some 40 million years ago, peat deposition began in a generally broad North-trending marsh with little or no circulating water. The favourable climatic conditions, aided by the slowly sinking basin throughout the period of D-zone deposition, accounts for the immense thickness of the virtually uninterrupted coal mass. When the equilibrium was disturbed by rapid sinking, the basin was cyclically flooded by fresh water, leading to the deposition of numerous partings in the coal measures following D-zone deposition. The Western and the South-Western margins of the peat basin received fluctuating amounts of coarse sediment, resulting in rapid lithofacies change from coal to coarse sandstone, particularly in rock member sub-zones A-6 and C-1 which thicken significantly towards the South and West. In the centre and North-East of the peat basin, the rates of subsidence and deposition were about equal, and the effect of the silty sediment from the Western stream was minimal, allowing the continued accumulation of plant debris to proceed uninterrupted.

The Interior Plateau region was affected by volcanic activity contemporaneous with the peat deposition. The widespread occurrence of ash beds in the coal measures reflects these episodes of volcanic eruptions.

COAL QUALITY

Systematic analytical work was conducted on all cores, applying a 6 m maximum sampling interval for proximates, heating values, and sulphur, and a 12 to 18 m maximum for mineral-ash analysis, fusibility, grindability, and other tests.

In 1977, 7,000 t of sample coal was transported to Battle River Powerplant in Alberta for technological evaluation of its burning characteristics. This program demonstrated that a typical Hat Creek coal can be handled, pulverized, and burned in a commercial powerplant.

Washability tests were performed on the above sample. Earlier studies on bulk-auger samples had indicated an imbalance in size consist due to excessive size degradation in the washing process affecting the actual recovery values. Subsequent wet attrition tests, at Warnock Hersey in Calgary, explained this anomaly.

4.5.1

Ash and Heating Value

The dry-ash vs. heating value MAF (Moisture Ash Free) regression analysis of the three holes, DH 135, 136, and 274, in the central part of the basin indicates a linear relationship for samples from the A, B, and C-zones with less than 60% ash (db). The plot for D-zone from the same holes shows an almost identical trend. This is indicative that the coals from various zones have the same rank. To establish a practical ash vs. heating value (db) regression line (Figure 4-5), and the analytical values (Table 4-4) for all the coals within the deposit with the exclusion of those below the cut-off grade, were included in the regression analysis.

The ultimate analysis is required to calculate the net heating value of the coal and to establish the emission levels of oxides of sulphur and nitrogen.

The average values for Hat Creek coal are:

C = 46.2
H = 3.6
O = 15.4
N = 0.9
Cl = 0.03
S = 0.51

4.5.2 Moisture Determination

One of the most critical parameters in coal analysis is the determination of "in-situ" moisture.

In the exploration stage, where heavy reliance is imposed on drill cores, it is not possible to get cores in their natural state because of the drilling-water contamination. To improve this situation, "equilibrium moisture" as per ASTM (1412-56) was determined. This tended to be higher than true "in-situ" moisture, as coal in nature is more compact and not always saturated to the optimum level that the ASTM calls for.

Tests run from 1957 to 1976 produced an average equilibrium moisture of 24.2%.

The 1978 5A Drilling Program incorporated a careful moisture analysis program. The sampling procedure involved the following steps:

- (1) Taking 10 cm samples every 15 m in coal;
- (2) Taking the sample immediately after it came out of the core barrel;
- (3) Wiping the surface moisture off with a rag;
- (4) Sealing the sample in plastic wrap and tape;
- (5) Resealing the sample in a plastic tube with the air squeezed out and the end heat-sealed.

The results for 121 samples showed an average total in-situ moisture of 21.86% (with a standard deviation of 4.14% and a standard error of the mean of 0.38%), average ash (db) 28.18%.

Moisture in coal is present in two forms: surface and bonded. The surface (or air-dried) moisture is readily lost when exposed to the atmosphere. The mean value obtained for 2,600 samples tested for air-dried moisture was 12.97% with a standard deviation of 5.73% and a standard error of the mean of 0.11%.

The residual or bonded moisture is determined by heating an air-dried sample for an hour at 110°C. Normally the coal will re-absorb this moisture when exposed to the atmosphere. The mean value of over 4,000 residual moisture tests was 9.06% with a standard deviation of 4.75% and a standard error of the mean of 0.07%.

Studies conducted by the Paul Weir Company have predicted a mean total moisture content for run-of-mine coal of 23.5%.

4.5.3 Sulphur Distribution

Initial studies on sulphur distribution in the No. 1 Deposit showed an average value of 0.51%, of which approximately 71% was organic, 25% pyritic and 4% sulphate.

Table 4-5 shows the distribution of the forms of sulphur by zone and for the whole deposit.

Recent studies indicate that the distribution is not as erratic as was thought earlier. In many sections within the sub-zones, continuity in sulphur distribution is observed. There are distinct bands in the sub-zones that contain a high sulphur concentration. High sulphur concentration has been identified in the top 3 m of A1 sub-zone coal and at the bottom of the B2 sub-zone. The identification of such sections will have a direct impact in controlling the sulphur content of the run-of-mine coal.

Some of the other broad conclusions are:

- (1) The Western sector of the deposit shows higher sulphur than the Eastern sector;

- (2) A-zone contains the highest average total sulphur, while B-zone contains the highest local concentrations.

Sulphur is discussed further in Section 4.7.2 on Geostatistics.

4.5.4 Mineral Analysis of Ash, Ash Fusibility and Grindability

The major constituents of the coal-ash average 52.6% SiO₂ and 28.3% Al₂O₃ may be of interest for alumina extraction. The analyses of ash from the four zones show no appreciable difference, indicating the source material for the ash remained unchanged throughout the coal deposition.

The ash deformation temperature is indicative of its physical behaviour at combustion temperatures. The range from initial deformation to fluid temperature suggests the fouling conditions of the boiler.

The average initial deformation temperature, taken over the entire deposit, is in excess of 1,400°C, the limit of most of the laboratory furnaces.

The Hardgrove Grindability Index for D-zone is lower than the A, B, and C-zone coal. The normal range of HG Index falls between 38 and 50.

4.5.5 Specific Gravity

The specific gravity of coal was determined on small pieces of coal cores by the water displacement method after the sample had been fully saturated with water. As there was no significant difference between the specific gravities of coal from different zones for a given ash value, one common regression curve was developed:

$$\text{Specific Gravity} = 1.21104 + 0.00738 \times \text{Ash\%}$$

The average of 1,584 waste samples gave a specific gravity of 1.93. For calculation purposes a specific gravity of 2.00 was considered as more conservative.

The burn zone material averaged 2.16.

These values were used in reserve estimation.

4.6 COAL RESERVES

4.6.1 Introduction

The coal reserves for the Hat Creek No. 1 Deposit were calculated using a computer model. The selection of the modelling technique was controlled by the necessity to accurately reflect the complex structure, and to handle the variability of the coal density and quality. Other important criteria were: the ability to produce adequate displays for verifying and using the model; the ease of making changes for the addition of new data or for correcting errors; and the flexibility to adapt to changing requirements.

The technique selected was to construct a cross-sectional model using the Variable Block Model (VBM) method developed by Mintec Inc. Using this method makes it possible to produce a model that accurately duplicates the geologist's interpretation on each section with assigned quality values for each block.

4.6.2 Development of the Variable Block Model

4.6.2.1 Developing Reserve Blocks

The geological zones and structural features were digitized from cross-sections using an electronic digitizer. Cross-sections were then plotted by the computer on the same scale as the originals for checking.

On each cross-section the sub-zones were sub-divided by faults and further sub-divided equally into smaller blocks less than 200 m in horizontal length.

The top and bottom surfaces of each block coincide with the sub-zone boundaries, which produces a block of variable thickness conforming to the geological interpretation. Each block is projected halfway to the adjoining cross-sections: 76.2 m North and South.

When the block definition process is completed the data is stored in the "Geometry File".

4.6.2.2

Quality Assignment to Blocks

Composite sample values were calculated for each sub-zone in each drill hole. The individual samples were weighted by their length and specific gravity. The composite values were computed in two different ways. The first method combines all the samples, both coal and waste, for a given sub-zone and drill hole, which effectively assigns the whole intersection to either coal or waste at a given cut-off grade. This method represents non-selective mining. In the second method, the coal and waste samples were accumulated separately provided that they formed part of a band greater than 2 m in thickness, which reflects selective mining capability. Bands less than 2 m thick were combined with the adjacent samples. The split between coal and waste was defined by an assigned cut-off grade. Using the second method generated additional data for storage: coal thickness, waste thickness and the number of coal/waste contacts.

Quality values were calculated for each block using the inverse square of the distance method applied to the distance between the block centre and the mid-point of the composite sample used. The search distance used was 175 m North-South and 500 m East-West. If the closest composite contained no coal, then none was assumed to exist within the block. In the interpolation of blocks using the selective mining method the volumes of coal and waste in the block were estimated in proportion to the ratio of coal to waste thickness.

Blocks outside the search distance were classified as "undefined" and no quality values were assigned. Undefined materials were assumed to be waste in the A6 and C1 sub-zones and to be coal in the remaining sub-zones. The undefined coal is considered to be in the category of "Possible Reserves".

The specific gravity of coal was calculated from the formula:

$$\text{S.G.} = 1.211 + 0.00738 (\% \text{ dry-ash}).$$

Burn zone material was assigned a specific gravity of 2.16, and other waste 2.00 (see Section 5.2.5.2).

These factors were used in developing the composite sample values and in reserve calculations. In the "undefined" coal blocks calculations were based on the average specific gravity for the sub-zone.

Block values can be calculated for either the selective or non-selective mining cases and for different cut-off grades. Each set of block values is stored in its own "Quality File". In this study four "Quality Files" were prepared: for both mining cases each at two different cut-off grades - 9.3 MJ/kg and 6.98 MJ/kg.

4.6.2.3 Application of the Variable Block Model

The "Geometry" and "Quality" files can then be used for calculating the reserves within a designed pit or for the total deposit.

4.6.3 Reserves

1. Selective Mining

The proven and probable coal reserves of the Hat Creek No. 1 Deposit have been computed to be 739,523 million tonnes with a heating value of 17.71 MJ/kg, ash content 34.82% and sulphur content of 0.51%. The possible reserves are an additional 45 million tonnes.

These figures are for the proposed mining method of selective mining with removal of 2-m partings and a cut-off value of 9.3 MJ/kg. Table 4-6 and Table 4-7 show the distribution of the reserves by sub-zones and by 100-m bench elevations.

2. Non-selective Mining

If no waste parting removal is considered, then the reserves of the No. 1 Deposit based on a cut-off value of 9.3 MJ/kg would be (as shown in Table 4-8) 746,058 million tonnes coal at 16.72 MJ/kg, 37.73% ash, and 0.46% sulphur.

Table 4-9 illustrates what the coal reserves would be if the cut-off value was lowered to 6.98 MJ/kg.

4.7 GEOSTATISTICS

4.7.1 Preliminary Studies

The objectives of a geostatistical study is to measure the degree of continuity in a parameter (e.g. heating value, sulphur) throughout the deposit. With a knowledge of the degree of continuity, block values may be developed and an estimate made of the error of estimation.

Preliminary studies were assigned to Mineral Exploration Research Institute (IREM-MERI) to investigate the spatial distribution of heating value and sulphur.

An initial study of 14 sub-zones showed good continuity of heating value in the coal zones. The Inverse Square Distance Method (ISD) approximates the good continuity which was found to exist in the coal zones.

4.7.2 Sulphur

Initial studies of sulphur variation indicated poor continuity. However, many additional sulphur values were determined and incorporated in a geostatistical study of the total sulphur distribution in the deposit. Variograms were developed for each sub-zone and reviewed with IREM-MERI. With the additional data, good variograms, which indicate continuity and predictability, were obtained for 10 of the 16 sub-zones. The remaining six sub-zones showed random sulphur distribution.

Figure 4-6 presents a sample variogram.

The results of the variogram calculations are summarized in Table 4-10.

The parameters shown in Table 4-11 were used to produce estimates of the sulphur content of all the blocks contained within each sub-zone by kriging. The kriged block values were input to the Variable Block Model for use in reserve and pit evaluation calculations.

Table 4-12 shows a sample of the results obtained from kriging the block sulphur values in a portion of the A5 sub-zone. Two important conclusions are drawn from this table:

- (1) The standard error of the individual blocks does not substantially deviate from the average value of 0.081;
- (2) A large number of intersections were found to krig each block.

This indicates that in the A5 sub-zone, where sufficient data has been gathered, a confidence interval of 10% can be expected for the block mean at a 68% (1 S.D.) precision level. Individual blocks will vary up or down from this figure.

Additional tests indicated a 12% confidence interval for the two B sub-zones at a 68% precision level and a 20% confidence interval for D1, D2, and D4. The impact of the lower precision in D-zone is small because of the low average sulphur content. It must be emphasized that the previous precision figures do not apply to the six sub-zones that exhibited random behaviour. The distribution of these six sub-zones are predicted by classical statistics and shown on Table 4-10.

The precision figures were calculated for 75 m x 75 m blocks. During the mining phase, the confidence interval will be improved by:

- (1) Drilling to test the quality distribution ahead of mining on a smaller spacing than the present 150 m x 150 m grid, to increase the number of samples and hence the confidence interval;
- (2) Coal from several locations is mixed in the blending pile, which further reduces the sulphur variation.

4.7.3 Research Project

A research project was undertaken by IREM-MERI to investigate the applicability of a three-dimensional method to estimate heating value in 75 m x 75 m x 15 m bench blocks. Following three months of theoretical research, a new method to estimate grades in sedimentary deposits was developed. A series of computer programs have been developed to produce a model of the deposit using the new method. Careful checking and verification of the results is still required before the system is ready for application.

TABLE 4-1

SUMMARY OF DRILLING
UPPER HAT CREEK VALLEY
1925 - 1978

| | <u>No. 1 Deposit</u> | | <u>No. 2 Deposit</u> | |
|--|----------------------|-----------------|----------------------|-----------------|
| | <u>No. of Holes</u> | <u>Meters</u> | <u>No. of Holes</u> | <u>Meters</u> |
| 1. Exploration: Pre-1974 | 22 | 4,375.8 | 64 | 21,799.9 |
| 1974-1978 | 206 | 54,037.0 | | |
| 2. Geotechnical: (slope stability foundation incl.) | 74 | 9,714.9 | | |
| (Geohydrological and offsite) | 77 | 7,996.7 | | |
| 3. Miscellaneous: Surficial Material Investigation, | | | | |
| Washability BAH) | | | | |
| Sampling, etc. AH) 117 | | 2,117.7 | | |
| P) | | | | |
| TOTAL | 474 | 78,236.1 | 64 | 21,799.9 |

DH - Diamond Drilling
RH - Rotary
BAH - Bucket Auger Hole
AH - Auger Hole
P - Percussion

Table 4-2

REGIONAL STRATIGRAPHY - HAT CREEK COAL BASIN

| Period | Epoch | Million Years | Formation or Group | Thickness (m) | Rock Types | | |
|---|---|---------------|---------------------------------------|--------------------------|--|--|---|
| Quaternary | Recent | | | Not Determined | Alluvium, Colluvium, fluvial sands and gravels, slide debris, lacustrine sediments. | | |
| | Pleistocene | 1.5 - 2 | | | Glacial till, glacio-lacustrine silt, glacio-fluvial sands and gravels, land slides. | | |
| Unconformity | | | | | | | |
| Tertiary | Miocene | 7 - 26 | Plateau Basalts | Not Determined | Basalt, olivine basalt (13.2 m.y.), andesite, vesicular basalt. | | |
| | Unconformity (?) | | | | | | |
| | Miocene or Middle Eocene ? | | Kamloops Group | Finney Lake Formation | Not Determined | Lahar, sandstone, conglomerate. | |
| | Unconformity | | | | | | |
| | Late Eocene | | | Medicine Creek Formation | 600+ | Bentonitic claystone and siltstone. | |
| | Paraconformity | | | | | | |
| | Late Eocene to Middle Eocene | * 36 - 42 | | Hat Creek Coal Formation | 550 | Mainly coal with intercalated siltstone, claystone, sandstone and conglomerate. | |
| | | | | Coldwater Formation | 375 | Siltstone, claystone, sandstone, conglomerate, minor coal. | |
| | Fault Contact or Nonconformity | | | | | | |
| | Middle Eocene | 43.6-49.9 | | | | Not Determined | Rhyolite, dacite, andesite, basalt and equivalent pyroclastics. |
| Unconformity (McKay 1925; Duffell & McTaggart 1952) | | | | | | | |
| Cretaceous or Later | Coniacian to Aptian ** | 88.3±3 m.y. | | Spences Bridge Group | Not Determined | Andesite, dacite, basalt, rhyolite; tuff breccias, agglomerate. | |
| | Erosional Unconformity (Duffell & McTaggart 1952) | | | | | | |
| | | 98 | Mount Martley Stock | Not Determined | Granodiorite, tonallite. | | |
| Intrusive Contact (Duffell & McTaggart 1952) | | | | | | | |
| Pennsylvanian to Permian or earlier | | 250-330 | Cache Creek Group: | Not Determined | Marble, limestone, argillite | | |
| | | | Marble Canyon Formation Greenstone | | Not Determined | Greenstone, chert, argillite; minor limestone and quartzite, chlorite schist, quartz-mica, schist. | |

* Based on palynology by Rouse 1977

** Based on plant fossils by Duffell & McTaggart 1952.

Table 4-3

DEVELOPMENT OF STRATIGRAPHIC SUBDIVISION IN HAT CREEK COAL FORMATION

| STAGE I | STAGE II | STAGE III | STAGE IV |
|---|---|--|---|
| A | A ₁ | A ₁₋₁ | A1 |
| | | A ₁₋₂ | A2 |
| | | A ₁₋₃ | A3 |
| | | A ₁₋₄ | A4 |
| | A ₂ (waste zone) | A ₂₋₁ | A5 |
| B | B ₁ | B ₁₋₁ | A6 |
| | | B ₁₋₂ | B1 |
| | | | B2 |
| C | C ₁ (waste zone) | C ₁₋₁ | C1 |
| | | C ₂₋₁ | C2 |
| | C ₂ | C ₂₋₂ | C3 |
| | | | C4 |
| D | D ₁ | D ₁₋₁ | D1 |
| | | D ₁₋₂ | D2 |
| | | D ₁₋₃ | D3 |
| | | D ₁₋₄ | D4 |
| Recognition of four broad zones in the No. 1 Deposit. | Identification of two waste zones - A ₂ and C ₁ . | <p>A₁ - divided into four sub-zones separated by three waste partings.</p> <p>B₁ - divided into two sub-zones.</p> <p>C₂ - divided into two sub-zones separated by a lenticular waste parting.</p> <p>D₁ - divided into four sub-zones of varying quality.</p> | <p>For uniformity and convenience each subzone was assigned its own suffix. Thus A₂₋₁ and C₁₋₁ the principle waste zones are represented by A6 and C1 respectively.</p> <p>Four additional subzones were introduced: A5, C2, C3 and C4.</p> |

TABLE 4-4

SUMMARY OF PROXIMATE AND ASH ANALYSES

EXCLUDING SAMPLES WITH HHV < 9304 KJ/KG & ASH > 70.00%

PROXIMATE, MOISTURE AND OTHER SUMMARY

| | | HHV | % | % | % | % | % MOISTURES | | | | % | %ALK. | WATER SOLUBLE | | | |
|-----------------------|--|---------|-------|-------|-------|-------|-------------|-------|-------|-------|-------|--------|---------------|-------|-------|-------|
| | | (KJ/KG) | ASH | F.C. | V.M. | S | AS | AIR | RES- | DRY | RES- | EQUIL. | CO2 | AS | % | % |
| | | ***** | ***** | ***** | ***** | ***** | ***** | ***** | ***** | ***** | ***** | ***** | ***** | ***** | ***** | ***** |
| MAXIMUM | | 27398 | 62.18 | 72.83 | 46.61 | 5.54 | 36.92 | 31.56 | 22.35 | 35.60 | 15.60 | 1.57 | .35 | .60 | | |
| MINIMUM | | 9317 | 7.96 | 7.56 | .63 | .03 | 2.26 | .44 | .22 | 16.76 | .02 | .08 | .15 | .01 | | |
| RANGE | | 18081 | 54.22 | 65.27 | 45.98 | 5.51 | 34.66 | 31.12 | 22.13 | 18.84 | 15.58 | 1.49 | .20 | .59 | | |
| WEIGHTED MEAN | | 18443 | 32.56 | 33.96 | 34.37 | .55 | 22.54 | 12.93 | 8.90 | 23.83 | 1.42 | .51 | .26 | .07 | | |
| SAMPLE COUNTS | | 4028 | 4028 | 1375 | 1375 | 4026 | 1793 | 1792 | 4027 | 34 | 1445 | 951 | 18 | 19 | | |
| SAMPLE CORE LENGTHS | | 15384 | 15384 | 7101 | 7101 | 15374 | 9276 | 9275 | 15383 | 239 | 6935 | 4418 | 54 | 58 | | |
| ARITHMETIC MEAN | | 18037 | 33.76 | 33.54 | 33.90 | .57 | 22.44 | 12.96 | 7.94 | 23.82 | 1.48 | .51 | .25 | .05 | | |
| SAMPLE COUNTS | | 4028 | 4028 | 1375 | 1375 | 4026 | 1793 | 1792 | 4027 | 34 | 1445 | 951 | 18 | 19 | | |
| SAMPLE CORE LENGTHS | | 15384 | 15384 | 7101 | 7101 | 15374 | 9276 | 9275 | 15383 | 239 | 6935 | 4418 | 54 | 58 | | |
| STANDARD DEVIATION | | 4456 | 12.94 | 8.79 | 5.35 | .37 | 4.51 | 5.33 | 4.15 | 4.70 | 2.00 | .24 | .05 | .13 | | |
| COEFF. OF VARIATION % | | 24.70 | 38.32 | 26.21 | 15.79 | 66.21 | 20.12 | 41.18 | 52.28 | 19.74 | 35.12 | 47.95 | 21.87 | 25.75 | | |

MINERAL SUMMARY - XDRY ASH

| | | % | % | % | % | % | % | % | % | % | % | % | % | % | UNDET |
|-----------------------|--|-------|-------|-------|-------|-------|-------|-------|-------|-------|-------|-------|-------|-------|-------|
| | | SI02 | AL2O3 | TI02 | FE2O3 | CAO | MGO | NA2O | K2O | MN3O4 | V2O5 | P2O5 | S03 | +ERR | |
| | | ***** | ***** | ***** | ***** | ***** | ***** | ***** | ***** | ***** | ***** | ***** | ***** | ***** | ***** |
| MAXIMUM | | 77.16 | 40.19 | 1.85 | 56.00 | 47.08 | 8.07 | 5.42 | 1.80 | 1.94 | .49 | 6.14 | 7.64 | 7.57 | |
| MINIMUM | | 17.06 | 9.26 | .04 | .10 | .33 | .00 | .17 | .00 | .00 | .00 | .00 | .04 | -1.56 | |
| RANGE | | 60.10 | 30.93 | 1.81 | 55.90 | 46.75 | 8.07 | 5.25 | 1.80 | 1.94 | .49 | 6.14 | 7.60 | 9.13 | |
| WEIGHTED MEAN | | 52.39 | 27.53 | .94 | 8.40 | 3.55 | 1.57 | 1.40 | .49 | .17 | .06 | .42 | 2.08 | .99 | |
| SAMPLE COUNTS | | 913 | 913 | 913 | 913 | 913 | 913 | 951 | 951 | 913 | 913 | 913 | 913 | 913 | |
| SAMPLE CORE LENGTHS | | 4159 | 4159 | 4159 | 4159 | 4159 | 4159 | 4418 | 4418 | 4159 | 4159 | 4159 | 4159 | 4159 | |
| ARITHMETIC MEAN | | 52.29 | 27.96 | .91 | 8.34 | 3.46 | 1.57 | 1.35 | .51 | .16 | .05 | .38 | 1.98 | .96 | |
| SAMPLE COUNTS | | 913 | 913 | 913 | 913 | 913 | 913 | 951 | 951 | 913 | 913 | 913 | 913 | 913 | |
| SAMPLE CORE LENGTHS | | 4159 | 4159 | 4159 | 4159 | 4159 | 4159 | 4418 | 4418 | 4159 | 4159 | 4159 | 4159 | 4159 | |
| STANDARD DEVIATION | | 7.29 | 5.10 | .28 | 6.35 | 3.72 | .76 | .79 | .30 | .22 | .04 | .61 | 1.22 | 1.04 | |
| COEFF. OF VARIATION % | | 13.95 | 18.25 | 31.49 | 76.15 | 7.43 | 48.52 | 59.04 | 58.42 | 35.18 | 71.02 | 58.68 | 61.72 | 7.91 | |

TABLE 4-5

SULPHUR FORMS

| | <u>Zone A</u> | <u>Zone B</u> | <u>Zone C</u> | <u>Zone D</u> | <u>Deposit Total</u> |
|------------------------|---------------|---------------|---------------|---------------|--------------------------|
| Pyritic Sulphur % | 0.22 | 0.20 | 0.11 | 0.04 | 0.13 |
| Organic Sulphur % | 0.50 | 0.44 | 0.31 | 0.24 | 0.36 |
| Sulphur as Sulphates % | <u>0.02</u> | <u>0.03</u> | <u>0.01</u> | <u>0.02</u> | <u>0.02</u> |
| Total | 0.74 | 0.67 | 0.43 | 0.30 | 0.51 |

TABLE 4-6

RESERVE ESTIMATION BY SUB-ZONES WITH 2 m MINIMUM THICKNESS

* HHV CUT-OFF 9.30 * NO DILUTION * 2-METRE MIN. THICKNESS *

DATE : 27-Mar-79

| ZONE | COAL | ASH% | HHV | SUL% | TOTAL | COAL | WASTE | UNDEF TONNES | | UNDEF VOLUME | |
|-------|---------|-------|-------|------|---------|---------|---------|--------------|--------|--------------|--------|
| | TONNES | | MJ/KG | | VOLUME | VOLUME | TONNES | COAL | WASTE | COAL | WASTE |
| BURN | 0. | 0.00 | 0.00 | 0.00 | 6769. | 0. | 14620. | 0. | 0. | 0. | 0. |
| A1 | 27223. | 31.18 | 18.74 | 0.75 | 28365. | 18905. | 18921. | 0. | 0. | 0. | 0. |
| A2 | 41408. | 39.60 | 15.88 | 0.77 | 40524. | 27566. | 25915. | 0. | 0. | 0. | 0. |
| A3 | 35944. | 45.50 | 13.96 | 0.65 | 41833. | 23244. | 37178. | 0. | 0. | 0. | 0. |
| A4 | 49558. | 40.75 | 15.58 | 0.66 | 57099. | 32794. | 48611. | 0. | 0. | 0. | 0. |
| A5 | 58665. | 44.42 | 14.47 | 0.74 | 56168. | 38139. | 36056. | 0. | 0. | 0. | 0. |
| A6 | 7041. | 50.48 | 12.32 | 0.63 | 65940. | 4450. | 122745. | 0. | 235. | 0. | 117. |
| B1 | 72681. | 38.06 | 16.55 | 0.65 | 56301. | 48816. | 14317. | 488. | 0. | 327. | 0. |
| B2 | 60561. | 37.78 | 16.66 | 0.71 | 63751. | 46075. | 33836. | 1129. | 0. | 758. | 0. |
| C1 | 10245. | 48.83 | 12.89 | 0.54 | 160095. | 6527. | 286629. | 0. | 20507. | 0. | 10253. |
| C2 | 19842. | 47.06 | 13.37 | 0.51 | 24326. | 12740. | 22515. | 512. | 0. | 328. | 0. |
| C3 | 20058. | 46.09 | 13.77 | 0.36 | 23116. | 12940. | 17272. | 2388. | 0. | 1540. | 0. |
| C4 | 32405. | 45.01 | 13.90 | 0.35 | 31660. | 21013. | 18457. | 2188. | 0. | 1418. | 0. |
| D1 | 70005. | 31.35 | 18.82 | 0.29 | 56075. | 48594. | 4150. | 7799. | 0. | 5407. | 0. |
| D2 | 89306. | 25.18 | 21.09 | 0.27 | 70872. | 64010. | 0. | 9585. | 0. | 6862. | 0. |
| D3 | 70476. | 19.70 | 23.08 | 0.29 | 59822. | 51984. | 389. | 10367. | 0. | 7643. | 0. |
| D4 | 66106. | 24.84 | 21.50 | 0.38 | 55313. | 47436. | 668. | 10518. | 0. | 7543. | 0. |
| TOTAL | 739523. | 34.82 | 17.71 | 0.51 | 898027. | 505233. | 702279. | 44973. | 20742. | 31825. | 10371. |

NOTE: 1. TONNAGES ARE THOUSANDS OF METRIC TONNES
2. VOLUMES ARE THOUSANDS OF CUBIC METRES

TABLE 4-7

RESERVE ESTIMATION BY BENCHES WITH 2 m MINIMUM THICKNESS

* HHV CUT-OFF 9.30 * NO DILUTION * 2-METRE MIN. THICKNESS *

DATE : 27-Mar-79

SUMMARY FOR ALL BENCHES :

4 - 24

| BENCH | COAL TONNES | ASHZ | HHV MJ/KG | SULZ | TOTAL VOLUME | COAL VOLUME | WASTE TONNES | UNDEF TONNES COAL | UNDEF TONNES WASTE | UNDEF VOLUME COAL | UNDEF VOLUME WASTE |
|-----------|----------------|-------|--------------|------|-----------------|----------------|-----------------|----------------------|-----------------------|----------------------|-----------------------|
| 1 (1200) | 0. | 0.00 | 0.00 | 0.00 | 0. | 0. | 0. | 0. | 0. | 0. | 0. |
| 2 (1100) | 235. | 35.08 | 17.80 | 0.42 | 1489. | 161. | 2657. | 0. | 0. | 0. | 0. |
| 3 (1000) | 40344. | 40.41 | 15.64 | 0.56 | 79369. | 26791. | 105050. | 341. | 0. | 244. | 0. |
| 4 (900) | 183099. | 34.81 | 17.56 | 0.54 | 194776. | 125031. | 135066. | 3476. | 227. | 2443. | 114. |
| 5 (800) | 209334. | 33.47 | 18.15 | 0.51 | 206531. | 143973. | 122767. | 1632. | 8. | 1177. | 4. |
| 6 (700) | 139151. | 34.87 | 17.76 | 0.53 | 156375. | 95061. | 120642. | 1373. | 0. | 994. | 0. |
| 7 (600) | 90910. | 35.82 | 17.50 | 0.50 | 118810. | 61816. | 110798. | 2116. | 134. | 1528. | 67. |
| 8 (500) | 53480. | 35.75 | 17.57 | 0.41 | 80907. | 36400. | 77968. | 5791. | 2821. | 4113. | 1410. |
| 9 (400) | 21455. | 30.64 | 19.52 | 0.33 | 44104. | 14982. | 26946. | 12713. | 13578. | 8859. | 6789. |
| 10 (300) | 1514. | 37.50 | 17.16 | 0.34 | 15666. | 1019. | 386. | 17530. | 3974. | 12467. | 1987. |
| 11 (200) | 0. | 0.00 | 0.00 | 0.00 | 0. | 0. | 0. | 0. | 0. | 0. | 0. |
| TOTAL | 739523. | 34.82 | 17.71 | 0.51 | 898027. | 505233. | 702279. | 44973. | 20742. | 31825. | 10371. |

TABLE 4-8

RESERVE ESTIMATION WITH NON-SELECTIVE MINING AT 9.3 MJ/kg CUT-OFF

* HHV CUT-OFF 9.30 * NO DILUTION * NO MINIMUM THICKNESS *

DATE : 30-Mar-79

4 - 25

| ZONE | COAL TONNES | ASH% ASH% | HHV MJ/KG | SUL% SUL% | TOTAL VOLUME | COAL VOLUME | WASTE TONNES | UNDEF TONNES COAL | UNDEF TONNES WASTE | UNDEF VOLUME COAL | UNDEF VOLUME WASTE |
|-------|----------------|--------------|--------------|--------------|-----------------|----------------|-----------------|----------------------|-----------------------|----------------------|-----------------------|
| BURN | 0. | 0.00 | 0.00 | 0.00 | 6769. | 0. | 14620. | 0. | 0. | 0. | 0. |
| A1 | 43219. | 48.17 | 13.04 | 0.53 | 28365. | 27637. | 1455. | 0. | 0. | 0. | 0. |
| A2 | 38078. | 46.08 | 13.78 | 0.63 | 40524. | 24600. | 31848. | 0. | 0. | 0. | 0. |
| A3 | 32392. | 54.60 | 10.94 | 0.53 | 41833. | 20076. | 43515. | 0. | 0. | 0. | 0. |
| A4 | 46830. | 49.40 | 12.85 | 0.54 | 57099. | 29744. | 54710. | 0. | 0. | 0. | 0. |
| A5 | 60364. | 49.93 | 12.68 | 0.64 | 56168. | 38239. | 35858. | 0. | 0. | 0. | 0. |
| A6 | 1839. | 50.21 | 12.46 | 0.44 | 65940. | 1164. | 129317. | 0. | 235. | 0. | 117. |
| B1 | 69475. | 36.91 | 16.83 | 0.64 | 56301. | 46917. | 18116. | 485. | 0. | 327. | 0. |
| B2 | 66861. | 38.89 | 16.25 | 0.67 | 63751. | 44716. | 36553. | 1135. | 0. | 750. | 0. |
| C1 | 9043. | 51.45 | 12.33 | 0.49 | 160095. | 5692. | 288300. | 0. | 20507. | 0. | 10253. |
| C2 | 23876. | 49.10 | 12.65 | 0.52 | 24326. | 15185. | 17624. | 517. | 0. | 328. | 0. |
| C3 | 20766. | 48.58 | 12.75 | 0.34 | 23116. | 13244. | 16665. | 2416. | 0. | 1540. | 0. |
| C4 | 32922. | 46.72 | 13.24 | 0.34 | 31660. | 21182. | 18120. | 2204. | 0. | 1418. | 0. |
| D1 | 73542. | 32.99 | 18.27 | 0.28 | 56075. | 50669. | 0. | 7864. | 0. | 5407. | 0. |
| D2 | 89306. | 25.18 | 21.09 | 0.27 | 70872. | 64010. | 0. | 9585. | 0. | 6862. | 0. |
| D3 | 70852. | 20.02 | 22.92 | 0.29 | 59822. | 52179. | 0. | 10385. | 0. | 7643. | 0. |
| D4 | 66693. | 25.20 | 21.35 | 0.38 | 55313. | 47769. | 0. | 10537. | 0. | 7543. | 0. |
| TOTAL | 746058. | 37.73 | 16.72 | 0.46 | 898027. | 503022. | 706701. | 45130. | 20742. | 31825. | 10371. |

NOTE: 1. TONNAGES ARE THOUSANDS OF METRIC TONNES
2. VOLUMES ARE THOUSANDS OF CUBIC METRES

TABLE 4-9

RESERVE ESTIMATION WITH NON-SELECTIVE MINING AT 6.98 MJ/kg CUT-OFF

* HHV CUT-OFF 6.98(3000RTUS) * NO DILUTION * NO MINIMUM THICKNESS *

DATE : 30-Mar-79

4 - 26

| ZONE | COAL TONNES | ASH% | HHV MJ/KG | SUL% | TOTAL VOLUME | COAL VOLUME | WASTE TONNES | UNDEF COAL | TONNES WASTE | UNDEF COAL | VOLUME WASTE |
|-------|----------------|-------|--------------|------|-----------------|----------------|-----------------|---------------|-----------------|---------------|-----------------|
| BURN | 0. | 0.00 | 0.00 | 0.00 | 6769. | 0. | 14620. | 0. | 0. | 0. | 0. |
| A1 | 44284. | 47.83 | 12.94 | 0.53 | 28365. | 28365. | 0. | 0. | 0. | 0. | 0. |
| A2 | 46623. | 49.68 | 12.68 | 0.59 | 40524. | 29638. | 21772. | 0. | 0. | 0. | 0. |
| A3 | 51223. | 57.51 | 9.98 | 0.48 | 41833. | 31339. | 20988. | 0. | 0. | 0. | 0. |
| A4 | 62286. | 53.28 | 11.63 | 0.49 | 57099. | 38885. | 36429. | 0. | 0. | 0. | 0. |
| A5 | 74965. | 52.68 | 11.79 | 0.60 | 56168. | 46911. | 18513. | 0. | 0. | 0. | 0. |
| A6 | 3060. | 58.15 | 10.65 | 0.36 | 65940. | 1870. | 127903. | 0. | 235. | 0. | 117. |
| B1 | 82809. | 41.13 | 15.48 | 0.60 | 56301. | 54868. | 2212. | 495. | 0. | 327. | 0. |
| B2 | 76557. | 42.01 | 15.24 | 0.66 | 63751. | 50489. | 25007. | 1153. | 0. | 758. | 0. |
| C1 | 14528. | 55.61 | 10.80 | 0.52 | 160095. | 8972. | 281740. | 0. | 20507. | 0. | 10253. |
| C2 | 31374. | 52.45 | 11.56 | 0.48 | 24326. | 19658. | 8679. | 525. | 0. | 328. | 0. |
| C3 | 28250. | 52.04 | 11.63 | 0.32 | 23116. | 17737. | 7679. | 2456. | 0. | 1540. | 0. |
| C4 | 40558. | 49.54 | 12.31 | 0.32 | 31660. | 25765. | 8953. | 2236. | 0. | 1418. | 0. |
| D1 | 73542. | 32.99 | 18.27 | 0.28 | 56075. | 50669. | 0. | 7864. | 0. | 5407. | 0. |
| D2 | 89306. | 25.18 | 21.09 | 0.27 | 70872. | 64010. | 0. | 9585. | 0. | 6862. | 0. |
| D3 | 70852. | 20.02 | 22.92 | 0.29 | 59822. | 52179. | 0. | 10385. | 0. | 7643. | 0. |
| D4 | 66693. | 25.20 | 21.35 | 0.38 | 55313. | 47769. | 0. | 10537. | 0. | 7543. | 0. |
| TOTAL | 856909. | 41.03 | 15.62 | 0.45 | 898027. | 569124. | 574497. | 45235. | 20742. | 31825. | 10371. |

NOTE: 1. TONNAGES ARE THOUSANDS OF METRIC TONNES
2. VOLUMES ARE THOUSANDS OF CUBIC METRES

TABLE 4-10

TOTAL SULPHUR DISTRIBUTION IN SUB-ZONES
OF NO. 1 DEPOSIT

| <u>Sub-zone</u> | <u>Number of Inter-sections</u> | <u>Mean Sulphur %</u> | <u>Standard Deviation</u> | <u>Standard Error of the Mean</u> |
|-----------------|---------------------------------|-----------------------|---------------------------|-----------------------------------|
| A1 | 32 | 0.723 | 0.193 | 0.034 |
| A2 | 38 | 0.804 | 0.174 | 0.028 |
| A3 | 42 | 0.634 | 0.137 | 0.021 |
| A4 | 48 | 0.624 | 0.165 | 0.024 |
| A5 | 54 | 0.739 | 0.187 | 0.025 |
| *A6 | - | 0.540 | 0.169 | 0.027 |
| B1 | 53 | 0.640 | 0.210 | 0.029 |
| B2 | 57 | 0.664 | 0.174 | 0.023 |
| *C1 | - | 0.450 | 0.300 | 0.051 |
| *C2 | 55 | 0.486 | 0.209 | 0.028 |
| *C3 | 56 | 0.356 | 0.213 | 0.028 |
| *C4 | 67 | 0.369 | 0.266 | 0.032 |
| D1 | 74 | 0.323 | 0.192 | 0.022 |
| D2 | 77 | 0.260 | 0.096 | 0.011 |
| *D3 | 84 | 0.298 | 0.0987 | 0.011 |
| D4 | 86 | 0.388 | 0.102 | 0.011 |

* These sub-zones exhibit random distribution in the variograms.

TABLE 4-11

KRIGING PARAMETERS

| <u>Zone</u> | <u>Co</u> | <u>Sill</u> | <u>Range</u> | <u>Angle of Anisotropy</u> | <u>Anisotropic Ratio</u> |
|-------------|-----------|-------------|--------------|----------------------------|--------------------------|
| A1 | 0.0100 | 0.0376 | 300 | - | - |
| A2 | 0.0025 | 0.0300 | 390 | 90 | 2.5 |
| A3 | 0.0032 | 0.0120 | 400 | 90 | 2 |
| A4 | 0.0050 | 0.0265 | 600 | 90 | 3 |
| A5 | 0.0110 | 0.0348 | 600 | - | - |
| A6 | - | - | - | - | - |
| B1 | 0.0260 | 0.0415 | 500 | - | - |
| B2 | 0.0100 | 0.0257 | 500 | 90 | 2 |
| C1 | - | - | - | - | - |
| *C2 | 0.0437 | 0.0437 | 50 | - | - |
| *C3 | 0.0454 | 0.0454 | 50 | - | - |
| *C4 | 0.0780 | 0.0780 | 50 | - | - |
| D1 | 0.0060 | 0.0300 | 540 | - | - |
| D2 | 0.0008 | 0.0074 | 400 | - | - |
| *D3 | 0.0060 | 0.0060 | 50 | - | - |
| D4 | 0.0020 | 0.0100 | 200 | - | - |

* C2, C3, C4, D3 - exhibit random distributions in the variogram construction so they were kriged with a short range (50 m) and a pure nugget effect, i.e. Co=SILL.

A6, C1 - each block was assigned the zone average from Table 4-10.

TABLE 4-12

SULPHUR DISTRIBUTION IN SUB-ZONE A5

Mean of 25 blocks = 0.886

Average std. error = 0.081

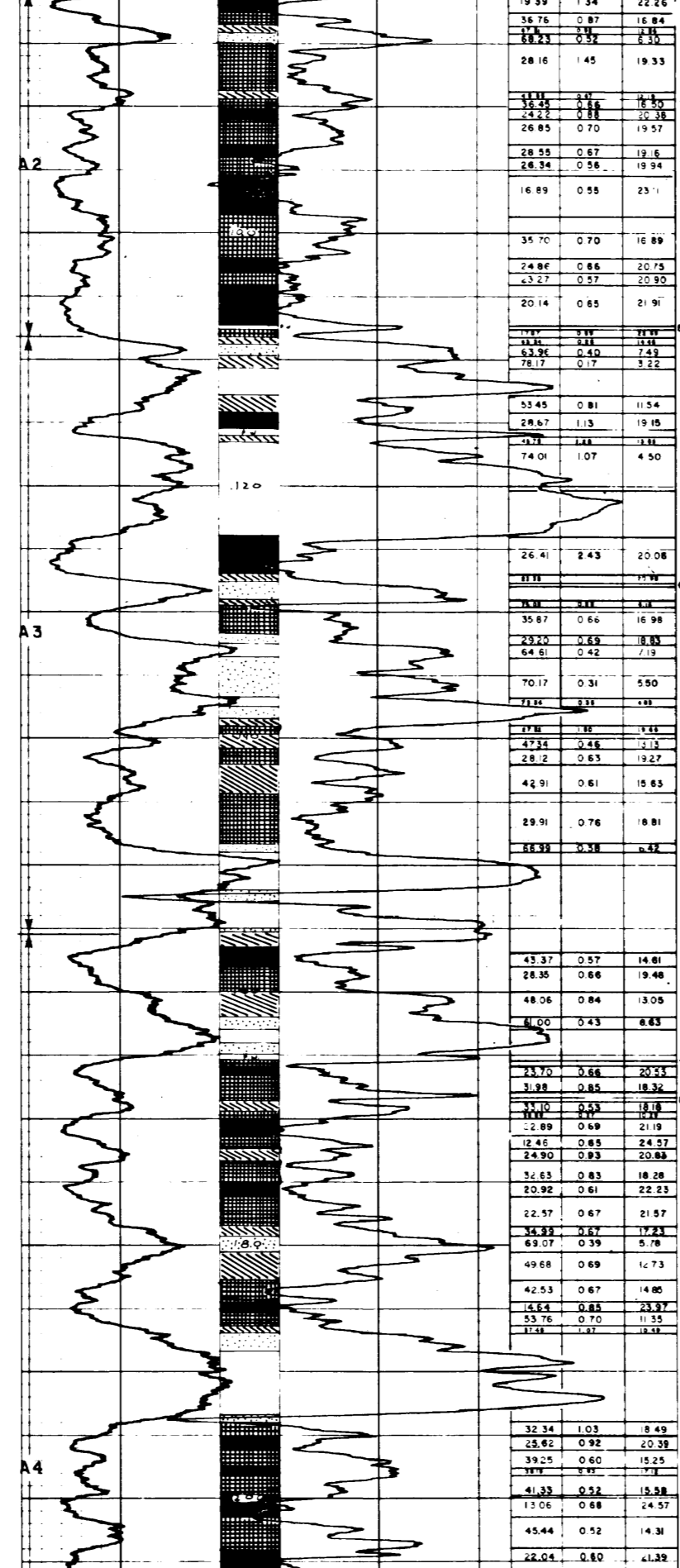
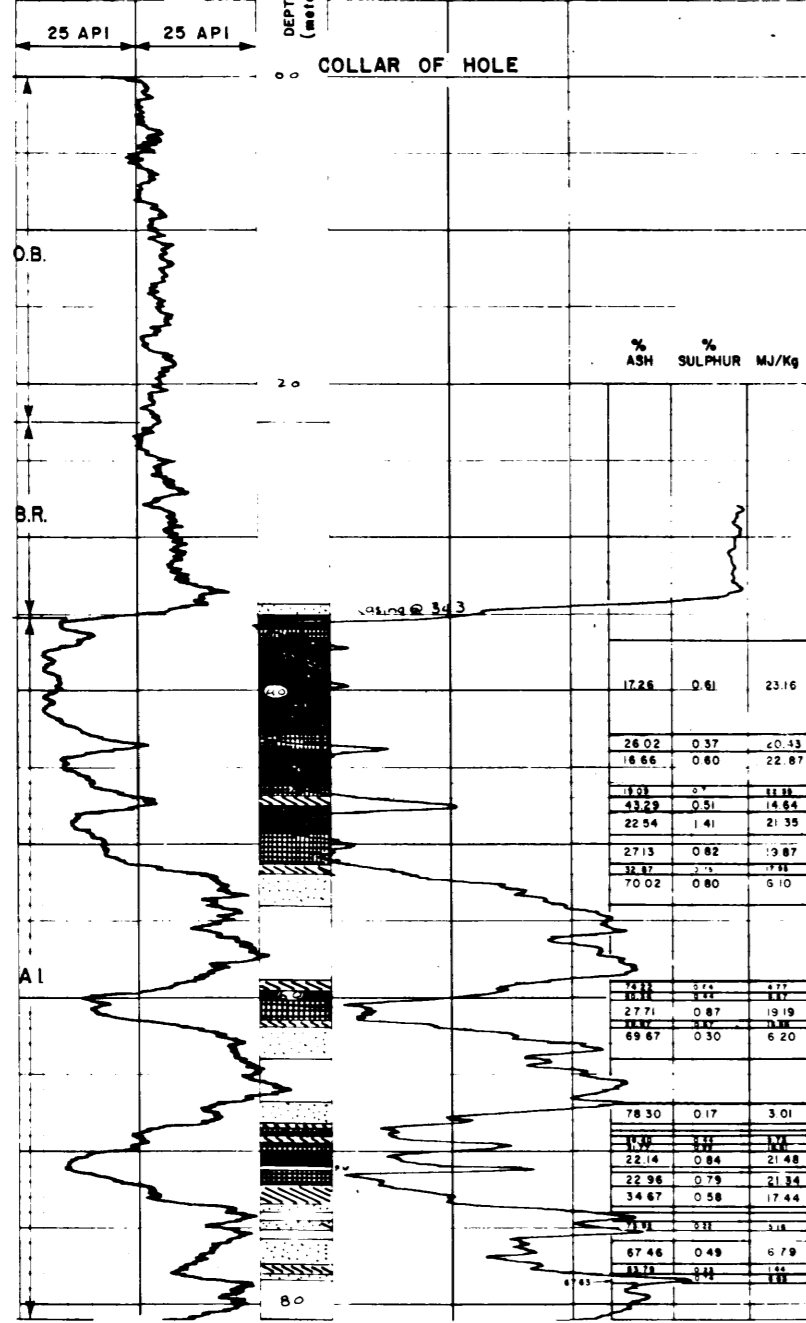
| | | | | | |
|----------------------|--------|-------|-------|-------|-------|
| Block Mean S% | 0.947 | 0.907 | 0.900 | 0.947 | 0.951 |
| Block Std. Error S% | 0.085 | 0.083 | 0.080 | 0.095 | 0.114 |
| No. of Intersections | 13 | 13 | 12 | 13 | 14 |
| | 0.0934 | 0.897 | 0.904 | 0.958 | 0.985 |
| | 0.078 | 0.079 | 0.072 | 0.085 | 0.102 |
| | 14 | 14 | 15 | 15 | 19 |
| | 0.870 | 0.835 | 0.857 | 0.943 | 1.027 |
| | 0.073 | 0.072 | 0.073 | 0.077 | 0.085 |
| | 16 | 17 | 17 | 19 | 19 |
| | 0.809 | 0.773 | 0.798 | 0.899 | 0.997 |
| | 0.072 | 0.069 | 0.071 | 0.076 | 0.083 |
| | 19 | 20 | 20 | 23 | 22 |
| | 0.768 | 0.741 | 0.759 | 0.831 | 0.923 |
| | 0.078 | 0.070 | 0.071 | 0.073 | 0.083 |
| | 20 | 20 | 23 | 25 | 23 |

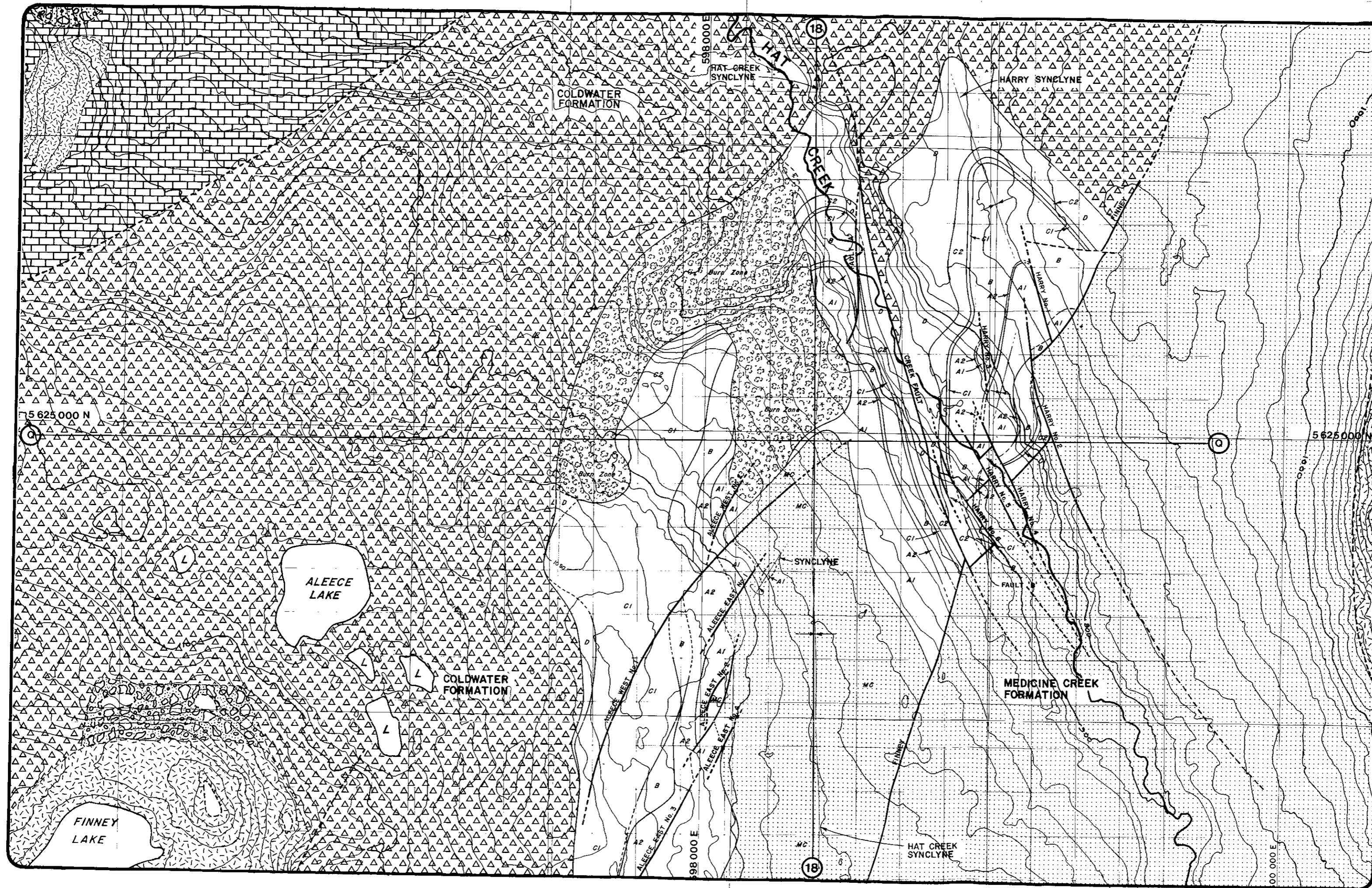
ROKE

OIL ENTERPRISES LTD. CALGARY, ALBERTA

| | | | | |
|------------------|------------------------------|----------|-------------------|-----------|
| FILE NO. | COMPANY | WELL | LOCATION | FIELD |
| 78-274 | B.C. Hydro & Power Authority | 78-274 | 7800 N 200 E 10 E | Hat Creek |
| PROVINCE | NAME | DATE | TIME | BY |
| British Columbia | | | | |
| LOG NO. | LOG TYPE | LOG DATE | LOG TIME | LOG BY |
| 130 | Gamma Ray | 1982 | 15:00 | K. J. ... |

| GENERAL | | GAMMA RAY | | | | NORMAL DISPLAY | | | | | |
|---------|-------|-----------|------|----------|-----------|-----------------|------|----------|-----------|---------|-------|
| RUN NO. | DEPTH | SPED | T.C. | SENG | ZERO | APR. LOG. UNITS | T.C. | SENG | SENG | CHG DIV | |
| FROM | TO | MIN | SEC | SETTINGS | DIV. OR A | PER LOG DIV | SEC | SETTINGS | DIV. OR A | | |
| 1 | 0.0 | 3.45 | 4 | 3 | 100 | 0 | 5 | 3 | 0.00 | 1.00 | 22.21 |
| 1 | 30 | 3.45 | 4 | | | | | | | | |



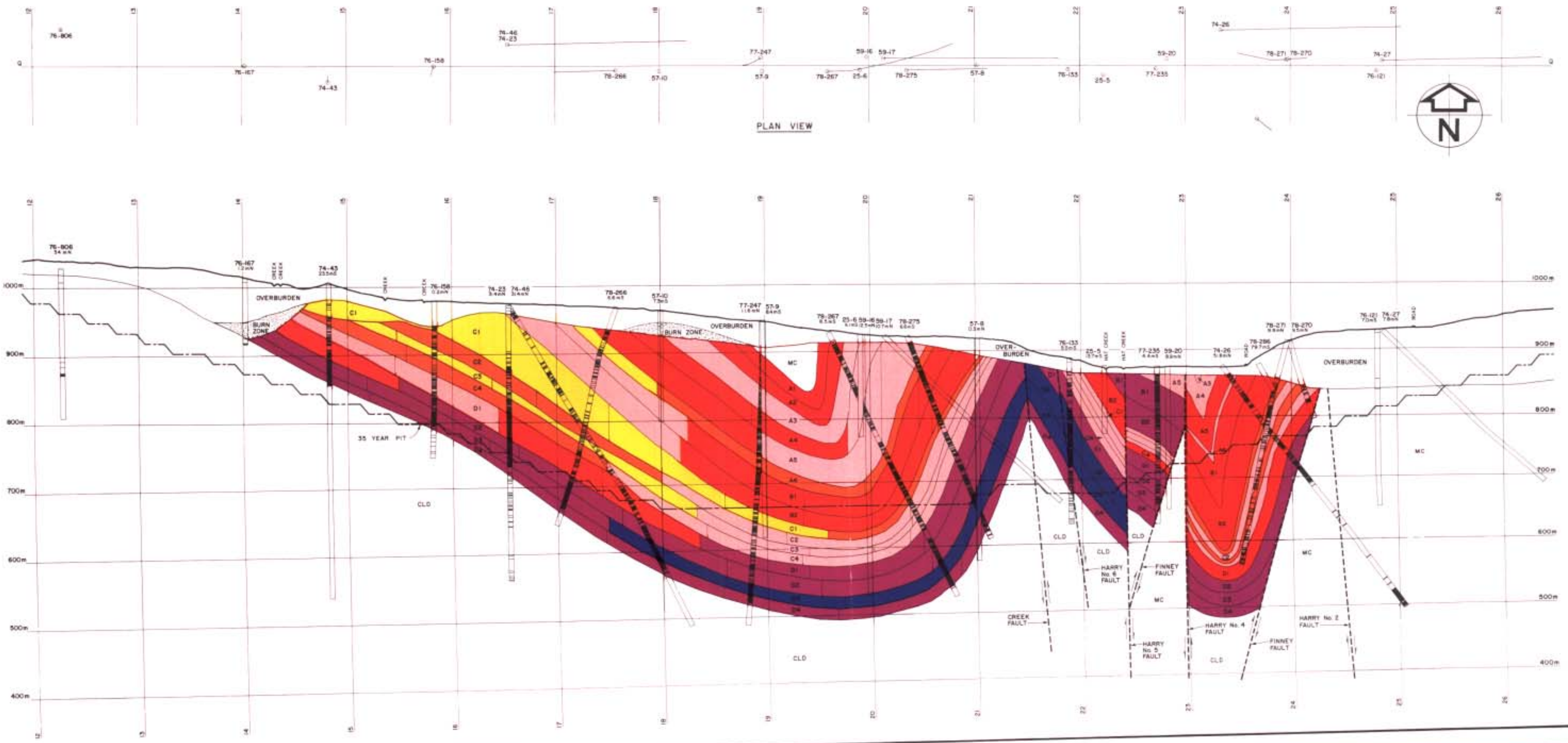


LEGEND

- | | |
|---|--|
| MIOCENE | CONIACIAN TO APTIAN |
| PLATEAU BASALTS Basalt, olivine basalt (13.2 m.y.), andesite, vesicular basalt | SPENCES BRIDGE GROUP Andesite, dacite, basalt, rhyolite tuff, breccias, agglomerate |
| MIOCENE OR MIDDLE EOCENE | MOUNT MARTLEY STOCK Granodiorite, tonalite |
| FINNEY LAKE FORMATION Lahar, sandstone, conglomerate | KAZANIAN TO VISEAN |
| EOCENE | CACHE CREEK GROUP MARBLE CANYON FORMATION Marble, limestone, argillite |
| MEDICINE CREEK FORMATION Claystone, siltstone | GREENSTONE Greenstone, chert, argillite, minor limestone and quartzite, chlorite schist, quartz-mica, schist |
| HAT CREEK FORMATION Coal, carbonaceous shale, claystone, siltstone, sandstone, conglomerate | OUTCROPS |
| SUBZONE & THICKNESS A1 110 - 225 m C1 0 - 170 m A2 0 - 90 m C2 15 - 55 m B 50 - 70 m D 60 - 100 m | 60 BEDDING OR LAYERING |
| COLDWATER FORMATION Claystone, siltstone, shale, sandstone, conglomerate | CONTACTS (Confirmed, inferred) |
| KAMLOOPS VOLCANICS Rhyolite, dacite, andesite, basalt and equivalent pyroclastics | FAULTS (Confirmed, inferred) |
| | LAKE |
| | BURNT COAL ZONE |

FIGURE 4-2
REGIONAL BEDROCK GEOLOGY
NO. 1 DEPOSIT

SOURCE: British Columbia Hydro and Power Authority



LEGEND

- SPECIFIC ENERGY RANGES
MJ/kg (DRY BASIS)**
- < 9.3
 - 9.3 - 13.0
 - 13.0 - 16.5
 - 16.5 - 20.0
 - 20.0 - 24.0
 - > 24.0
- MC MEDICINE CREEK FORMATION
 - CLD COLDWATER FORMATION
 - BURN ZONE
 - A6 A6 SUB-ZONE
 - C1 C1 SUB-ZONE
 - FAULT
 - CONTACT
 - RELATIVE MOVEMENT

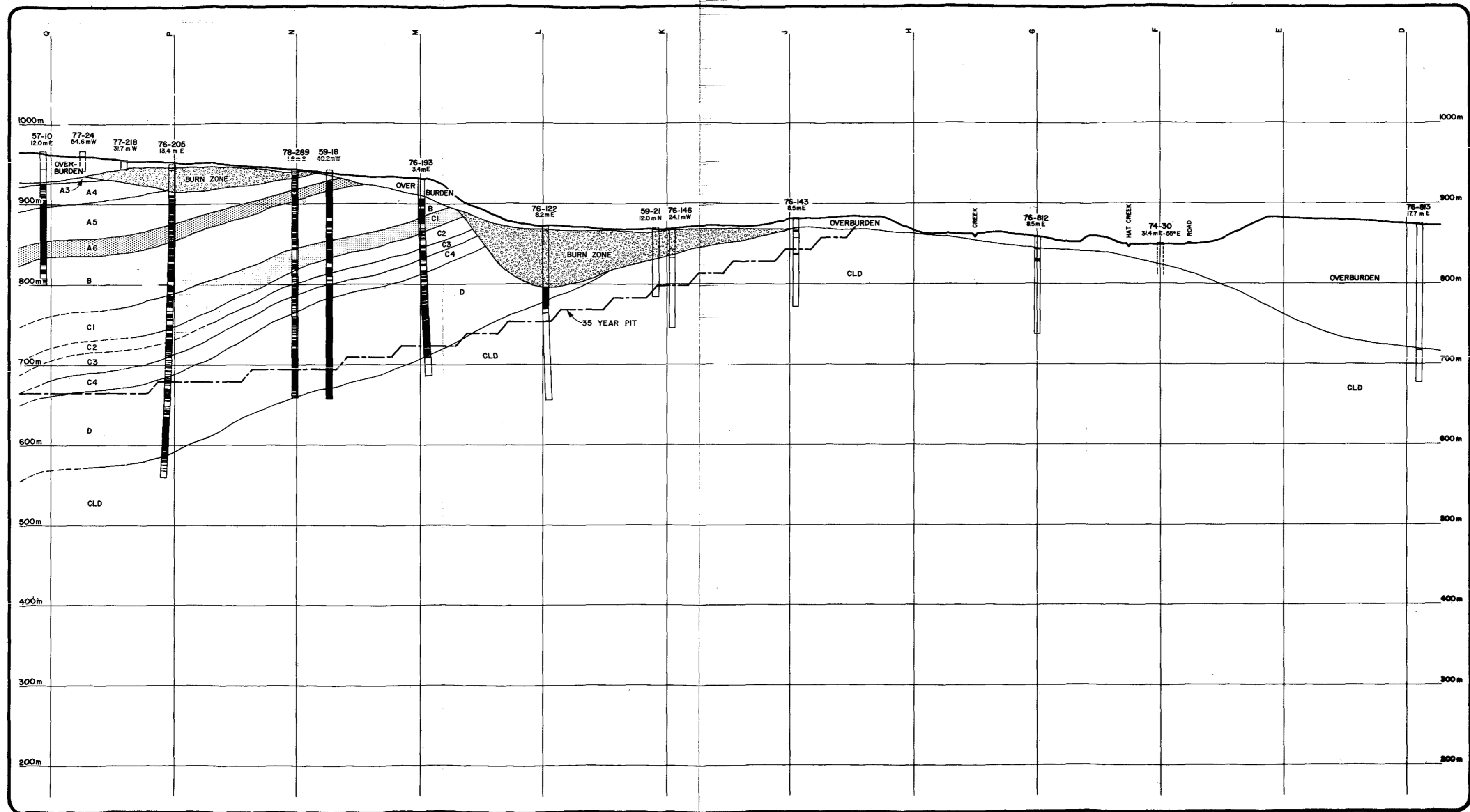
SUBZONE & THICKNESS

| | |
|-------------|-------------|
| A1 15 - 35m | C1 0 - 170m |
| A2 20 - 55m | C2 5 - 20m |
| A3 25 - 45m | C3 5 - 15m |
| A4 20 - 45m | C4 5 - 20m |
| A5 30 - 45m | D1 15 - 25m |
| A6 0 - 90m | D2 15 - 30m |
| B1 25 - 35m | D3 15 - 25m |
| B2 25 - 35m | D4 15 - 20m |



HAT CREEK PROJECT
FIGURE 4-3
GEOLOGICAL CROSS SECTION
SECTION Q
 SECTION DRAWN LOOKING NORTH

SOURCE: British Columbia Hydro and Power Authority

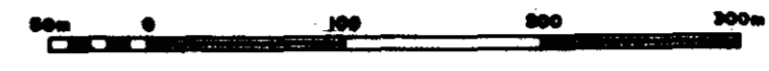


LEGEND

- MC MEDICINE CREEK FORMATION
- CLD COLDWATER FORMATION
- BURN ZONE BURN ZONE
- A6 A6 SUB-ZONE
- C1 C1 SUB-ZONE
- FAULT
- - - CONTACT
- ⇌ RELATIVE MOVEMENT

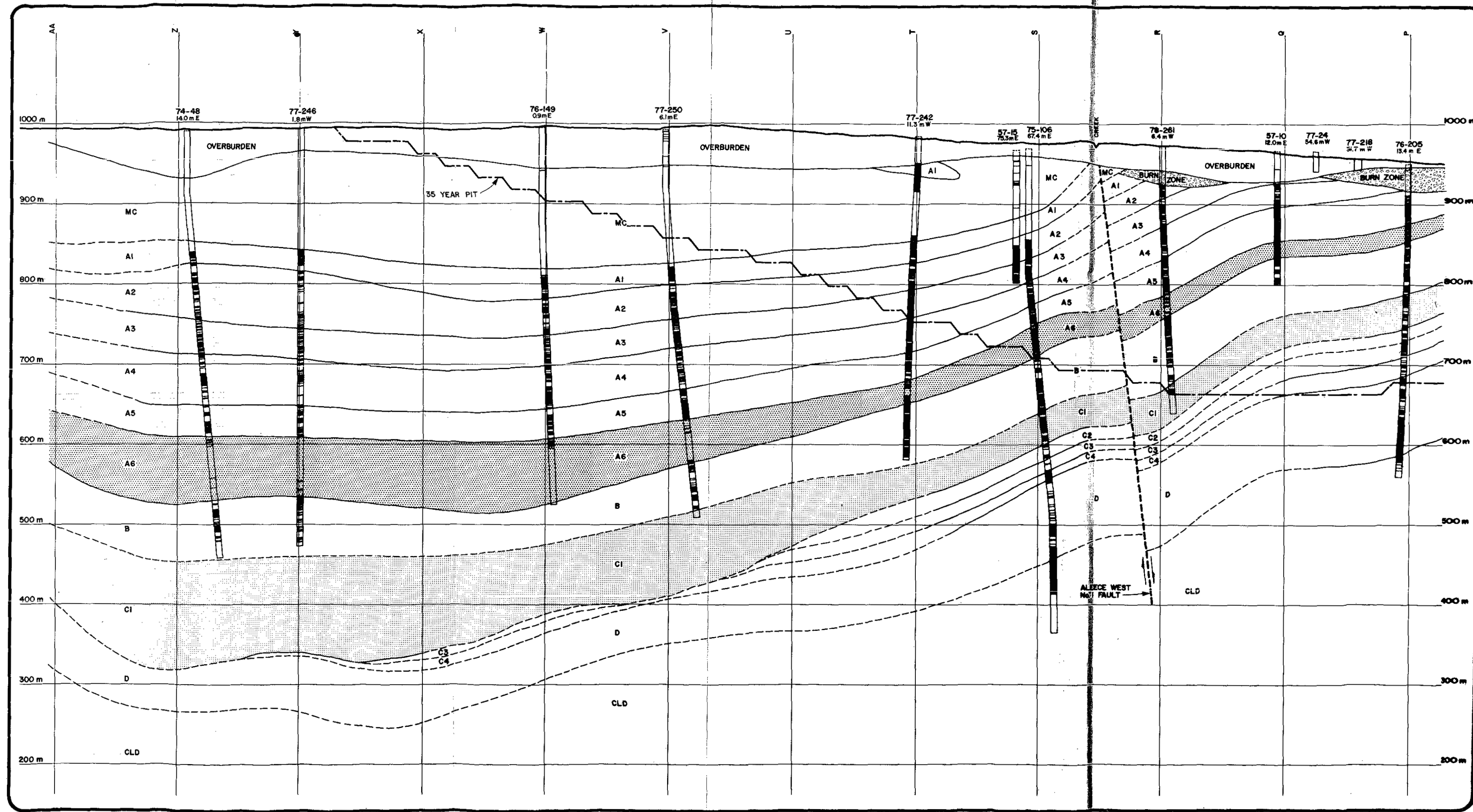
SUBZONE & THICKNESS

| | |
|-----------|-----------|
| A1 15-35m | C1 0-170m |
| A2 20-55m | C2 5-20m |
| A3 25-45m | C3 5-15m |
| A4 20-45m | C4 5-20m |
| A5 30-45m | D1 15-25m |
| A6 0-90m | D2 15-30m |
| B1 25-35m | D3 15-25m |
| B2 25-35m | D4 15-20m |



HAT CREEK PROJECT
FIGURE 4-4A
GEOLOGICAL CROSS SECTION
18 NORTH
SECTION DRAWN LOOKING WEST

SOURCE: British Columbia Hydro and Power Authority



LEGEND

- MC MEDICINE CREEK FORMATION
- CLD COLDWATER FORMATION
- A6 A6 SUB-ZONE
- C1 C1 SUB-ZONE
- FAULT
- CONTACT
- RELATIVE MOVEMENT

SUBZONE & THICKNESS

| | |
|-----------|-----------|
| A1 15-35m | C1 0-170m |
| A2 20-55m | C2 5-20m |
| A3 25-45m | C3 5-15m |
| A4 20-45m | C4 5-20m |
| A5 30-45m | D1 15-25m |
| A6 0-90m | D2 15-30m |
| B1 25-35m | D3 15-25m |
| B2 25-35m | D4 15-20m |



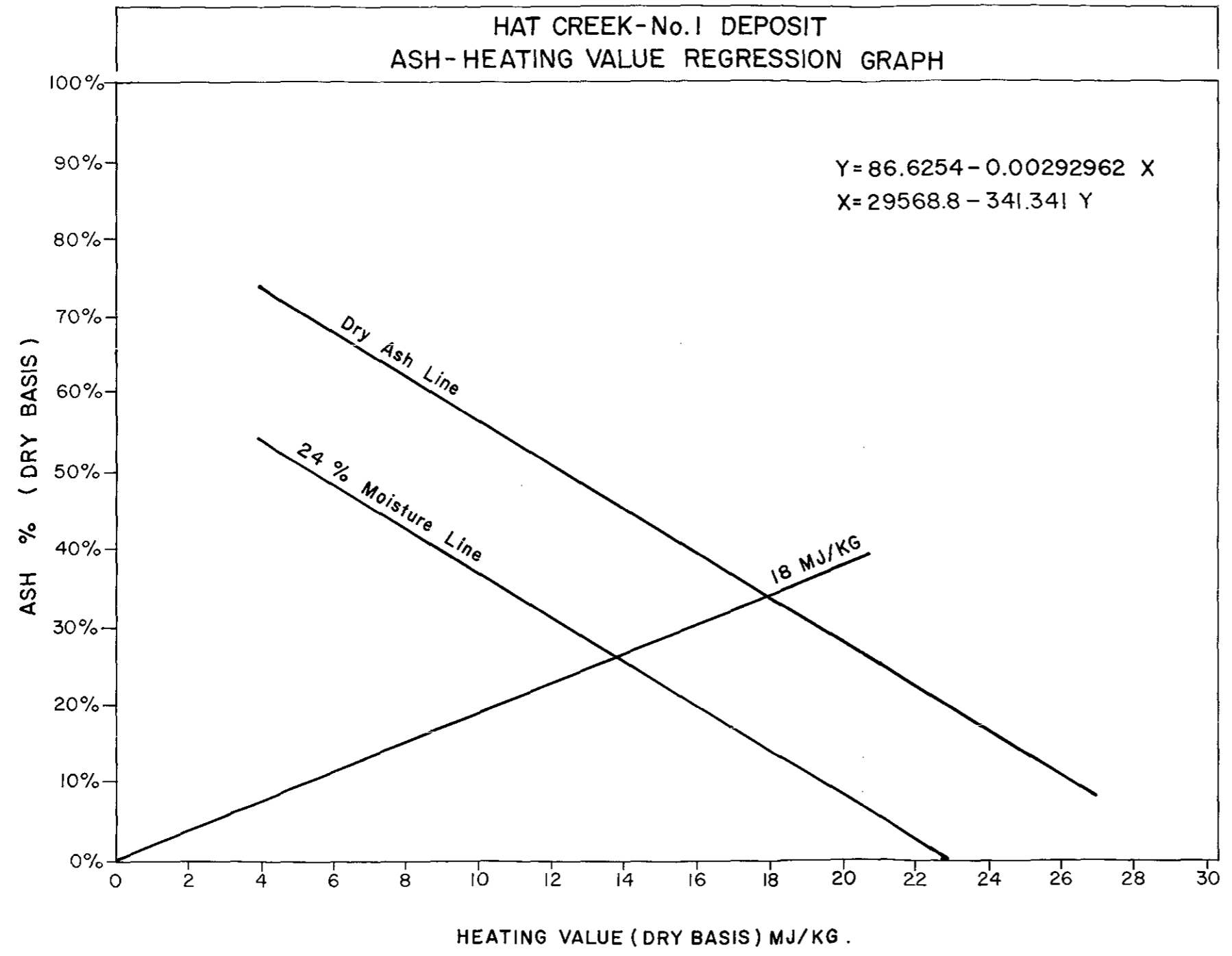
HAT CREEK PROJECT

FIGURE 4-4B

**GEOLOGICAL CROSS SECTION
18 SOUTH**

SECTION DRAWN LOOKING WEST

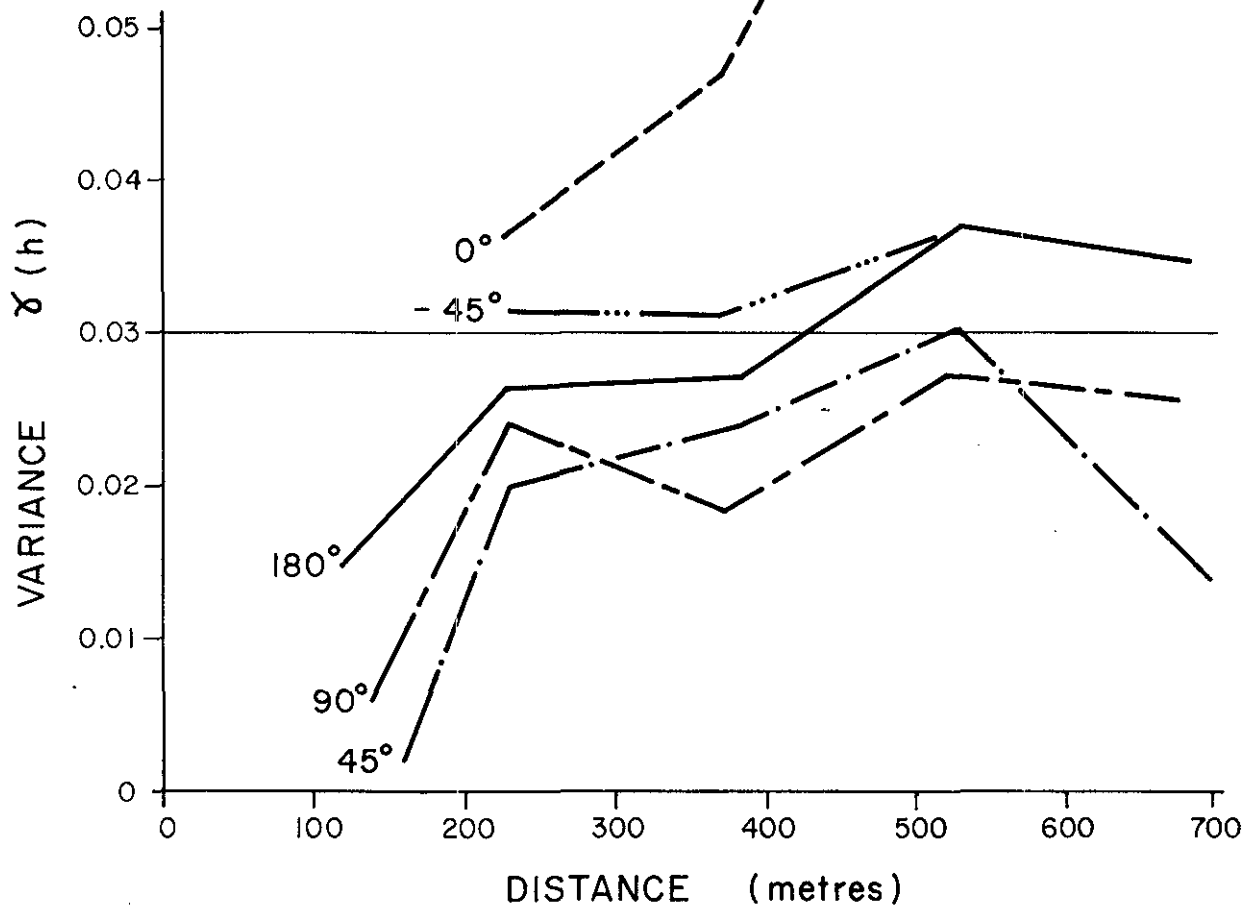
SOURCE: British Columbia Hydro and Power Authority



NOV. 1979

HAT CREEK PROJECT
FIGURE 4-5
Regression Curve
Ash-Heating Value (Ash < 60%)

SOURCE: British Columbia Hydro and Power Authority



HAT CREEK PROJECT

FIGURE 4-6

Sample Semi-Variogram, Sulphur — Sub Zone A2

SOURCE: British Columbia Hydro and Power Authority

| 5 | <u>MINE PLANNING</u> | <u>Page</u> |
|----------|---|-------------|
| 5.1 | Introduction | 1 |
| 5.2 | Design Criteria | 3 |
| 5.2.1 | Powerplant Requirements | 3 |
| 5.2.1.1 | Powerplant Needs at Target Quality | 3 |
| 5.2.1.2 | Allowable Coal Quality Variations | 4 |
| 5.2.2 | Material Delivery Points and Mine Facilities Location | 4 |
| 5.2.3 | Geotechnical Constraints | 5 |
| 5.2.3.1 | Introduction | 5 |
| 5.2.3.2 | The Nature of the Materials in the No. 1 Deposit | 6 |
| 5.2.3.3 | Geotechnical Conclusions | 6 |
| 5.2.3.4 | The 35-Year Pit Design | 8 |
| 5.2.3.5 | Handling Overburden Surficial Deposits | 8 |
| 5.2.3.6 | Bench Strengths | 9 |
| 5.2.3.7 | Other Geotechnics | 10 |
| 5.2.3.8 | Field-Test Knowledge and Experience (Bulk Sample Program) | 11 |
| 5.2.3.9 | Mining Methods Assumptions | 11 |
| 5.2.3.10 | Ultimate Slopes | 12 |
| 5.2.4 | Hydrology | 13 |
| 5.2.4.1 | The Hydrology Program | 13 |
| 5.2.4.2 | Hydrological Relationship to Geotechnical Constraints | 13 |
| 5.2.4.3 | Work Programs and Methods Used to Determine the Hydrology | 14 |
| 5.2.4.4 | Conclusions | 15 |
| 5.2.4.5 | The Hydrogeological Picture of the Hat Creek Valley | 15 |
| 5.2.4.6 | Controls and Preventive Measures | 16 |
| 5.2.4.7 | Evaluation of Piezometer Hydrographs | 17 |
| 5.2.5 | Material Characteristics | 18 |
| 5.2.5.1 | General Description | 18 |
| 5.2.5.2 | Specific Gravity | 20 |
| 5.2.5.3 | Swell Factors | 21 |
| 5.2.5.4 | Material Cutting Resistance | 22 |
| 5.2.5.5 | Bearing Capacity of Materials | 22 |
| 5.2.6 | Dilution and Mining Loss | 23 |
| 5.2.6.1 | Dilution | 23 |
| 5.2.6.2 | Mining Loss | 23 |

| | <u>Page</u> |
|---|-------------|
| 5.2.7 Selective Mining | 24 |
| 5.2.7.1 Definition | 24 |
| 5.2.7.2 Selective Mining Methods | 25 |
| 5.2.7.3 Selective Mining Evaluation | 26 |
| 5.3 Mining Methods | 28 |
| 5.3.1 Review of Alternatives | 28 |
| 5.3.2 The Shovel/Truck/Conveyor System | 29 |
| 5.4 Pit Design and Production Scheduling | 34 |
| 5.4.1 Planning Data | 34 |
| 5.4.2 The Dipper System | 34 |
| 5.4.3 Pit Design | 36 |
| 5.4.4 Production Scheduling | 37 |
| 5.5 Waste Dumps and Embankments | 39 |
| 5.5.1 General | 39 |
| 5.5.2 Geotechnical Constraints and Parameters | 39 |
| 5.5.2.1 Material Parameters | 39 |
| 5.5.2.2 Parameters of Waste Dumps and Embankments | 40 |
| 5.5.3 Construction and Development | 41 |
| 5.5.3.1 Construction of Access Roads and Initial Conveyor Pads | 42 |
| 5.5.3.2 Dumping General Waste | 42 |
| 5.5.3.3 Construction of Embankments | 43 |
| 5.5.4 The Houth Meadows Waste Dump | 43 |
| 5.5.5 The Medicine Creek Waste Dump | 45 |
| 5.5.6 Conclusions and Recommendations Relating to Waste Disposal Embankment Studies | 46 |
| 5.5.6.1 Conclusions | 46 |
| 5.5.6.2 Recommendations | 47 |

| <u>No.</u> | <u>LIST OF TABLES</u> | <u>Page</u> |
|------------|--|-------------|
| 5-1 | Description of Surficial Materials | 48 |
| 5-2 | Description of Rock Materials | 49 |
| 5-3 | Hydraulic Conductivity Results | 50 |
| 5-4 | Incremental Design Pit Quantities | 51 |
| 5-5 | Adjusted Production Schedule | 52 |
| 5-6 | Schedule Annual Production | 53 |
| 5-7 | Houth Meadows Waste Dump - Capacity by Lift | 54 |
| 5-8 | Medicine Creek Waste Dump - Capacity by Lift | 55 |

LIST OF FIGURES

| | | |
|------|---|----|
| 5-1 | Interim Pit Development: Cross-section Q | 56 |
| 5-2 | Uniaxial Compressive Strengths | 57 |
| 5-3 | Pit Slopes | 58 |
| 5-4 | Generalized Piezometric Surface Contours of Bedrock Materials | 59 |
| 5-5 | Hydraulic Conductivity Values Determined In Situ | 60 |
| 5-6 | Hydrology, Section Through Hat Creek Valley | 61 |
| 5-7 | Mine Seepage and Dewatering Flow Chart | 62 |
| 5-8 | Depressurization by Excavation | 63 |
| 5-9 | Typical VBM Cross-section | 64 |
| 5-10 | Bench Plan - Elevation 775 | 65 |

LIST OF FIGURES (Continued)

Page

| | | |
|------|-------------------------|----|
| 5-11 | Cone Geometry | 66 |
| 5-12 | Pit Development Year -1 | 67 |
| 5-13 | Pit Development Year 5 | 68 |
| 5-14 | Pit Development Year 8 | 69 |
| 5-15 | Pit Development Year 15 | 70 |
| 5-16 | Pit Development Year 25 | 71 |
| 5-17 | Pit Development Year 35 | 72 |
| 5-18 | Dump Development | 73 |
| 5-19 | Houth Meadows Dump | 74 |
| 5-20 | Medicine Creek Dump | 75 |
| 5-21 | Waste Dump Slopes | 76 |

SECTION 5

MINE PLANNING

5.1 INTRODUCTION

The objective of this study is to develop a mining plan that is both technically practicable and economically sound. Its purpose is to provide a reliable supply of coal of consistent quality to meet the forecast requirements of the powerplant over the estimated 35-year project life.

Conceptual design studies completed in 1976 by Powell Duffryn - National Coal Board (PD-NCB) evaluated the potential mining methods and economics of mining both the No. 1 and the No. 2 deposits. From these studies, the recommendation was accepted that the No. 1 Deposit was the more economic for development and that open-pit mining was the most appropriate method. This section describes the basis and the methods of planning used, and presents the pit design and production schedules developed.

The plan developed must incorporate adequate safeguards to ensure the safety of the work force. Environmental objectives must be met and adverse impacts reduced as much as possible. Effective utilization of the resource should be maximized.

Because the time frame for this plan extends beyond 40 years it is important that options for future development are not foreclosed. Thus a major constraint in planning the mine is to ensure that planned activities do not jeopardize the possibility of ultimately mining the total reserve in the No. 1 Deposit or impede development of the No. 2 Deposit. To meet this constraint, the pit has been developed in a logical, sequential manner to produce 35 years' coal supply. The pit is developed with working slopes a few degrees flatter than the designed final pit slope. As the pit limits are reached, the slopes are steepened to conform to the design. Should it become necessary to extend the life of the pit, the degree of difficulty entailed would be directly related to the lead time associated with the change of plan. A decision made to extend mining before final pit slopes are reached would permit a smooth continuation of the operation. A last minute decision would result in the need for flattening pit slopes all the way to the surface before significant tonnages of coal could be produced.

Should the total resource of the No. 1 Deposit ultimately be mined, the pit would be over 200 m deeper than the presently planned pit. The technical and economic feasibility of mining to this greater depth has not been established. Further studies, both mining and geotechnical, would be required for this purpose.

In locating permanent facilities and waste dumps, care was taken to ensure that they were placed beyond the projected ultimate pit limits. The exceptions to this are the locations of the Hat Creek Diversion Canal, the headworks dam, and the pit rim dam. In these cases, it was shown to be more economic to relocate the facilities when necessary.

A prerequisite to any significant development of the coal deposits is the diversion of Hat Creek. The Hydro Electric Design Division of B.C. Hydro has prepared a Preliminary Engineering Design Report for the diversion of both Hat Creek and Finney Creek. The results of this work have been incorporated in this report.

The planned diversion of Hat Creek consists of a headworks dam to control the flow and channel it into a diversion canal, which carries the water around the East side of the pit before returning it through a buried conduit to the creek downstream of the mine facilities. The diversion system is designed to handle the 1,000-year return flood. An emergency spillway is incorporated into the headworks structure to prevent the overtopping of the dam with the overflow water channelled to the mine.

5.2 DESIGN CRITERIA

5.2.1 Powerplant Requirements

Based on the planned powerplant operating regime, annual coal consumption was determined from pre-production to the end of Year 35. These fuel requirements were established for the following functions:

- (1) Commissioning of boiler units in the pre-production year and the first three years of operation;
- (2) Establishing a two-week dead stockpile at the powerplant and a one-week live blending pile at the mine;
- (3) Annual commercial power generation based on forecast capacity factors.

5.2.1.1 Powerplant Needs at Target Quality

The powerplant needs based on target quality of 18 MJ/kg dry basis and 23.5% moisture are as follows:

| <u>Year</u> | <u>Boiler Units</u> | <u>Net Capacity (MW)</u> | <u>Average Capacity Factor (%)</u> | <u>Million Tonnes at 18 MJ/kg Dry Basis and 23.5% Moisture</u> |
|----------------|---------------------|--------------------------|------------------------------------|--|
| Pre-Production | | | | 1.11 |
| 1 | 1 | 500 | 69 | 3.15 |
| 2 | 2 | 1,000 | 60 | 4.79 |
| 3 | 3 | 1,500 | 60 | 7.35 |
| 4 | 4 | 2,000 | 61 | 9.45 |
| 5 | 4 | 2,000 | 65 | 10.60 |
| 6-15 | 4 | 2,000 | 70 | 10.86/year |
| 16-25 | 4 | 2,000 | 65 | 10.09/year |
| 26-35 | 4 | 2,000 | 55 | 8.53/year |

A further potential coal demand that the mine must be capable of satisfying could occur if the powerplant is required to operate continuously for a period of up to six months at maximum continuous rating on all four units.

5.2.1.2 Allowable Coal Quality Variations

A live stockpile of 300,000 t of coal (one week's coal supply at maximum rating on all four units) would be used to blend the run-of-mine coal and minimize the quality variations.

The quality of coal delivered to the powerplant may vary between 17 MJ/kg and 19 MJ/kg, with a sulphur content between 0.46% and 0.56% on a dry coal basis.

5.2.2 Material Delivery Points and Mine Facilities Location

The delivery points for coal and waste, and two locations for the construction of the mine facilities complex, are as follows:

Coal

The coal delivery point, determined in consultation with the powerplant engineering staff, is the receiving conveyor at the powerplant. The responsibility of the mine for coal-handling terminates at this location.

Low-grade Coal

Low-grade coal will be delivered to a dry beneficiation plant. Provision must be made to combine beneficiated coal with the run-of-mine coal and to remove rejects to the waste dumps.

Waste

Mine waste must be contained in waste dumps close to the mine. Weak waste materials must be retained by engineered embankments. Dumps must not overlie any coal or be located where they will restrict

any possible pit expansion. Houth Meadows and Medicine Creek have been identified as suitable areas for waste dumps. Small areas around the No. 1 Deposit and close to the proposed dumps will be used as temporary topsoil storage areas.

Mine Facilities Complex

Potential locations for constructing the mine facilities complex are:

- (1) The North-Eastern end of the Upper Hat Creek Valley South of Indian Reserve IR-1 and bounded by Harry Creek and Hat Creek;
- (2) The area located North-East of the confluence of Hat Creek and Medicine Creek, and between the No. 1 and the No. 2 Deposit.

The mine facilities complex and any other permanent structures should be 300 m minimum distance from the rim of the ultimate pit and not overlie any coal.

5.2.3 Geotechnical Constraints

5.2.3.1 Introduction

A geotechnical assessment program was initiated and assigned to Golder Associates in 1976. Extensive field investigations took place along with the exploration drilling programs over three years, with special drilling programs directed to geotechnical objectives. The major purpose of the work has been to establish safe working slopes for the open-pit mine in the No. 1 Deposit.

The stability of these slopes is controlled by the strength of the materials and the groundwater conditions in the area.

The reports by Golder Associates culminate in a final report: "Geotechnical Study 1977-78" dated December, 1978. There are six volumes presenting the detailed findings of all the work, with 16 appendices supporting the main text.

5.2.3.2 The Nature of the Materials in the No. 1 Deposit

The unconsolidated overburden is mostly strong granular glacio-fluvial sands, gravels, and till.

The slide material is very weak, consisting of loose, mixed debris, mostly soft and bentonitic.

The bedrock, soft clays, and siltstones exhibit varying low strengths and are weak when compared with hard rock formations.

The coal has greater strength than the above, but is still weak.

Overall, the materials represent saturated weak rocks that were originally deposited in a lacustrine environment and are softened when wet.

5.2.3.3 Geotechnical Conclusions

Pit Slope Stability

The following design slope angles recommended by Golder Associates for the 1978 Mining Feasibility Report by CMJV have been accepted for this Mining Report. Figure 5-3 presents Golder Associates' schematic diagram for these angles around the pit.

| | |
|--|-----|
| Surficial deposits (other than slide debris) | 25° |
| Slide debris | 16° |
| Coal | 25° |
| Coldwater rocks (other than coal) | 20° |

The results of laboratory strength tests carried out on the Coldwater rocks show a wide spread in values, but do not indicate significant variations between different sectors of the pit. Therefore, there is no justification at this stage for varying the slope angles within the different Coldwater rock materials. As more data is accumulated

in the future during the detailed design phase and early excavation, further refinement of slope angles can be anticipated.

In arriving at these steeper recommended angles, the following assumptions have been made:

- (1) That pit slope depressurization by negative pore pressure generation would be moderately successful;
- (2) That slopes would be excavated to flat angles during the initial process of mining, both to minimize shearing stresses that could lead to progressive slope failures and to promote slope depressurization;
- (3) That interim bench failures would be acceptable, that increased road maintenance would be necessary, and that wider benches would be needed locally;
- (4) That slope height is generally not dependent on slope angle, because the design is based on the lower limiting strength of the material; and
- (5) That slopes are designed to be stable only for the duration of mining.

During the current study it became apparent that depressurization would be more difficult to achieve than anticipated and that, except in restricted areas, conventional means (pumping wells, adits, horizontal drains) would not be appropriate. However, the current design is markedly different from the PD-NCB pit, on which all the original work was done (see Golder Associates' Report No. 6). The pit involves flatter interim pit slopes than final slopes and a progressively expanding pit which generally does not excavate slopes to final depth until the last 10 years. The geotechnical consequences of this design are favourable, since the materials in the slopes would only be stressed at low levels during the earlier years of mining (see Figure 5-1). Much experience could be gained within the deposit while slopes of modest height were cut at flat angles. Moreover, the in-situ ground-water studies and the laboratory testing program have indicated that depressurization by the development of negative pore pressures on excavation should be a significant factor in maintaining slope stability. (Figure 5-8)

The major conclusions on slope stability for the Mining Report are, therefore, that the final slopes can be excavated at the slope angles stated above, but with the following reservations:

- (1) That it would be possible to achieve slope stabilization by pumping or gravity drainage only in very limited areas of the pit;
- (2) That whilst slope stabilization by the development of negative pore pressures is likely to be effective in many areas of the pit, it would also be marginal in some places; these areas are difficult to predict in advance;
- (3) The approach to mine planning currently being used permits valuable experience to be gained with the slopes whilst negative pore pressures are still operative in the earlier years.

5.2.3.4 The 35-Year Pit Design

Flatter interim pit slope angles in the coal benches during the opening up or development of the pit have been incorporated (see Figure 5-1).

The overall slope during any interim pit phase will always be less than the recommended final slope angles.

To minimize bench instability along bedding planes when the dip is out of the mining face, the benches should preferably be aligned in such a way that they are not parallel with the strike of the beds, but rather make an angle of at least 20° with that direction.

In the event of the dip of the bedding being less than 30° and out of the face, with the strike of the bedding parallel to or within 20° of the face alignment, the slope of the mining benches should be reduced to the slope of the bedding. This precaution is not necessary where the dip of the bedding is less than 20° .

5.2.3.5 Handling Overburden Surficial Deposits

The sand, gravel, and glacial silts on the Eastern perimeter are 92 m to 122 m thick and will be required for construction and fill purposes early on. The materials are dense in situ and will be stable at much steeper slopes than the bedrock clays. However, there is

a water table contact with the top of the bedrock that may present drainage problems.

The slide masses on the Western and South-Western perimeters present a stability problem. Movement of these slide masses could be re-activated along pre-existing slide planes due to excavation disturbances of their equilibrium, or by water flow or pressure. Experience has shown that movement of these slides would be of a slow, creeping nature.

A drainage program will be initiated and maintained to reduce this potential threat. Also, the slide front around the perimeter of the pit will need clearing back and a "creep-monitoring" system set up.

The active slide on the North-West perimeter will be stabilized by surficial drainage, diverting Hat Creek, and putting in a fill ramp at the toe of the slide across the valley as a bridge for the conveyor and access road to Houth Meadows Waste Dump.

The slide materials are mostly bentonitic clays and volcanic debris or breccia. About 30 million m³ of this material will have to be excavated in the 35-year pit, and it is known to be very sticky and difficult to handle when wet in Springtime. It may be impractical to maintain benches for more than two years in this unconsolidated overburden on the Western side. Rather, the ground could be evenly sloped to 16° from bedrock to surface perimeters.

5.2.3.6 Bench Strengths

For economic efficiency, a standard bench height of 15 m has been considered to be practical and safe. Local conditions may dictate using lesser bench heights.

Instability of some benches would be time-dependent, where failures could depend on the dissipation of pore pressures. Much of this activity is expected to develop within weeks or months of the digging (page 78, Golder).

The clay-rich rocks, being dispersive, are highly susceptible to erosion by water, especially when brecciated.

Much clean-up work should be expected on a regular basis, because of the highly dispersive nature of the lower claystone on the Western side of the pit. Mine operations will have to carefully plan the approach and access for a return to areas where the benches have been left standing for a number of years.

5.2.3.7 Other Geotechnics

1. Faults

Where possible, faults are mined in the direction of the dip, so that the zone is traversed as quickly as possible and the fault is first met in the upper part of the face. Removal of weak, faulted ground and unloading of the lower part of the face containing the faults is therefore possible.

The weakest members of the coal sequences are normally the argillaceous interbeds along which tectonic shearing has often developed (page 73, Golder). The stability of any slope formed in the coal would therefore be dependent on the orientation of the bedding planes in relation to the bench orientation. Local joint sets and unique structures such as faults would cause local stability problems.

This situation is well exemplified in Trench A, where the Northern and Southern faces were excavated normally to the strike and are stable. The Western face was excavated parallel to the strike and is unstable.

2. Waste Dumps

Because of the large proportion of the weak bentonitic clay, conventional mine waste dumps are not feasible. It is necessary to store the material behind engineered embankments. No major geotechnical problems are envisaged for waste dump or embankment stability, either in Houth Meadows or Medicine Creek, provided material quality selection and the recommended designs are adhered to.

Embankments would be constructed of clean granular fill from the stripping of the glacio-fluvial sands and gravels; the materials could be placed by spreader.

The conglomeratic unit of the Coldwater Formation below the coal would provide a sufficiently strong buttress between the Houth Meadows Waste Dump and the pit to inhibit instability during the pit operation.

5.2.3.8 Field-Test Knowledge and Experience (Bulk Sample Program)

The bulk sample excavations were undertaken in 1977 in disturbed, weathered materials above the water table. Much information has been obtained from this work program defining the strength and nature of the materials in both coal and waste zones. Equipment performance of motor scrapers, hydraulic shovel excavators, rear dump trucks, and bulldozer ripping, coal-crushing, waste dump stability, road-making, revegetation of dumps, drainage conditions, and climatic effects of freezing-thawing on bench faces causing detrition - were all studied and yielded basic information from which conclusions have been drawn for mine planning.

The strength and nature of the deep-seated coal and clay beds has been geotechnically evaluated by testing drill core samples from exploration drilling programs covering the entire No. 1 Deposit and its adjacent perimeter area. The results of uniaxial compressive strength-testing of the rocks are presented graphically in Figure 5-2 by Golder Associates.

5.2.3.9 Mining Methods Assumptions

Selective mining by careful removal of the clay partings within the coal beds has been planned. Drilling and blasting the benches is neither required nor desirable; hydraulic excavators can do the digging efficiently and provide the selectivity of materials for loading in trucks. (Golder's Tables 5-1 and 5-2 indicate the test results of the various materials and "diggability" under "Geotechnical Comments".)

The changes that will necessarily be introduced into the geometry of pit slopes as mining proceeds can only be determined as actual experience in excavation of the various materials is obtained.

Adoption of a flexible mine plan and selection of equipment initially must allow for changes in mining methods and pit design later on.

5.2.3.10 Ultimate Slopes

The eventual dissipation or equilibration of negative pore pressures may induce slides in the final pit slopes. The process would probably be one of progressive failure, with the back scarp of the slide retreating over many, possibly hundreds of, years until a stable situation is achieved. One way to prevent this would be to back-fill the excavation of the No. 1 Deposit with fill from waste excavated from the No. 2 Deposit if it is eventually mined by open-pit methods.

It is anticipated that after a period of mining, the pit will have grown to a size that will require realignment or replacement by other means, such as a tunnel or conduit of some 1,400 m of the Hat Creek Diversion Canal. Subsequent realignment of the canal to suit the ultimate pit slope is considered to be the most economical arrangement, but mining of the total resource may preclude this due to the surface ground slope.

The alternative scheme for the long-term diversion of Hat Creek is to put it in a tunnel around the Eastern side of the pit. The timing of the construction of this tunnel will depend on what happens with mining and slope stability near the canal. The surface ground between the pit excavation and the canal will be constantly monitored for both effectiveness of depressurization during mining and also for signs of movement or "creep". Such movement could lead to cracking or rupture of the canal, causing seepage into the Eastern side pit walls and consequent instability. Action will be taken to relocate the canal when necessary.

5.2.4.4 Conclusions

Hydraulic conductivities of all the zones in the pit area are very low except in the surficial materials (gravel and sand overburden). Permeability of the bedrock zones and the coal was so low that no pumping could be done; hand-bailing methods were used.

In general, depressurization by dewatering is not likely to be effective in these bedrock zones; pumping and drainage cannot be relied on to reduce the pore pressures in working slopes, because the ground is too impermeable.

Piezometric response data before and after the pumping test showed that there was a general downward movement of groundwater from the surficial sediments and through the overlying siltstone/claystone into the more permeable coal units.

Hydraulic conductivity values for lithologic units, while all low, have differences that might be related to formation facies variations and possibly to structural features such as faults and joints.

It is likely that for the weaker rocks the distribution of the clay fraction within the materials controls the hydraulic conductivity. Figure 5-5 shows the variations.

5.2.4.5 The Hydrogeological Picture of the Hat Creek Valley

From the work performed by Golder Associates, a reasonably clear model for the Hat Creek Coal Basin has emerged. The model can basically be divided into three hydrogeological units: the surficial deposits, the coal, and the sediments above and below the coal.

The surficials are highly variable, changing from predominantly slide debris and till on the West to gravels and fine sands on the East. There is a wide range within the hydrogeological parameters in this unit, with the alluvium in the valley bottom giving relatively high hydraulic conductivities. They constitute the major water-bearing units in the Hat Creek Valley.

The coal parameters are also variable and are not easily characterized. Falling head tests suggest that the B and D-zones are generally four orders of magnitude more permeable than the A and C-zones, possibly because of their generally lower ash content and greater development of structure. Although the single pump test (W-77-1) in the D-zone coal did not suggest good drainability, it has been assumed that these materials will be more drainable than the non-carbonaceous Coldwater sediments. A pump test (W-78-2) in the cleaner part of the A-zone coal has shown that this unit can be relatively easy to drain, at least in some areas.

The remaining Coldwater sediments (claystone/siltstone/conglomerate) have very low hydraulic conductivities and low consolidation coefficients.

The pre-mining water table surface generally parallels the topographic surface and is at or near the ground surface in the Hat Creek Valley. However, in places the piezometric surface is up to 100 m below ground on the Eastern side and above ground on the Western side of the valley. The flow systems are shown in Figure 5-6.

The Western bench slopes would not be well drained and groundwater discharge in the form of springs and seeps are common, particularly below the 970 m contour. This South-West perimeter of the pit frontage, with its overlying masses of inactive slide material, could become unstable again due to mining excavations.

Mining consideration has to be given to control of sliding, or potential sliding, by means of preventive rather than remedial action. Mine planning has to include considerable work to achieve control by two processes: drainage dewatering and unloading. The drainage has to be done as early as possible before mining starts. "Unloading" should be considered part of the overall mine planning when stripping and slope angles are being assessed; the degree of negative pore pressure response will become apparent after several years of mining have taken place.

5.2.4.6 Controls and Preventive Measures

1. The Mine Drainage Plan

Described in "Section 6.3.2.1, The Open Pit", this report deals with the diversion of Hat Creek and Finney Creek perimeter drainage, in-pit drainage, and dewatering wells.

In Section 6.3.2.2 the whole drainage scheme of the South-West slide area is described.

A more detailed document of the whole drainage system has been prepared by CMJV Consultants, which incorporates the Golder Associates' recommendations and findings. (Ref: "Hat Creek Project - Mine Drainage Report", CMJV, October 1979)

2. Pressure Control by Electro-Osmosis

In "difficult-to-drain" situations this method can be used to increase the factor of safety against failure by driving the water away from a face to a point where it can be pumped - e.g. a well.

An electric current is fed into the ground between two electrodes. The potential difference set up between the electrodes in ground of low hydraulic conductivity creates seepage pressures due to electro-osmotic flow, which directs water away from the anode to the cathode. The cathode can be constructed in the form of a well which can be pumped.

A test was carried out at Hat Creek at pump test hole #W 77-2.

Reductions in pressure of over 14 m head were achieved at the anode over a period of 20 days, and it was concluded that the technique could have some application at the site. The technique is mostly suited for stabilization of limited areas, because of the time and cost of the installations needed.

5.2.4.7 Evaluation of Piezometer Hydrographs

Hydrographs of 227 piezometers installed in 137 boreholes drilled in 1976-78 have been studied and are presented in Appendix 12 of Golder Associates' Report. The hydrographs are based on monthly readings in both standpipe and pneumatic piezometers. The following conclusions may be drawn from this analysis:

- (1) Standpipe piezometers installed in claystone units of low hydraulic conductivity are slow to respond. Basic time lags range up to six months;

- (2) The pneumatic piezometers are significantly more responsive; however, a reading resolution of ± 0.5 m with current read-out sensitivity reduces their capability to detect seasonal changes;
- (3) Most piezometers showed a slight rise (0.3 to 2 m) during the Fall and early Winter, and some shallow piezometers in more permeable rock zones showed a similar rise during the Spring melt in April to May;
- (4) Once the piezometers stabilized, the observed seasonal changes in piezometric levels appear to be less than 3 m for all but a few installations;
- (5) Piezometers in the more permeable surficial materials, with the exception of those close to watercourses, showed similar responses to those observed in the bedrock zones.

A longer period of recording will be necessary before a more definitive rainfall-recharge relationship can be determined. However, these hydrographs show that there are two periods during the year when groundwater recharge does take place, and, as expected, the seasonal changes in piezometric evaluations are very small.

5.2.5 Material Characteristics

5.2.5.1 General Description

The open pit will be directly concerned with the following four major types of materials:

| | | |
|-----------------|--------------------|--|
| Unconsolidated: | Surficial deposits | - glacio-fluvial sands and gravels; |
| | Slide debris | - breccia, volcanic debris, bentonite clays; |
| Consolidated: | Coal beds | - in-situ coal zones; |
| | Cold water rocks | - bedrock clay, waste rocks. |

A large number of identified rock types was consolidated into 10 principal categories of materials:

- (1) Clean coal;
- (2) Silty coal and shaley coal;
- (3) Carbonaceous shale and carbonaceous claystone;
- (4) Shale and claystone;
- (5) Silty claystone and silty shale;
- (6) Coaly shale and coaly siltstone;
- (7) Carbonaceous siltstone;
- (8) Siltstone;
- (9) Sandstone;
- (10) Conglomerate.

The strengths and geotechnical characteristics of these materials are dealt with in Section 5.2.3, along with concerns for slope stability and design slope angles. See also Tables 5-1 and 5-2.

In general, the open-pit mining of the Hat Creek No. 1 Deposit will be in relatively weak and soft rocks and overburden. The coal beds will be the strongest members of the whole strata of sedimentary beds intersected by pit excavations. However, even the coal beds cannot be considered as hard rock. The coal itself varies from hard to soft types, depending on how much clay is in it.

The other major factor inherent in the materials being mined is the moisture content of the materials. From the drilling programs, bulk sample excavations, and geological theory of deposition of the coal beds, it is known that all the materials will be saturated and almost non-drainable. Bench faces may develop a skin dryness, but this will probably only penetrate to a maximum of one metre after a year of exposure.

Climatic changes over Winter freezing and Spring thawing will affect material characteristics because of their high moisture content.

The bentonitic clay seems prevalent in a lot of the upper-zone interbed partings, especially in the West and South-West areas of the pit. This clay absorbs moisture, swells when wet, and becomes extremely sticky and slippery. Waste materials will react according to how much bentonite (montmorillonite) they contain.

The wet low-grade coal is generally mushy and weak in strength. This will cause problems in mining the A and C zones' benches.

5.2.5.2 Specific Gravity

In the course of the exploration drilling programs, specific gravity tests were conducted in 5,622 samples, using a variety of methods. This testing covered a large number of materials of both coal and waste.

The specific gravity test results, together with the ash and moisture determinations for the samples, were input to a computer data file. The data were retrieved from the file summarized by various classifications. For each case, cumulative frequency distribution curves were plotted and standard statistical parameters calculated: mean, standard deviation, standard error, and range. Scatter diagrams were produced in each case for ash vs. specific gravity, ash vs. moisture content, and specific gravity vs. moisture.

Examination of the scatter diagrams produced the following conclusions:

- (1) For coal and coaly materials, there is a distinct ash-specific gravity relationship;
- (2) There is no apparent difference in this relationship in the different coal zones;
- (3) In the higher ash range, there is some indication of a curvilinear relationship; however, with the scatter of the available data, this could not be confirmed;
- (4) There are no apparent relationships between moisture content and ash, nor between moisture content and specific gravity.

Since the distribution diagrams for coal demonstrated the same trend and overlapped, the plot with the least scatter that adequately represented the range (303 samples), was selected to establish the regression relationship:

$$\text{Specific Gravity (coal)} = 1.21104 + 0.00738 \times \text{Dry Ash\%}$$

(Correlation coefficient = 0.90510)

For comparative purposes, a second relationship was determined for 120 samples of shaly coal. This relationship produces very similar results to the first equation over most of the range, with a maximum difference of 2% at the extremes, which increases the confidence in the selected equation.

The specific gravity of the many types of waste materials does not lend itself to analysis and correlation. Based upon inspection of the data, the following were selected for use in the study:

Surficials and Waste Rock: Specific Gravity = 2.00

Burn Zone: Specific Gravity = 2.16

5.2.5.3 Swell Factors

The swell factors of three primary materials were studied and the results are as follows:

| | <u>As Mined</u> | <u>Dumped in Stockpiles</u> |
|-----------------------|---------------------|---------------------------------|
| Coal | 35% | 35% |
| Waste above bedrock | | |
| - Granular surficials | 20% | 15% |
| - Cohesive surficials | 30% | 25% |
| Bedrock waste | 30% | 25% |

Lacking site-specific measurements to derive swell factors for large-scale materials-handling activities, each planned waste dump was arbitrarily limited to approximately 75% of its recommended capacity. This would allow a safety margin should swell factors during actual operation be greater than those used in the study.

5.2.5.4 Material Cutting Resistance

Uni-axial compression tests and tri-axial shear tests were carried out to determine the cutting resistance of the various surficial and bedrock materials.

The average test results are shown on Tables 5-1 and 5-2. The same tables indicate the moisture content by type of materials, which exerts a major influence on the characteristics of mined materials and related equipment productivity.

5.2.5.5 Bearing Capacity of Materials

For the mine buildings and fixed structures generally, the in-situ strengths of both surficial materials and bedrock are expected to exceed the minimum specification of 5 kg/cm² for foundation support.

A study was made to determine the ability of roads to support large mobile equipment working at high production rates. Roads on granular surficial materials were considered to require minimal preparation, construction activities consisting of filling excavations or other hollows with adjacent materials to attain a uniform gradient, and providing for drainage. Normal road topping would be applied to the graded surface. Specific road-building technology is only considered necessary in the North-West slide area.

Roads on waste rock and in-situ coal are considered capable of supporting the traffic of 154-t trucks, provided an adequate sub-base is constructed. As the effective moisture in most of the bedrock materials is below the derived values for plastic limits, geotechnical conclusions indicate that heavy traffic is likely to compact rather than to liquify the materials.

The design of haul roads crossing the active slide area must take into account two problems: soil creep, and localized "boils" in the bentonite clays. The first problem requires construction of a higher standard sub-base and more frequent upkeep, resulting in higher localized road maintenance costs. The recommended solution to bentonite "boils" is simply to identify them prior to road building, and to avoid them.

5.2.6 Dilution and Mining Loss

No allowance is made for dilution and mining loss in this preliminary engineering study.

5.2.6.1 Dilution

In most mining studies it would be appropriate to make an allowance for accidental inclusion of waste materials mined with fuel-grade coal.

The mining approach recommended for the Hat Creek Coal Deposit stipulates that waste partings shall be selectively removed during mining when the thickness of these partings exceeds two metres. The quantity of diluents in the run-of-mine coal would therefore be a function of the surface area of the coal/waste interfaces and the attitude of these interfaces.

The sampling procedures carried out on Hat Creek drill cores have included significant quantities of waste material in the samples of good quality coal. The coal quality values used in mine planning evaluations have already been reduced due to this factor. In actual mining operations much of this included waste would be rejected. For this reason it was decided not to include any further allowance for the dilution of fuel-grade coal.

5.2.6.2 Mining Loss

Mining losses of the coal reserves could occur from the following day-by-day operating situations:

- (1) Coal lost when waste is removed at coal/waste interfaces;
- (2) Errors in dispatching coal to waste dumps;
- (3) Degrading of coal during ground sloughs to such an extent that it would be dispatched to the waste dumps;

- (4) Losses from dusting of fine coal and spillages during transportation.

When estimates are made of these potential losses of coal, they are found to constitute less than half of one per cent of the total coal mined. This parameter was therefore considered insignificant and not included in the preliminary engineering design.

5.2.7 Selective Mining

5.2.7.1 Definition

The Hat Creek coal deposits are unique, because of the immense thickness of the coal formation, which is due to the existence of a favourable depositional environment for an extended period of time. However, this period of coal deposition was frequently interrupted by episodes of flooding, which introduced non-carbonaceous sediments into the basin. These sediments produced waste partings, usually clay, in the coal sequence. The break between coal and clay is not generally sharp, but includes a transition zone which grades from good coal through a phase where the coal and clay materials combine to form a low-grade coal (silty coal), to a succeeding phase where the clay predominates (carbonaceous claystone), and finally to the clay.

These periodic inundations were particularly significant during the deposition of the A and C coal zones. The C-zone depositional environment appears to have been particularly turbulent, judging by the widespread occurrence of the lower grades of coal and the relative absence of substantial bands of good quality coal. In spite of its erratic history, it is still possible to identify seven separate occurrences of flooding within the C-zone. The A-zone was deposited in an environment that alternated between relative calm and severe flooding. This has resulted in bands of good coal interbedded with clay grading to coaly shale. Within the A-zone 20 of these interbeds, ranging in thickness from 2 m to 10 m, have been identified. The D-zone coal was deposited during a stable period. Few waste partings were formed and the best, most consistent quality of coal, is contained in the D-zone. The B-zone was also deposited under relatively stable conditions although there were a few incursions of sediment-laden floods to produce some waste bands.

Similarly, within the predominantly waste zones, there are occasional bands of acceptable coal.

The larger waste and low-grade partings are simple to identify and easily mined as waste material. The smaller partings, up to 5 m, are more readily mined with the coal. However, while this simplifies the mining process, it reduces the quality of the coal fed to the boilers, which are subjected to additional wear and produce larger quantities of ash to be disposed of.

The separation of these smaller partings from the coal would improve the boiler-fuel quality. This is the selective mining process.

Preliminary studies were conducted to assess the impact on coal quality of the exclusion of waste bands varying in thickness from $\frac{1}{2}$ m to 5 m. These studies indicated that significant improvements in fuel quality could be obtained with selective mining. This improvement would be particularly significant in the A-zone. In the C-zone the quality improvement would be small, but more coal would be recovered. Overall, the indications were that as much, or more, total heat content could be recovered depending on the size of parting that could be removed.

The results of these studies were reviewed from a practical and economic viewpoint. The two main conclusions drawn from this review were:

- (1) The mining method employed would govern the degree of selective mining that could be effected;
- (2) The cost of separating small waste bands ($\frac{1}{2}$ -1 m) would be high and reduce equipment productivity significantly.

5.2.7.2 Selective Mining Methods

Experience gained during the Bulk Sample Program excavating the coal with a hydraulic shovel established that this type of equipment can selectively mine Hat Creek coal. During this test program, a hydraulic shovel with a 3 m³ bucket was able to segregate partings 1 m thick. This separation is possible primarily because of the difference in the physical characteristics between the coal which is hard, and the partings which are soft. After exposure to the atmosphere for a week or

two, sufficient drying of the coal face occurs to highlight the colour differences between coal and waste. This assists in the identification of the different materials. Observation of larger hydraulic shovels with 10 m³ buckets at other mining operations indicates that the wrist-like digging action of these machines will permit selective mining of partings 1.5 m to 2 m thick without reducing equipment productivity. The hydraulic shovels have also proved effective in digging hard, rocky materials that cable shovels are unable to cope with unless the materials are blasted. The digging action of the widely used mining cable shovels severely limits their effectiveness in selective mining. Blasting is not compatible with selective mining because it loosens and mixes the coal and partings, destroying the physical differences that are essential to success.

Based on this evaluation of selective mining methods, it was concluded that partings 2 m thick and greater can be segregated effectively without significantly reducing equipment productivity or increasing mining costs. In practice, it will often be possible to mine selectively bands less than 2 m, depending on their position and attitude.

During operation, careful control must be exercised to ensure the success of selective mining. Closely spaced sample holes will be drilled ahead of mining, to permit local correlation of coal quality for short-term mine planning. This will be supplemented by detailed geological mapping of the exposed coal faces. Reject bands will be marked and face maps supplied to the shovel operators and their supervisors. These maps, together with the marked differences in the physical characteristics between the coal and waste, are expected to ensure the feasibility of selective mining. The results obtained will be monitored by a quality control group and by the product sampling and monitoring of the crushed product en route to the blending pile.

5.2.7.3 Selective Mining Evaluation

Several comparative evaluations have been made of the results obtained by selective and non-selective mining. Similar results were obtained in each case.

The results for a trial 35-year pit applying a 9.3 MJ/kg cut-off grade are:

| | <u>2 m Selective Mining</u> | <u>Non-selective Mining</u> |
|------------------|---------------------------------|---------------------------------|
| Coal-tonnes (Mt) | 347 | 365 |
| HHV - MJ/kg | 18.06 | 17.12 |
| Ash-content - % | 33.47 | 36.20 |

These results show that with selective mining:

- (1) The total heat content supplied to the boilers is a fraction of a per cent higher;
- (2) The HHV is 5.5% higher;
- (3) The total tonnes of ash fed to the boilers is reduced from 132 million tonnes to 116 million tonnes.

From these facts it is concluded that selective mining is beneficial because: it provides for good resource utilization; improves boiler operating efficiency; and will improve boiler reliability due to the significant decline in the quantity of ash handled. These benefits can be obtained without a significant increase in mining costs.

Recent developments in the interpretation of geophysical logs indicate that there are more coaly claystone partings in the deposit than were identified in earlier sampling programs or incorporated into the evaluation. This provides scope for further improvement in run-of-mine coal quality during operation.

5.3 MINING METHODS

5.3.1 Review of Alternatives

The following six alternative mining systems were identified:

- (1) Shovel/truck;
- (2) Shovel/truck/conveyor;
- (3) Shovel/conveyor;
- (4) Bucketwheel excavator/conveyor;
- (5) Continuous excavator/truck and/or conveyor;
- (6) Dragline/truck and/or conveyor.

From this list two systems were determined to be the most practical: The Bucketwheel Excavator/Conveyor System and the Shovel/Truck Conveyor System.

North American Mining Consultants (NAMCO) were retained to assess the feasibility of the Bucketwheel Excavator and Conveyor System for developing the deposit, while Cominco-Monenco Joint Venture (CMJV) carried out similar studies with the Shovel/Truck/Conveyor System.

In order to deliver a consistent fuel quality (heating value and sulphur) to the powerplant, the pit must be deepened rapidly during pre-production and the first 10 years of production. As a result, coal and waste mining will be carried out simultaneously on a number of working benches. The economic advantages of employing the Bucketwheel Excavator System in this type of operation are therefore not realized, and this system only becomes a practical alternative when most of the pit expansion occurs laterally.

Because of the minimal affect on the project cost, it was decided not to consider a change in the mining system from the Shovel/Truck/Conveyor System to the Bucketwheel Excavator System during the life of the project. It was also felt that this evaluation could better be made after some experience had been acquired with the recommended Shovel/Truck/Conveyor System. Since the recommended system has in-pit conveyors,

and the operating life of the major mining equipment is 10 years or less, it should be possible to have a smooth transition to a Bucketwheel Excavator/Conveyor System if such a change were found to be advantageous.

5.3.2 The Shovel/Truck/Conveyor System

As described in Section 5.4 ("Pit Design and Production Scheduling"), a series of incremental pits and a 35-year pit were developed by computer using the Dipper System, based mainly on economics. From these computer-generated data, and incorporating the design criteria described in Section 5.2, practical, operational pit plans were designed.

The selected scheme is a Shovel/Truck System in combination with an in-pit conveyor system. It includes a coal screening and crushing plant at the Northern end of the pit, and a coal stockpiling and blending facility from which blended coal is reclaimed and transported by overland conveyor to the powerplant. The low-grade coal (with a heating value ranging from 7.0 to 9.3 MJ/kg) is treated in a dry beneficiation plant with a capacity of 1,000 t/h. Beneficiation plant rejects are mixed with the mine waste in the Waste-handling System, while upgraded coal is conveyed to the blending facility.

Mine waste is transported by conveyor belts to Houth Meadows and Medicine Creek waste dumps and deposited by spreaders. Houth Meadows will be started in Year -1 by trucks and developed by spreaders in Year 1. Medicine Creek will be started by trucks in Year 12 and developed by spreaders in Year 15. Neither of the dumps will have been built to maximum capacity at the end of Year 35.

The mine service facilities are located at the Northern end of the mine and South of Indian Reserve IR-1.

All the foregoing are shown in Figure 3-3 (Detailed Site Layout Map).

The 35-Year Pit

Figure 5-17 shows the 35-year pit. It covers an area of about 5.4 km². The pit bottom is at elevation 662.5 m.

Significant features in the pit include:

1. Northern Exit

The mine plan developed shows multiple road access to the various benches. The in-pit conveyor and the principal roads exit to the North end of the pit.

Studies conducted to bring waste to Medicine Creek from a Southern exit showed that a causeway from the pit to the dump would interfere with the access road to the Upper Hat Creek Valley and, more importantly, with the Hat Creek Diversion. Long, large-diameter culverts under this causeway would need to be installed to make this scheme possible.

It was confirmed that the in-pit conveyor should exit to the North. The natural saddle of footwall waste between the two synclines provides an ideal location for the conveyor which would not entail additional mining of waste. An in-pit conveyor belt exiting South would require more waste to be mined to allow for an acceptable slope.

2. In-Pit Conveyors

A four-line, 1,500 m in-pit conveyor-belt system extends from 895 m elevation at the surface to 702 m elevation. A study of the number of mining benches and the corresponding hauling distances to the various delivery points confirms that the In-pit Conveyor System is essential for a more efficient hauling operation and the reduction of haulage costs.

3. Dump Stations

Three dump stations are located adjacent to the in-pit conveyor to which coal, low-grade coal, and waste material are delivered. The locations of the dump station were governed by the material distribution by bench and their corresponding average hauling distances.

Dump Station No. 1, at 887.5 m elevation, will handle material mainly from 1,045 m to 865 m benches inclusive; Dump Station No. 2, at 827.5 m elevation, material from 850 m to 775 m benches inclusive; Dump Station No. 3, at 722.5 m elevation, material from 760 m to 670 m benches inclusive.

These dump stations will be developed as mining progresses in depth and when hauling to existing pockets is neither practical nor economic. Based on computer-generated incremental pits and a study comparing haulage costs to the dump stations, the following schedule of installation was developed:

Dump Station No. 1 - Operational Year -1

Dump Station No. 2 - Operational Year 8

Dump Station No. 3 - Operational Year 20

The dump station design and road network complement each other. Material can be delivered and dumped either from the Eastern or Western sections of the pit. This feature simplifies hauling operations and reduces hauling costs.

4. Mine Roads

Mine roads vary in width from 25 m in coal, sand, and gravel to 40 m in the Medicine Creek and Coldwater formations. A 60 m-wide berm is provided adjacent to the active slide. This wide berm provides ample room for periodic clearing operations should soil creep occur.

The road network provides access at a minimum of two locations to each bench, usually on opposite sides of the pit. This operational feature will be important for two reasons: (1) it reduces hauling distances to the dump stations; and (2) it will provide better assurance of continuous mining should localized wall failures occur. The road network is designed to allow pit expansion after 35 years.

Three major berms are located at elevations 902.5 m, 827.5 m, and 722.5 m to coincide with the dump station elevations (902.5 m berm is one bench higher than Dump Station No. 1). During mining operations, access to the mining benches will be from these berms, which are essentially extensions of the dump stations.

5. The Pit Bottom

The pit bottom at elevation 662.5 m measures 700 m x 450 m at the widest dimensions and has an area of about 263,000 m². A secondary pit bottom, one kilometre long and 100 m wide, is at elevation 677.5 m. Both of these bench bottoms are totally in coal which has a wide range of heating value. Some eight million tonnes of coal can be mined by deepening the pit bottom without additional waste removal. This coal provides assurance that the designed pit can meet the powerplant requirements over the life of the project.

Mine Development

Mining is initiated on six benches west of Hat Creek and bounded by co-ordinates 5625200 N in the North, 5624700 N in the South

and 598400 E in the West. The pre-production pit is connected to Houth Meadows Dump by a 2.5 km temporary surface road at 880 m elevation. Prior to the installation of the conveyor system all construction materials will be used for road construction. Unsuitable materials are hauled by truck to Houth Meadows and dumped to 880 m elevation.

Excavation for Dump Station No. 1 will be started during pre-production in order to have the station operational in Year -1. The reasons for starting the first dump station early are threefold:

- (1) To reduce haulage distances from the pit to the dumps;
- (2) To assure the supply of approximately one million tonnes of coal to commission the powerplant in Year -1 (truck haulage to the powerplant for this quantity is impractical);
- (3) To have a source of sand and gravel for construction in and around the mine areas. Approximately three million bank cubic metres of sand and gravel will be mined from Dump Station No. 1 during pre-production.

A temporary 1.5 km surface road at elevation 887.5 m connects Dump Station No. 1 with the pre-production pit.

Figures 5-12 to 5-17 show pit development in various stages.

The mining sequence adopted shows that, during the early years, production is concentrated along the Eastern limb of the main syncline which has a wide range of calorific value. Mining of the thick sand and gravel beds overlying the North-East sector of the deposit is limited at this time. By developing the pit this way during the early years, the average heating value is maintained and a low stripping ratio is achieved.

In later years, as the mine develops in depth, the lower quality coal in the Western limb is exposed on the upper benches. By this time, sufficient sand and gravel will have been removed to allow mining of the higher grade coal in the Eastern syncline. This mining strategy ensures that both the average coal quality and the stripping ratio will be maintained at reasonable levels.

The pre-production pit starts almost at the centre of the deposit and expands progressively towards the final wall. This development sequence will provide ample time to observe pit walls and prepare

adjustments in pit design if required. The road network in the incremental pits is designed to provide enough flexibility to accommodate a revision of the pit design.

In the incremental pits, the coal benches were laid out so that coal could be mined from them at any time without having to mine the bench above. This ensures that a wide variety of coal quality will be available for blending. In sections located in waste, three to four benches were grouped together with the uppermost bench minable. Each succeeding bench becomes minable as the bench above it is mined out. This scheme was adopted to reduce waste stripping. Figure 5-3 ("Pit Slopes") shows the systems described.

Temporary roads between benches are limited. The intention is to construct and use the final haul roads as soon as it is practicable.

The excavation and installation of Dump Stations No. 2 and No. 3 is governed by the mining schedule of the various benches. This results in material being hauled from the two benches above and the three benches below the dump pocket elevation. The haul roads are designed accordingly.

5.4

PIT DESIGN AND PRODUCTION SCHEDULING

Pit design and production scheduling were performed, making extensive use of computer software developed by Mintec Inc., supported by manual mine planning techniques. This section describes the methods employed to perform the work starting from the Variable Block Model (VBM) developed earlier (described in Section 4.6) to the completion of the production schedule.

5.4.1

Planning Data

A set of cross-sections and bench plans for the coal deposit were produced to provide a clear picture of the structure and the spatial distribution of coal quality.

The preparation of the cross-sections from the Variable Block Model was straightforward. Each cross-section in the model was computer-plotted showing the geological sub-zones (see Figure 5-9) and the reserve blocks together with the tonnage and heating value for each block.

The preparation of the bench plans was more complex, because the VBM was constructed on cross-sections. The plans were ultimately produced by manually adjusting the computer plots. The adjustments required were primarily in areas of structural complexity and where sub-zones terminated between sections. The bench plans were produced for the mid-points of 27 benches at 15 m intervals. Each sub-zone block was annotated with an identification number, its coal tonnage, heating value, and waste quantity. These plans and sections were colour coded by heating value range for easier use in mine planning (see Figure 5-10).

5.4.2

The Dipper System

The Dipper System is designed to assist the mining engineer to develop mine plans and production schedules quickly. This

permits the evaluation of many alternative mining sequences in the time it takes to develop a single plan manually and results in a more practical and economic mine plan.

The Dipper System is designed to operate using a rectangular block model of the deposit. The blocks used for the evaluation of the Hat Creek Coal Deposit are 50 m square in plan and 15 m high. A block of coal this size represents approximately 55,000 t. Smaller blocks can be used to refine the pit design and production schedule, where warranted, by closely spaced data, at the expense of increased computer time. The model defines the mining area using 196,000 blocks. For each block the waste volume, coal tonnes, and heating value were calculated from the Variable Block Model. These calculations are made every 10 m, and the resulting composite values accurately reflect the geological interpretation and quality data for each block. The surface topography was digitized and input to the Dipper Model.

To permit the evaluation of alternatives, a value function is required. A gross value is assigned to each block based upon its total heat content. This gross value is reduced to a net value by the deduction of variable assigned overhead and mining costs for use in pit design.

The mining geometry in Dipper is simulated by a series of inverted, truncated cones. Each cone is defined by the base radius, which is equivalent to half the minimum mining width, and the slope, which can be varied in up to nine specified directions to reflect varying pit slopes. The centre of each cone coincides with the centre of a block. Any block whose centre is within the cone generated is included in the volume mined.

The design of the pit is controlled by the requirement to meet certain criteria. Typical parameters that can be varied in applying the Dipper System include:

- (1) Mining cost;
- (2) Minimum average heating value for each cone;
- (3) Maximum stripping ratio for each cone;
- (4) Required coal tonnage in a pit increment.

When these criteria have been specified, the pit limits are determined by evaluating the cones within the boundaries defined by the engineer. The parameters of all blocks contained by a cone are

accumulated and the results tested against the criteria. If the criteria are met, the cone is mined, and the process is repeated for another cone until the required tonnage is mined or no further cones meet the criteria.

Data displays available include:

- (1) Printer plotted symbol maps of the deposit by section and bench;
- (2) Symbol maps showing the pit limits on each bench;
- (3) Tabulated summaries of reserves.

5.4.3 Pit Design

The Dipper System's pit design capabilities were tested by developing a sequence of incremental pits to produce 347 million tonnes at an average heating value of 18.0 MJ/kg. The final pit bottom had moved about 200 m South compared with earlier manually designed pits; the stripping ratio was significantly reduced in the early years, with only a small improvement in the overall stripping ratio. The Dipper results were checked against cross-sections, bench plans, and previous designs in order to evaluate the differences. After checking, it was concluded that the results of the test were reasonable and that the system should be adopted for the pit design work.

Further tests were performed in order to remove concerns about the validity of the costs assigned and also to try to improve the coal quality in the first five years of operation. The cost parameters were varied in a series of runs, and it was found that the relative economics provided a sound basis for the design of a sequence of "best" pits. The coal quality improvement tests demonstrated that the objective could be achieved, but would result in an extended period of unacceptably low quality fuel later. This was a valuable exercise in demonstrating the speed and flexibility of the Dipper System.

In applying the system to the design of the overall pit slope angles were established in four directions: East 20°, South and West 19°, and North 15° (to allow for the conveyor ramp - see Figure 5-11). These overall slopes were determined from manually designed pits, which reflected the geotechnical constraints and incorporated mine haul roads. In the initial runs the minimum average heating value for

each cone was set at 17.0 MJ/kg and the maximum stripping ratio at 2.0. In subsequent runs these parameters were varied to force desired improvements in the plan.

The required coal tonnage in a pit increment was set at approximately one year's production for the first 10 years, and in five-year segments thereafter. In designing the interim pits, a flatter working slope (16° except to the North) was used.

The pit is designed one increment at a time until a final pit is reached which provides sufficient tonnage of an acceptable quality. When a satisfactory final pit was established, a pit design was prepared manually to incorporate roads, crusher stations, and conveyorways. The interim pits were then re-worked to modify the quality or stripping ratio. In this fine tuning process, the pit design can also be forced to excavate material in a particular area to permit installation of required facilities.

The results for the 16 incremental pits developed are presented in Table 5-4. In arriving at this final series of pits, a total of 92 increments were examined to ensure the production of a consistent quality of fuel and to reduce the fluctuations in the stripping ratio.

5.4.4 Production Scheduling

At this stage of a project production scheduling would not normally be carried beyond the stage reached with the completion of the sequence of interim pits. However, in the case of the Hat Creek Project it was considered necessary to ensure that the larger, five-year increments did not include extended periods where only unacceptable quality fuel was available.

Working within the incremental design pits, production scheduling selects the coal to be mined in a given time period. This is accomplished by examining the pit bench by bench from the top down, removing the coal until the production requirements are met, and identifying the waste that must be removed to permit mining that coal. This process is repeated for succeeding years until all the coal in that pit increment is mined. Scheduling then continues from the next increment and progresses until the pit is mined out.

This preliminary production schedule showed a wide fluctuation in the quantities of waste removal for each year. To ensure a practical mining operation that makes efficient use of the equipment available, these fluctuations must be smoothed out. This smoothing was achieved by establishing the annual waste production capacity and forcing advanced waste removal in low stripping years. This procedure was effective, and a practical production schedule was produced that maintained an acceptable quality of fuel and balanced material quantities over the life of the project.

Initially, the production schedules were developed based on an annual coal tonnage requirement at an average quality. The resulting schedule showed that the total heat content of the coal produced in a given year deviated from the powerplant requirements. To overcome this problem the production was rescheduled to deliver the required total heat content.

The Adjusted Production Schedule (Table 5-5) shows the final production schedule that was produced by this process. A final manual adjustment was made to this schedule to incorporate waste removed outside the pit limits for the development of facilities (Table 5-6).

5.5 WASTE DUMPS AND EMBANKMENTS

5.5.1 General

The total amount of waste material mined from the pit over its 35-year lifespan would be 426.8 million bank m³. Two areas have been selected where the waste could be safely and economically dumped: (1) Houth Meadows, at the North-West rim of the pit, with a maximum capacity of 542 million m³ or about 439 million bank m³; (2) Medicine Creek, about one kilometre South-East of the pit, with a capacity of 257 million m³, with the crest at 1,130 m elevation. The potential exists for Medicine Creek to be raised to 1,200 m elevation which would increase the capacity by another 310 million m³ for mine waste and ash.

The selection was based on proximity, capacity, geotechnical characteristics, and topographical and geological features which render both dumps capable of meeting the most stringent requirements. Another significant factor was the possibility of expanding the 35-year pit to mine out the No. 1 Deposit and starting to mine the No. 2 Deposit to the South.

Comprehensive studies were undertaken by Golder Associates, geotechnical consultants, and their recommendations incorporated into the design of the dumps (see Section 5.5.2). B.C. Hydro's own geotechnical engineers have reviewed the consultants' work, and have issued a report "Memorandum on Proposed Waste Disposal Embankment Studies", dated October 1979. Section 7 of their report, Conclusions and Recommendations for Final Design Studies, is shown in Section 5.5.6.

5.5.2 Geotechnical Constraints and Parameters

5.5.2.1 Material Parameters

Tests have led to establishing two general categories of waste:

- (1) Unstable and very weak bentonitic claystones and siltstones, and weak silty and clayey sedimentary deposits. These materials would remain in an unconsolidated condition for many years, and their shearing resistance would be that of a partially saturated material in an undrained condition. They will therefore need to be retained by well-engineered embankments;
- (2) Stable and relatively stronger material consisting primarily of sand, gravel, and till. These materials are suitable for embankments as well as for construction of roads, yards, and as concrete aggregate.

5.5.2.2 Parameters of Waste Dumps and Embankments

Geotechnical tests and studies were concerned with three main issues related to dump stability:

- (1) The stability of retained waste;
- (2) The stability of retaining embankments and their foundations;
- (3) The gross interaction of waste dumps and pit slope excavations.

1. The Stability of Retained Waste

As the dumps must be considered on the basis of long-term stability at maximum capacity, they must be located in relation to the walls of the ultimate pit. Field and laboratory tests were performed, including an examination of the characteristics and stability of a trial waste dump on site. From these it was concluded that the retained waste can be kept stable, whether saturated or unsaturated by keeping it within the recommended surface slope of 5%. This slope could be increased as more experience regarding slope stability is gained.

2. The Stability of Retaining Embankments and their Foundations

The embankments must be free-draining and constructed entirely of well-graded and fairly clean sand and gravel. To remain stable, they must be uncontaminated by bentonitic clays, and be designed with a safety factor to hold the retained waste when either in a saturated or a fluid state. The recommended overall slopes for the embankments are 2.5 horizontal to 1 vertical on the outside face, and 1:1 on the inside face.

3. The Gross Interaction of Waste Dumps and Pit Slope Excavations

The Houth Meadows Dump is sufficiently close to the pit for the stability of the dump and the pit slope to be considered as a unit. A North-East to South-West-trending conglomerate ridge has been identified West of the pit. This would form a buttress and provide additional support to the dump.

The Medicine Creek Dump is far enough from the 35-year pit but would be within 600 m from the pit rim of an ultimate, or total resource, pit. Investigations were conducted on the basis of the total resource pit from the CMJV report rather than the 35-year pit. Present studies indicate that the sequence of granular rocks underlying the Medicine Creek embankment would provide adequate long-term support to the proposed dump.

5.5.3 Construction and Development

Although both Houth Meadows and Medicine Creek dumps at maximum capacity can accommodate the total 35-year mine waste, it is recommended that neither dump should be built to capacity until more data is available. Material characteristics relating to swell factors are uncertain and can only be ascertained during actual operations. Room for additional waste will also be required for any expansion of the pit. Neither the Southern end nor the bottom of the No. 1 Deposit will have been mined out after Year 35.

Of the two dumps, Houth Meadows will be the first to be constructed. It will be developed at a full rate from Year 1 to Year 14 by two conveyor-spreader systems, each working in 35-m lifts. From Year 12 to Year 14, haulage trucks will lay the foundations of the Medicine Creek Dump in preparation for one of the conveyor-spreader systems which will be transferred from Houth Meadows. From Year 15 onwards, both Houth Meadows and Medicine Creek dumps will be constructed concurrently. Figure 5-18 shows the different stages in the development of each dump. This sequence of dump development is geared not only to the most efficient exploitation of the No. 1 Deposit during the 35-year project life, but takes into account the possible expansion of the No. 1 Deposit and/or future mining of the No. 2 Deposit. It also allows ample time to study the effects of accumulating large amounts of waste in the dumps.

The development sequence for each 35-m lift is divided into three phases:

5.5.3.1 Construction of Access Roads and Initial Conveyor Pads

Conveyor pads will be constructed at the far end of the dump from the retaining embankment at an elevation 20 m above the existing dump surface in that area. Access roads and conveyor pads will be constructed on contour using sidehill cuts to the extent practical. Conveyor pads will be 40 m wide, which is sufficient for the installation of the shiftable conveyors and initial operation of the spreader.

The access roads and conveyor pads will be built with glacial till, sand, or gravel. Road construction equipment: front-end loaders, 32-t trucks, dozers, graders, and compactors, will be used for this job. This equipment will also be used for filling areas inaccessible to the spreaders.

5.5.3.2 Dumping General Waste

The spreader will start dumping waste from the initial conveyor pad. The first spreading pass will be on the downhill side of the conveyor, where a 20-m lift will be placed bringing the filled area up to the elevation of spreader tracks. This lift will be levelled and its surface compacted by bulldozers to prevent moisture penetration. This operation continues until the spreader has completed placing the lower lift. The spreader is then relocated to the uphill side of the shiftable conveyor, where it places a 15-m lift of waste above its operating elevation. When this upper lift is completed, the shiftable conveyor is moved towards the embankment on top of the previously placed 20-m lift. The new location for the conveyor is not closer than 25 m to the crest of the fill.

The cycle is then repeated with the placing of the lower 20-m lift, then the upper 15-m lift, followed by advancing the conveyor. This process continues with general mine waste until the Conveyor-spreader System reaches the upstream face of the embankment.

This system is illustrated in Figure 8-7.

5.5.3.3 Construction of Embankments

When the Conveyor-spreader System reaches the embankment, the operation continues in the same manner, but the materials transported and placed must be the approved construction materials: sand and gravel uncontaminated by bentonitic clays. On completion of the embankment section of the 35-m lift, the face of the embankment must be trimmed to the designed 2.5:1 slope ready for revegetation. The shiftable conveyor system is dismantled and re-erected on a new conveyor pad constructed at the planned elevation of the next lift.

This dumping sequence prevents the ponding of water between the general mine waste and the embankment. Routine grading of the dump surface and ditching will be required to collect surface runoff and direct it into the main drainage treatment and disposal system.

Tables 5-7 and 5-8 show the capacity by lift of the Houth Meadows and Medicine Creek dumps and the construction schedules.

5.5.4 The Houth Meadows Waste Dump

Development of the Houth Meadows Dump will start in about Year -1 after the causeway for the Main Transfer Conveyor has been built. Prior to the construction of the dump, the base will be prepared by laying free-draining sand and gravel material for drainage and constructing a leachate collection facility at the toe of the embankment.

Waste from the pre-production pit, and sand and gravel from Dump Station No. 1, will be hauled by trucks. These will be used to build the dump to the 880 m elevation. In the meantime, the road construction equipment will be constructing the first transfer and shiftable conveyor pads at the 900 m elevation. Conveyor-spreader System No. 1 will be installed at this elevation so that waste can be dumped to the first 35-m lift (between the 880 m and the 915 m elevation) in Year 1.

The second transfer and shiftable conveyor pads at the 935 m elevation will be built after the 880-915 m lift has advanced far enough to allow space for construction. Conveyor-spreader System No. 2 will be installed at the 935 m elevation and dumping of waste to the second lift (between the 915 m and the 950 m elevation) will commence in Year 2. Both of the conveyor spreader systems will then work concurrently, in parallel.

Following the two bottom 35-m lifts, the schedule for the succeeding lifts is:

- (1) Construct transfer and shiftable conveyor pad at 970 m elevation in Year 5; relocate Conveyor-spreader System No. 1 from the 900 m elevation; commence waste dumping in Year 6. Upon completion of this lift in about Year 14, the conveyor and spreader will be transferred to Medicine Creek;
- (2) Construct a transfer and shiftable conveyor pad at the 1,005 m elevation in Year 8; relocate Conveyor-spreader System No. 2 from the 935 m elevation and commence waste dumping in Year 9. The 985-1,020 m lift will be completed in about Year 22;
- (3) Construct a transfer and shiftable conveyor pad at the 1,040 m elevation in Year 22; relocate Conveyor-spreader System No. 2 from the 1,005 m elevation, commence waste dumping in Year 23 and carry on the operation until Year 35. A total of 305 million m³ will be dumped in Houth Meadows from Years -2 to 35. A further 134 million m³ could be placed in this area if required.

Houth Meadows is designed with the ultimate embankment crest at the 1,005 m elevation. The major embankment runs from the hill by the Hat Creek road - Lillooet Highway junction to the NE-SW-trending conglomerate ridge. Three minor embankments are located running in an East-West direction and are required to prevent waste from flowing on to the Lillooet Highway. As recommended by the geotechnical consultants, the dumps are designed with a 2.5 horizontal to 1 vertical on the outside face and 1:1 on the inside face of the embankment. Figure 5-21 shows the waste dumps slopes.

The retained waste dump is designed sloping at a 5% grade from the crest of the embankment at the 1,005 m elevation to the Westernmost limits at the 1,150 m elevation. The surface area of the dump covers approximately 580 ha at maximum capacity.

Surface water in the dump area will be collected by a suitable drainage system around the perimeter and surface runoff will ultimately be collected in the settling ponds. Figure 5-19 is a detailed drawing of the Houth Meadows Waste Dump.

5.5.5

The Medicine Creek Waste Dump

Development of Medicine Creek Waste Dump will commence in Year 12, three years before the installation of the Conveyor-spreader System. Contractors will prepare the base of the dump by laying free-draining sand and gravel material for drainage, and will build the narrow portion of the dump up to the 1,040 m elevation by trucks. Approximately 9.4 million bank m³ will be hauled by the contractors over a temporary road. By the end of Year 14, construction work should have been completed. The dump will then be built using Conveyor-spreader System No. 1, which will be transferred from the Houth Meadows Dump.

The dump development sequence is as follows:

- (1) Truck construction: base of dump to the 1,040 m elevation from Year 12 to Year 14, by contractor, using haulage trucks;
- (2) Construct transfer and shiftable conveyor pads at the 1,060 m elevation in Year 14; relocate Conveyor-spreader System No. 1 from Houth Meadows Dump in Year 15; dumping of waste 1,040-1,075 m lift from Year 15 to Year 18;
- (3) Construct transfer and shiftable conveyor pads at the 1,095 m elevation in Year 17; relocate Conveyor-spreader System No. 1 from the 1,060 m elevation in Year 18; build 1,075-1,110 m lift from Year 18 to Year 26;
- (4) Construct transfer and shiftable conveyor pads at the 1,130 m elevation in Year 25; relocate Conveyor-spreader System No. 1 from the 1,095 m elevation in Year 26; build 1,110-1,145 m lift from Year 26 to Year 35.

A total of 113 million bank m³ of waste will be dumped in Medicine Creek from Year 15 to Year 35. About 29 million m³ capacity remains below the 1,130 m crest.

From Year -1 to Year 14, while dumping of waste will be in Houth Meadows, ash from the powerplant will be deposited at Upper Medicine Creek (downstream of the water reservoir dam). Ash deposition will progress downstream while dumping of waste will progress upstream. At about Year 20 or Year 21, the two disposal systems will meet. At this time, waste material will be dumped at a slope of 2.5 horizontal to 1 vertical at the interface between the waste and the ash. By doing so, ash will overlay the waste as both are built up. Figure 5-20 is a detailed drawing of the Medicine Creek Dump.

Following the geotechnical consultants' recommendations, the retaining embankment is designed at 2.5 horizontal to 1 vertical at the outside face and 1:1 in the inside face. The retained waste slopes at a 5% grade from the crest of the embankment to the interface with the ash, after which the latter slopes at 1% up to the water reservoir dam (see section detail Figure 5-20). The Northern side of the waste dump forms a V-cut with the hillside to permit access to the reservoir overflow outlet conduit which carries any overflow from the reservoir down to the Hat Creek Diversion Canal.

Canals around the perimeter of the dump will be installed to collect surface runoff. Runoff from the dump surface will be diverted to the settling ponds West of the embankment.

5.5.6 Conclusions and Recommendations Relating to Waste Disposal Embankment Studies

The geotechnical consultants' studies and the recommended design basis for the waste disposal embankments were reviewed by the B.C. Hydro Hydro-electric Generation Projects Division. They presented the following conclusions and recommendations in their design memorandum:

5.5.6.1 Conclusions

It is concluded that the studies are complete and adequate for the preliminary design stage. The design for the retained waste material disposal and the stability of the retaining embankment and its foundation have an acceptable factor of safety for static conditions. The analysis for interaction with total resource pit slope is reasonable.

5.5.6.2

Recommendations

For final design studies it is recommended that:

- (1) An exploration program be carried out at the proposed Medicine Creek retaining embankment to confirm either that siltstone and claystone do not exist in the foundation, or that they do not affect the stability of the retaining embankment;
- (2) The stability of waste dump and pit slope of the Houth Meadows Dump be studied further, if the total resource pit scheme is to be adopted;
- (3) Tests be carried out to assess the proposed method for compaction (i.e. by impact of gravels falling from conveyor belts) of the embankment fills;
- (4) The embankment and waste mass be analyzed for seismic stability and that the sands in embankment foundation be evaluated for liquefaction potential.

TABLE 5-1

DESCRIPTION OF SURFICIAL MATERIALS

| TYPE | DESCRIPTION | LOCATION | RANGE OF HYDRAULIC CONDUCTIVITY m/sec | GEOTECHNICAL COMMENTS | MOISTURE CONTENT OR DRY WEIGHT BASIS | UNIAXIAL STRENGTH | ATTERBERG LIMITS |
|-------------------------|---|--|--|--|---|--|--|
| Till | Glacial deposit composed of cobbles and gravels with occasional boulders up to 1 m dia. maximum but generally much less, in a matrix of sand, silt and clay. Locally variable, depending on matrix. Seen in base of Clay-Cut. | West and southeast sides of valley | 10 ⁻¹⁰ -10 ⁻⁸ | Generally dense or compact, boulder size may locally inhibit digging although usually will be able to be dug by hydraulic excavator. Where gravelly, may make water. | 15% - 50% Average 26% | 0 - 300 kPa | LL = 86 PL = 42 (avg. from a small number of tests) |
| Lacustrine Deposits | Bedded silts, silty sand with coarse sand and occasional gravel may be also clayey, laminated and/or highly disturbed. Overconsolidated. Glacial origin. | Locally through-out glacial deposits. Houth Meadows embankment foundations. | 10 ⁻⁷ -10 ⁻⁶ | Unusually dense. Where laminated, easy to dig but uniform heavily overconsolidated silts of Houth Meadows could give difficulties. Surface materials in Dry Lake and Houth Meadows are soft. | 18% - 32% Average 25% | 200 - 500 kPa | LL = 48 PL = 26 (avg. from a small number of tests) |
| Glacio-fluvial Deposits | Interbedded rounded-sub-rounded sands and sandy gravels with cobbles and boulders up to 0.7 m dia. (approx.). Much variation in grading. Some interbedded tills. Glacial meltwater deposit. | East side of valley, locally on west also. | 10 ⁻⁷ -10 ⁻⁵ | Dense, possibly slightly cemented, free draining. Will not generally present digging problems. Boulder size smaller than till. Rounded materials. Some ironpans present. | Depends on drainage | non-cohesive | Non-plastic |
| Colluvium | Coarse, angular, roughly bedded perhaps with variable proportion of fines formed on slopes by erosion. May comprise volcanics, limestone or granodiorite. | Widespread at base of steeper slopes. | 10 ⁻⁷ -10 ⁻⁴ | Variable depending on local rock type. Angular, abrasive, maximum rock size large although generally gravel to cobble sizes. Free draining, locally unstable during digging. | 11% - 60% Highly dependent on composition average 30% | 100 - 500 kPa, depending on composition | Varies over full range because of composition variability. |
| Slide Debris (Stable) | Composed of variable assortment of glacial and glacio-fluvial materials Coldwater sediments and granodioritic material often in a bentonite matrix. Seen in upper part of Trench A and Clay-Cut. Mostly post glacial. | West side of valley especially NW. | not known | Variable. Generally moderately dense. Handling characteristics similar to Clay-Cut material. | 11% - 60% Highly dependent on composition average 30% | 100 - 500 kPa, depending on composition. | Varies over full range because of composition variability. |
| Slide Debris (Active) | As above, but some softer zones. Currently unstable. | Active slide in NW and minor slides elsewhere in W. | not known | Broken locally softened and weak rock probably sticky. Some seepages. Contains some proportion of gravel. Could give some handling and trafficking problems. Occasional boils. | 11% - 60% Highly dependent on composition average 30% | 100 - 500 kPa, depending on composition. | Varies over full range because of composition variability. |
| Alluvium | Rounded sands and gravels probably with silt interbeds as seen in Trench B. Mostly reworked glacials. | Predominantly in Hat Creek Valley bottom. | 10 ⁻⁶ -10 ⁻⁴ | Generally loose and free draining. Maximum size say 0.4 m. Gravel subsidiary to sand. | Depends on drainage | Usually not cohesive | Usually non-plastic but could go up to about LL = 40, PL = 15 (no test results). |
| Burn Zone | Varies from an irregular mass of red-brown partly-fused claystone and siltstone with some coal to well bedded slightly baked in situ Coldwater materials. | Dry Lake area. May be obscured by glacial or slide deposits in subcrop on W. side. | highly variable | Hard abrasive generally breaking up into gravel sized fragments, easy to dig. Difficult or impossible to dig where completely fused (as in part of Trench A). Some blasting locally necessary. | Insufficient data for characterization; properties highly variable. | | |

TABLE 5-2
DESCRIPTION OF ROCK MATERIALS

| TYPE | DESCRIPTION | LOCATION | RANGE OF HYDRAULIC CONDUCTIVITY m/sec | GEOTECHNICAL COMMENTS | MOISTURE CONTENT ON DRY WEIGHT BASIS | UNIAXIAL STRENGTH | ATTERBERG LIMITS |
|-------------------------|---|--|--|---|---|---|--|
| Claystone/ Siltstone | Very weak to moderately weak clayrich rocks in which bedding often hard to discern. Rock breaks along joints. Where softened or reworked, material highly plastic and tenacious. Zones of shearing and brecciation. Possibly tuffaceous near margins of basin. Generally dark grey or dark brown colour. Distinct tuff bands present. | Stratigraphically above the coal (Unit Tcu). Subcrops in an arc from NE to SW in final pit slopes. | 10-12-10-10 | Should be considered as a hard clay rather than a rock for excavation purposes. Easily dug where joints are present. Very uniform beds may be troublesome to hydraulic excavator. Handling and trafficking problems will occur in wet conditions due to presence of montmorillonite. Only slakes where sheared or brecciated. | 13% - 32% Average 24% May tend to decrease with depth from 29% at subcrop to 16%, 150 m deeper. | 400 - 12,000 kPa Average 3,700 kPa May tend to increase from 1,000 kPa to 8,000 kPa after 150 m. | LL = 95 PL = 35 (average) |
| Siltstone/ Sandstone | Interbedded siltstone and sandstone with subsidiary conglomerate, claystone and coals. Generally light grey in colour, highly anisotropic but bedding planes often difficult to find. Much facies variation. | W and NW pit slopes. Stratigraphically below the coal. Also occurs as interbeds in the conglomerate. | 10-11-10-10 | Should be considered as a stiff clay rather than a rock for excavation purposes. Easily dug where joints are present. Handling and trafficking problems will occur in wet conditions due to presence of montmorillonite. Dispersive, highly erodible, will form gullies, and sub-surface cavities. Slakes readily. | 23% - 70% Average 31% | 600 - 3,500 kPa As interbeds in conglomerate, 3,500 - 7,000 kPa | LL = 143 PL = 34 (average) |
| Sandstone | Varies from weak silty sandstone through to moderately strong fine grained conglomerate. Matrix usually composed of silt/clay and granular material may be tuffaceous and weak. Locally cemented especially immediately below the coal. Generally greenish. | W and NW Pit slopes. Stratigraphically below the coal. Forms interbeds in Lower siltstone/sandstone (Unit Tc1) and in conglomerate (Unit Tco1). | 10-10-10-9 | Generally weak rock whose excavation characteristics may differ little from the siltstones. Some trafficking problems as material breaks down. Often highly bentonitic. Characterized by west face of Trench A. | 19% - 32% Average 25% | Some tendency to increase from 1,000 kPa at surface to 10,000 kPa at 300 m depth. Interbeds in conglomerate range from 3,500 kPa to 10,000 kPa and vary similarly with depth. | LL = 80 PL = 30 (based on only a few results) |
| Conglomerate | Highly variable in character depending on relative proportions of granular material and matrix. Coarse gravel fragments rounded to sub-rounded but also angular where tuffaceous. Matrix may be bentonitic. Often calcite cemented. Not yet seen in outcrop or excavation. Contains interbeds of siltstone and sandstone. | S abutment of Houth Meadows Embankment. Forms ridge between Houth Meadows and pit (Unit Tco1). Also occurs as interbeds in Lower siltstone/sandstone (Unit Tc1) and at base of whole sequence (Unit Tco2). | 10-10 | Harder and more abrasive to dig. Where weathered could be disaggregated and behave as gravel. Will break down with much rehandling except where cemented. Calcite cemented conglomerate could not be dug without blasting. | Average 15%, based on few test results. Note that interbeds will raise overall average. | Depends on cementation; up to 43,600 kPa has been measured locally. Some zones almost uncemented. | LL = 60 PL = 27 (based on very few results) |
| Coal | Thinly bedded moderately strong but highly fractured. Interbedded with siltstone partings and beds, often highly sheared. Some cleating. Much variation from clean to dirty coal except in D-Zone. Some zones of complete fragmentation. | Centre of pit and limited area in SW wall. | 10-11-10-6 | Easily dug due to multitude of weak joints and partings. Bench failures common especially where bedding unfavourably oriented. Seepages from face, generally no sizable water inflows. | See DCA report | 1,000 - 17,000 kPa | See DCA report |
| Coal Interbeds | Generally thinly bedded claystone/siltstone of moderate plasticity. Some bentonitic material in A-Zone and near margins of basin. May be highly sheared or brecciated. | Centre of pit and limited area in SW wall. | 10-12-10-10 | Easily dug and similar to coal in some respect although will not break up as much. Impermeable locally softened. Thinner beds may be difficult to separate from coal. | 12% - 36% Average 23% | No data | LL = 59 PL = 33 (average) |
| Volcanics | Includes an assortment of basalts, dacites, rhyolites, agglomerates, breccias and tuffs. Closely jointed. | E and W of pit. | 10-11-10-6 | May require blasting or ripping. Generally hard and abrasive. Permeable. Generally drained. | No data | Up to 23,000 kPa has been measured. Strength may often be much greater. | N/A |
| Limestone | Massive or brecciated limestone with phyllite interbeds. | Underlying Houth Meadows. | 10-9-10-4 | Will require blasting. Generally strong phyllite bands weaker. Dry. | No data | No data | N/A |

TABLE 5-3

HYDRAULIC CONDUCTIVITY RESULTS

| LITHOLOGIC UNIT | | NUMBER OF TESTS | HYDRAULIC CONDUCTIVITY RESULTS FROM FALLING HEAD TESTS (m/s) | | | PUMPING TEST RESULTS | |
|--|--------|-----------------|--|----------------------|-----------------------|--|---|
| | | | RANGE FROM | TO | MEDIUM VALUE | HYDRAULIC CONDUCTIVITY (m/s) | COEFFICIENT OF CONSOLIDATION (c _v) (m ² /yr) |
| Upper Siltstone-Claystone | (Tcu) | 13 | 1x10 ⁻¹² | 3x10 ⁻⁸ | 1x10 ⁻¹⁰ | 1x10 ⁻¹⁰ (W76-1) 4x10 ⁻¹¹ (W77-4) | < 10 (W77-4) 400* (W77-3) |
| A zone siltstone and coal | (Tcc) | 6 | 1x10 ⁻¹¹ | 3x10 ⁻¹⁰ | 4x10 ⁻¹¹ | 9x10 ⁻⁹ (W78-2) | - |
| B zone coal | (Tcc) | 3 | 2x10 ⁻⁷ | 5x10 ⁻⁷ | 4x10 ⁻⁷ | - | - |
| C zone siltstone and coal | (Tcc) | 13 | 3x10 ⁻¹¹ | 3x10 ⁻⁸ | 1.4x10 ⁻¹⁰ | - | - |
| D zone coal | (Tcc) | 12 | 6x10 ⁻⁹ | 1x10 ⁻⁶ | 5x10 ⁻⁷ | 6x10 ⁻¹¹ (W77-1) | < 45 (W77-1) |
| Lower Siltstone-Sandstone-Conglomerate | (Tcl) | 15 | 2x10 ⁻¹¹ | 5x10 ⁻⁹ | 8x10 ⁻¹¹ | 5x10 ⁻¹² (W77-2) | 500* (W77-2) |
| Conglomerate | (Tco1) | 4 | 9.5x10 ⁻¹¹ | 2.9x10 ⁻⁹ | 1.3x10 ⁻¹⁰ | - | - |
| Limestone | | 7 | 1.2x10 ⁻⁹ | 1x10 ⁻⁴ | 3x10 ⁻⁸ | - | - |
| Basalt | | 5 | 2.3x10 ⁻¹¹ | 1.8x10 ⁻⁴ | 7x10 ⁻⁹ | - | - |
| Greenstone | | 5 | 4x10 ⁻¹⁰ | 5x10 ⁻⁷ | 1.8x10 ⁻⁷ | - | - |

• These values were calculated using some assumptions and may be rather high.

TABLE 5-4

INCREMENTAL DESIGN PIT QUANTITIES

** 2M SELECTIVITY -- PIT X2P/LAM **

SUMMARY OF MINING INCREMENTS

| --PIT-NAME---- | CUMULATIVE | | | INCREMENT | | | |
|----------------|------------|-------|------|-----------|-------|------|--------|
| | ORE TONS | HHV | S.R. | ORE TONS | HHV | S.R. | CUTOFF |
| R2PL1.DAT | 1537. | 18.45 | 2.16 | 1537. | 18.45 | 2.16 | 9.30 |
| R2PA2.DAT | 4672. | 18.99 | 1.43 | 3135. | 19.25 | 1.07 | 9.30 |
| R2PA3.DAT | 9990. | 18.79 | 1.27 | 5318. | 18.62 | 1.12 | 9.30 |
| R2PA4.DAT | 18210. | 18.63 | 1.29 | 8220. | 18.44 | 1.32 | 9.30 |
| R2PA5.DAT | 29772. | 18.62 | 1.33 | 11562. | 18.60 | 1.40 | 9.30 |
| R2PL6.DAT | 43545. | 18.53 | 1.30 | 13773. | 18.35 | 1.22 | 9.30 |
| R2PL7.DAT | 58407. | 18.46 | 1.27 | 14862. | 18.24 | 1.17 | 9.30 |
| R2PL8.DAT | 73116. | 18.30 | 1.28 | 14709. | 17.67 | 1.32 | 9.30 |
| R2PL9.DAT | 84175. | 18.23 | 1.30 | 11059. | 17.74 | 1.42 | 9.30 |
| R2PL0.DAT | 95624. | 18.15 | 1.23 | 11449. | 17.59 | 0.75 | 9.30 |
| R2PM1.DAT | 109441. | 18.13 | 1.19 | 13817. | 17.98 | 0.93 | 9.30 |
| R2PM2.DAT | 163209. | 17.91 | 1.23 | 53768. | 17.45 | 1.29 | 9.30 |
| R2PM3.DAT | 213231. | 17.99 | 1.12 | 50022. | 18.26 | 0.78 | 9.30 |
| R2PM4.DAT | 254804. | 18.01 | 1.14 | 41573. | 18.12 | 1.21 | 9.30 |
| R2PM5.DAT | 307069. | 17.97 | 1.18 | 52265. | 17.78 | 1.38 | 9.30 |
| R2PM6.DAT | 335646. | 18.09 | 1.25 | 28577. | 19.30 | 1.99 | 9.30 |

TABLE 5-5

ADJUSTED PRODUCTION SCHEDULE

1 ** 2M SELECTIVITY -- PIT X2PL/M ** PRODUCTION BASED ON TONS * HHV **

| YEAR | YEARLY SCHEDULE | | | | CUMULATIVE SCHEDULE | | | |
|------|-----------------|--------|--------|---------|---------------------|--------|---------|---------|
| | MILL FEED | GRADE | WASTE | S.R. | MILL FEED | GRADE | WASTE | S.R. |
| 1 | 0. | 0.000 | 0. | 0.000 * | 0. | 0.000 | 0. | 0.000 * |
| 2 | 1139. | 17.597 | 3697. | 3.246 * | 1139. | 17.597 | 3697. | 3.246 * |
| 3 | 2950. | 19.292 | 4375. | 1.483 * | 4089. | 18.820 | 8073. | 1.974 * |
| 4 | 4759. | 18.155 | 7474. | 1.570 * | 8848. | 18.462 | 15546. | 1.757 * |
| 5 | 7371. | 17.994 | 10720. | 1.454 * | 16220. | 18.249 | 26266. | 1.619 * |
| 6 | 9249. | 18.455 | 13678. | 1.479 * | 25469. | 18.324 | 39944. | 1.568 * |
| 7 | 10684. | 17.914 | 16082. | 1.505 * | 36153. | 18.203 | 56026. | 1.550 * |
| 8 | 10452. | 18.762 | 14973. | 1.433 * | 46605. | 18.328 | 70999. | 1.523 * |
| 9 | 10458. | 18.750 | 15301. | 1.463 * | 57063. | 18.406 | 86300. | 1.512 * |
| 10 | 11555. | 16.970 | 16827. | 1.456 * | 68618. | 18.164 | 103127. | 1.503 * |
| 11 | 10842. | 18.087 | 18016. | 1.662 * | 79460. | 18.153 | 121142. | 1.525 * |
| 12 | 11172. | 17.553 | 14752. | 1.320 * | 90631. | 18.079 | 135894. | 1.499 * |
| 13 | 11535. | 17.000 | 20503. | 1.777 * | 102166. | 17.957 | 156397. | 1.531 * |
| 14 | 10602. | 18.496 | 17171. | 1.620 * | 112768. | 18.008 | 173568. | 1.539 * |
| 15 | 11517. | 17.026 | 18848. | 1.637 * | 124286. | 17.917 | 192416. | 1.548 * |
| 16 | 11387. | 17.221 | 6312. | 0.554 * | 135673. | 17.859 | 198728. | 1.465 * |
| 17 | 11081. | 17.696 | 15212. | 1.373 * | 146753. | 17.846 | 213940. | 1.458 * |
| 18 | 10047. | 18.126 | 10371. | 1.032 * | 156800. | 17.864 | 224311. | 1.431 * |
| 19 | 10215. | 17.827 | 14222. | 1.392 * | 167015. | 17.862 | 238532. | 1.428 * |
| 20 | 10557. | 17.250 | 14166. | 1.342 * | 177572. | 17.826 | 252699. | 1.423 * |
| 21 | 10212. | 17.833 | 9839. | 0.964 * | 187784. | 17.826 | 262538. | 1.398 * |
| 22 | 9961. | 18.283 | 10559. | 1.060 * | 197745. | 17.849 | 273097. | 1.381 * |
| 23 | 9813. | 18.557 | 12892. | 1.314 * | 207558. | 17.883 | 285988. | 1.378 * |
| 24 | 9841. | 18.506 | 16344. | 1.661 * | 217399. | 17.911 | 302332. | 1.391 * |
| 25 | 9914. | 18.368 | 12140. | 1.224 * | 227313. | 17.931 | 314472. | 1.383 * |
| 26 | 10184. | 17.883 | 9859. | 0.968 * | 237496. | 17.929 | 324331. | 1.366 * |
| 27 | 10068. | 18.089 | 9240. | 0.918 * | 247564. | 17.935 | 333571. | 1.347 * |
| 28 | 8284. | 18.591 | 7335. | 0.886 * | 255848. | 17.956 | 340907. | 1.332 * |
| 29 | 8478. | 18.164 | 14509. | 1.711 * | 264326. | 17.963 | 355416. | 1.345 * |
| 30 | 8395. | 18.345 | 8059. | 0.960 * | 272721. | 17.975 | 363475. | 1.333 * |
| 31 | 8561. | 17.988 | 11103. | 1.297 * | 281283. | 17.975 | 374577. | 1.332 * |
| 32 | 8584. | 17.941 | 12145. | 1.415 * | 289867. | 17.974 | 386722. | 1.334 * |
| 33 | 8653. | 17.797 | 6972. | 0.806 * | 298520. | 17.969 | 393694. | 1.319 * |
| 34 | 8508. | 18.101 | 10222. | 1.201 * | 307028. | 17.973 | 403915. | 1.316 * |
| 35 | 8247. | 18.675 | 9846. | 1.194 * | 315275. | 17.991 | 413761. | 1.312 * |
| 36 | 8053. | 19.123 | 1871. | 0.232 * | 323328. | 18.019 | 415632. | 1.285 * |
| 37 | 7622. | 20.205 | 1960. | 0.257 * | 330950. | 18.070 | 417592. | 1.262 * |

YEAR 1 IS PREPRODUCTION AND IS NOT INC. IN CUMULATIVE

| MATERIALS MINED Quantities in (10 ⁶) | PRE-PRODUCTION YEARS | | | | PRODUCTION YEARS | | | | | | | | | | | | | | | | | | | | | | | | | | | | | | | TOTAL | | | | | | |
|---|----------------------|----|----|------|------------------|-------|--------|--------|--------|--------|--------|--------|--------|---------|---------|---------|---------|---------|---------|---------|---------|---------|---------|---------|---------|---------|---------|---------|---------|---------|---------|---------|---------|---------|---------|---------|---------|---------|---------|---------|---------|--------|
| | -4 | -3 | -2 | -1 | 1 | 2 | 3 | 4 | 5 | 6 | 7 | 8 | 9 | 10 | 11 | 12 | 13 | 14 | 15 | 16 | 17 | 18 | 19 | 20 | 21 | 22 | 23 | 24 | 25 | 26 | 27 | 28 | 29 | 30 | 31 | | 32 | 33 | 34 | 35 | | |
| COAL MINED (Tonnes) | Annual | | | 0 | 1.14 | 2.95 | 4.76 | 7.35 | 9.23 | 10.46 | 10.60 | 10.52 | 11.49 | 10.69 | 11.37 | 11.17 | 10.86 | 11.64 | 11.40 | 11.12 | 10.06 | 10.06 | 10.67 | 10.15 | 9.90 | 9.66 | 9.57 | 10.40 | 10.03 | 9.83 | 8.01 | 9.19 | 8.39 | 8.55 | 8.58 | 8.64 | 8.61 | 8.25 | 8.05 | 7.62 | | |
| | Cumul. | | | 0 | 1.14 | 4.09 | 8.85 | 16.20 | 25.43 | 35.88 | 46.48 | 56.99 | 68.49 | 79.18 | 90.55 | 101.71 | 112.57 | 124.21 | 135.61 | 146.73 | 156.79 | 166.85 | 177.52 | 187.67 | 197.56 | 207.22 | 216.79 | 227.19 | 237.21 | 247.05 | 255.05 | 264.24 | 272.63 | 281.18 | 289.77 | 298.41 | 307.02 | 315.28 | 323.33 | 330.95 | 330.95 | |
| MJ/Kg (Dry Basis) | Annual | | | 0 | 17.6 | 19.3 | 18.2 | 18.1 | 18.5 | 18.3 | 18.5 | 18.6 | 17.1 | 18.3 | 17.3 | 17.6 | 18.1 | 17.0 | 17.2 | 17.6 | 18.0 | 18.1 | 17.1 | 17.9 | 18.4 | 18.9 | 19.0 | 17.5 | 18.2 | 18.5 | 19.2 | 17.0 | 18.4 | 18.0 | 17.9 | 17.8 | 17.9 | 18.7 | 19.1 | 20.2 | | |
| | Cumul. | | | 0 | 17.6 | 18.8 | 18.5 | 18.3 | 18.4 | 18.3 | 18.4 | 18.4 | 18.2 | 18.2 | 18.1 | 18.0 | 18.0 | 17.9 | 17.9 | 17.8 | 17.9 | 17.9 | 18.0 | 17.9 | 18.0 | 17.9 | 18.0 | 18.0 | 18.0 | 18.0 | 18.0 | 18.0 | 18.0 | 18.0 | 18.0 | 18.0 | 18.0 | 18.0 | 18.0 | 18.0 | 18.0 | |
| ASH CONTENT (%, Dry Basis) | Annual | | | | 33.52 | 33.52 | 33.52 | 33.52 | 33.52 | 32.80 | 32.80 | 32.80 | 32.80 | 32.80 | 32.80 | 35.31 | 35.31 | 35.31 | 35.31 | 35.31 | 33.90 | 33.90 | 33.90 | 33.90 | 33.90 | 32.77 | 32.77 | 32.77 | 32.77 | 32.77 | 32.40 | 32.40 | 32.40 | 32.40 | 32.40 | 32.40 | 32.40 | 32.40 | 32.40 | 32.40 | 32.40 | 33.47 |
| SULPHUR CONTENT (%, Dry Basis) | Annual | | | | 0.55 | 0.52 | 0.55 | 0.56 | 0.53 | 0.56 | 0.53 | 0.53 | 0.53 | 0.53 | 0.53 | 0.54 | 0.54 | 0.54 | 0.54 | 0.54 | 0.50 | 0.50 | 0.50 | 0.50 | 0.50 | 0.48 | 0.48 | 0.48 | 0.48 | 0.48 | 0.48 | 0.48 | 0.48 | 0.48 | 0.48 | 0.48 | 0.48 | 0.48 | 0.48 | 0.48 | 0.48 | 0.51 |
| HEAT UNITS DELIVERED IN MJ x 10 ⁹ (Based on 23.5% Moisture and Coal Cut-Off at 9.3 MJ/Kg) | Annual | | | | 15.35 | 43.56 | 66.27 | 101.77 | 130.63 | 146.43 | 150.01 | 149.69 | 150.31 | 149.65 | 150.48 | 150.39 | 150.37 | 149.60 | 150.00 | 149.72 | 138.53 | 139.30 | 139.58 | 138.99 | 139.35 | 139.67 | 139.10 | 139.23 | 139.65 | 139.12 | 117.65 | 118.11 | 118.10 | 117.73 | 117.49 | 117.65 | 117.90 | 118.02 | 117.62 | 117.75 | | |
| | Cumul. | | | | 15.35 | 58.91 | 125.18 | 226.95 | 257.58 | 504.01 | 654.03 | 803.72 | 954.03 | 1103.68 | 1254.16 | 1404.55 | 1554.92 | 1704.52 | 1854.52 | 2004.24 | 2142.77 | 2282.07 | 2421.65 | 2560.64 | 2699.99 | 2839.66 | 2978.76 | 3117.99 | 3257.64 | 3396.76 | 3514.41 | 3632.52 | 3750.62 | 3868.35 | 3985.84 | 4103.49 | 4221.39 | 4339.41 | 4457.03 | 4574.78 | 4574.78 | |
| COAL Fuel above cut-off of 9.3 mj/kg (bank cubic metres) | Annual | | | | 0.76 | 1.97 | 3.19 | 4.93 | 6.19 | 7.02 | 7.11 | 7.06 | 7.71 | 7.17 | 7.63 | 7.49 | 7.28 | 7.81 | 7.65 | 7.46 | 6.75 | 6.75 | 7.16 | 6.81 | 6.64 | 6.48 | 6.42 | 6.98 | 6.73 | 6.60 | 5.38 | 6.17 | 5.63 | 5.74 | 5.76 | 5.80 | 5.78 | 5.54 | 5.40 | 5.11 | | |
| | Cumul. | | | | 0.76 | 2.74 | 5.93 | 10.87 | 17.06 | 24.08 | 31.19 | 38.24 | 45.95 | 53.14 | 60.77 | 68.26 | 75.55 | 83.36 | 91.01 | 98.47 | 105.23 | 111.98 | 119.14 | 125.95 | 132.59 | 139.07 | 145.50 | 152.48 | 159.20 | 165.81 | 171.17 | 177.30 | 182.97 | 188.71 | 194.48 | 200.28 | 206.05 | 211.60 | 217.00 | 222.11 | 222.11 | |
| WASTE Above Bedrock | Annual | | | 2.25 | 2.78 | 3.29 | 5.60 | 8.04 | 11.72 | 12.43 | 10.43 | 10.50 | 10.63 | 11.16 | 11.18 | 11.13 | 10.75 | 10.62 | 9.84 | 9.09 | 8.80 | 8.07 | 7.35 | 6.70 | 6.57 | 2.16 | 2.16 | 2.10 | 2.10 | 2.10 | 6.00 | 6.01 | 6.00 | 6.01 | 6.01 | 6.01 | 6.01 | 5.99 | 1.43 | 1.20 | 250.22 | |
| | Cumul. | | | 2.25 | 5.03 | 8.32 | 13.92 | 21.96 | 33.68 | 46.11 | 56.54 | 67.07 | 77.60 | 88.23 | 99.41 | 110.59 | 121.77 | 132.95 | 144.13 | 155.31 | 166.49 | 177.67 | 188.85 | 200.03 | 211.21 | 222.39 | 233.57 | 244.75 | 255.93 | 267.11 | 278.29 | 289.47 | 300.65 | 311.83 | 323.01 | 334.19 | 345.37 | 356.55 | 367.73 | 378.91 | 390.09 | 401.27 |
| WASTE Bedrock | Annual | | | 0.75 | 0.92 | 1.09 | 1.87 | 2.68 | 3.90 | 4.14 | 6.39 | 6.44 | 6.51 | 6.84 | 6.85 | 7.12 | 6.87 | 6.79 | 6.29 | 5.81 | 5.40 | 4.95 | 4.50 | 4.10 | 4.02 | 8.12 | 8.12 | 7.89 | 7.92 | 7.90 | 3.83 | 3.84 | 3.84 | 3.84 | 3.84 | 3.85 | 3.85 | 3.84 | 3.83 | 0.92 | 0.76 | 176.58 |
| | Cumul. | | | 0.75 | 1.67 | 2.76 | 4.63 | 7.31 | 11.21 | 15.35 | 21.74 | 28.18 | 34.69 | 41.53 | 48.38 | 55.23 | 62.08 | 68.93 | 75.78 | 82.63 | 89.48 | 96.33 | 103.18 | 110.03 | 116.88 | 123.73 | 130.58 | 137.43 | 144.28 | 151.13 | 157.98 | 164.83 | 171.68 | 178.53 | 185.38 | 192.23 | 199.08 | 205.93 | 212.78 | 219.63 | 226.48 | 233.33 |
| SUB - TOTAL WASTE (bank cubic metres) | Annual | | | 3.00 | 3.70 | 4.38 | 7.47 | 10.72 | 15.62 | 16.57 | 16.82 | 16.94 | 17.14 | 18.00 | 18.03 | 18.25 | 17.62 | 17.41 | 16.13 | 14.90 | 14.20 | 13.02 | 11.85 | 10.80 | 10.59 | 10.28 | 10.28 | 9.99 | 10.02 | 10.00 | 9.83 | 9.85 | 9.84 | 9.85 | 9.86 | 9.86 | 9.85 | 9.82 | 2.35 | 1.96 | | |
| | Cumul. | | | 3.00 | 6.70 | 11.08 | 18.55 | 29.27 | 44.89 | 61.46 | 78.28 | 95.22 | 112.36 | 130.36 | 148.39 | 166.64 | 184.26 | 201.67 | 217.80 | 232.70 | 246.90 | 259.92 | 271.77 | 282.57 | 293.16 | 303.44 | 313.72 | 323.71 | 333.73 | 343.73 | 353.56 | 363.41 | 373.25 | 383.10 | 392.96 | 402.82 | 412.67 | 422.49 | 424.84 | 426.80 | 426.80 | |
| TOTAL MATERIAL MINED (bank cubic metres) | Annual | | | 4.46 | 6.35 | 10.66 | 15.65 | 21.81 | 23.59 | 23.93 | 24.00 | 24.85 | 25.17 | 25.66 | 25.74 | 24.90 | 25.22 | 23.78 | 22.36 | 20.95 | 19.77 | 19.01 | 17.61 | 17.23 | 16.76 | 16.70 | 16.97 | 16.75 | 16.60 | 15.21 | 16.02 | 15.47 | 9.58 | 15.62 | 15.66 | 15.63 | 15.81 | 7.75 | 7.07 | | | |
| | Cumul. | | | 4.46 | 10.81 | 21.47 | 37.12 | 58.93 | 82.52 | 106.51 | 130.51 | 154.51 | 179.51 | 204.51 | 229.51 | 254.51 | 279.51 | 304.51 | 329.51 | 354.51 | 379.51 | 404.51 | 429.51 | 454.51 | 479.51 | 504.51 | 529.51 | 554.51 | 579.51 | 604.51 | 629.51 | 654.51 | 679.51 | 704.51 | 729.51 | 754.51 | 779.51 | 804.51 | 829.51 | 854.51 | 879.51 | |
| STRIP RATIO bank cubic metres waste tonnes of coal mined | Annual | | | 3.25 | 1.48 | 1.57 | 1.46 | 1.69 | 1.58 | 1.59 | 1.61 | 1.49 | 1.68 | 1.59 | 1.63 | 1.62 | 1.50 | 1.41 | 1.34 | 1.41 | 1.29 | 1.11 | 1.06 | 1.07 | 1.06 | 1.07 | 0.96 | 1.00 | 1.02 | 1.23 | 1.07 | 1.17 | 1.15 | 1.15 | 1.14 | 1.14 | 1.19 | 0.29 | 0.26 | | | |
| | Cumul. | | | 3.25 | 4.73 | 6.30 | 7.76 | 9.45 | 11.03 | 12.62 | 14.21 | 15.80 | 17.39 | 18.98 | 20.57 | 22.16 | 23.75 | 25.34 | 26.93 | 28.52 | 30.11 | 31.70 | 33.29 | 34.88 | 36.47 | 38.06 | 39.65 | 41.24 | 42.83 | 44.42 | 46.01 | 47.60 | 49.19 | 50.78 | 52.37 | 53.96 | 55.55 | 57.14 | 58.73 | 60.32 | 61.91 | 63.50 |

HAT CREEK PROJECT

Table No. 5-6

Schedule of Annual Production

TABLE 5-7

HOOTH MEADOWS WASTE DUMP
 (Capacity by Lift - million bank m³)
 Embankment Crest at 1,005 m Elevation

| Elevation | <u>Retained Waste</u> | | <u>Embankment</u> | | <u>Total</u> | | <u>Year</u> | | | |
|-----------|-----------------------|-------|-------------------|--------|---------------|-------|-------------|----------|----|------|
| | 35-m Lift | Cum. | 35-m Lift | Cum. | 35-m Lift. | Cum. | Start | Complete | | |
| floor- | 880 | 0.63 | 0.63 | 4.97 | 4.97 | 5.60 | 5.60 | -2 | 2 | |
| | 880- | 915 | 14.95 | 15.58 | 17.52 | 22.49 | 32.47 | 38.07 | 1 | 6 |
| | 915- | 950 | 35.67 | 51.25 | 14.20 | 36.69 | 49.87 | 87.94 | 2 | 9 |
| | 950- | 985 | 58.86 | 110.11 | 9.15 | 45.84 | 68.01 | 155.95 | 6 | 14 |
| | 985- | 1,020 | 83.15 | 193.26 | 5.29 | 51.13 | 88.44 | 244.39 | 9 | 22 |
| | 1,020- | 1,055 | 82.19 | 275.45 | 4.77 | 55.90 | 86.96 | 331.35 | 23 | (35) |
| | 1,055- | 1,090 | 62.35 | 337.80 | 4.34 | 60.24 | 66.69 | 398.04 | - | |
| | 1,090- | 1,125 | 30.90 | 368.70 | 2.72 | 62.96 | 33.62 | 431.66 | - | |
| | 1,125- | 1,160 | 7.70 | 375.40 | 0.67 | 63.63 | 7.37 | 439.03 | - | |

Note: Embankment quantities also include material for the three secondary embankments North of Houth Meadows.

Available capacity after Year 35 = 134.03 million bank m³

TABLE 5-8

MEDICINE CREEK WASTE DUMP

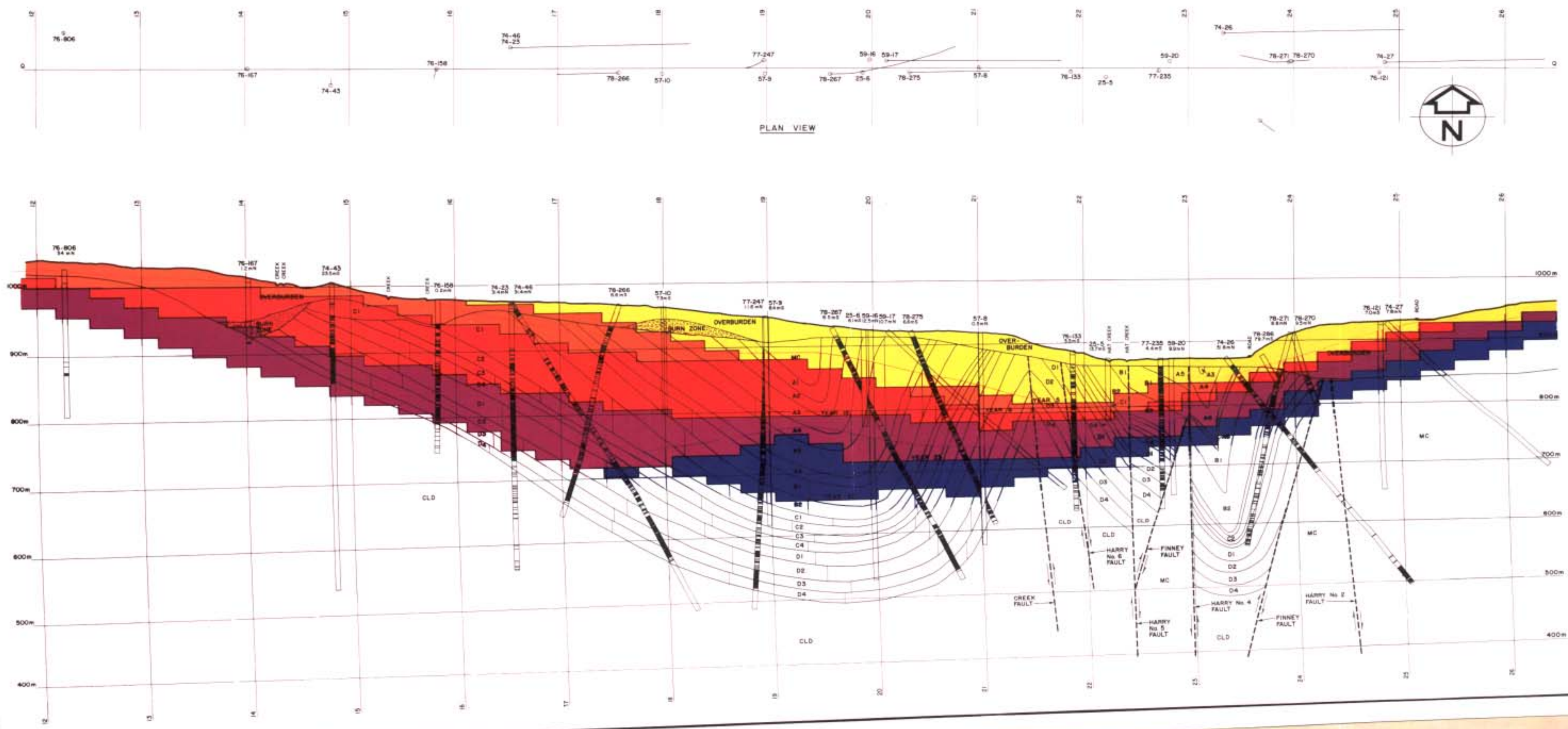
(Capacity by Lift - million bank m³)

Embankment Crest at 1,130 m Elevation

| Elevation | <u>Retained Waste</u> | | <u>Embankment</u> | | <u>Total</u> | | <u>Year</u> | |
|-------------|-----------------------|--------|-------------------|-------|--------------|--------|-------------|----------|
| | 35-m Lift | Cum. | 35-m Lift | Cum. | 35-m Lift | Cum. | Start | Complete |
| floor-1,040 | 2.11 | 2.11 | 7.26 | 7.26 | 9.37 | 9.37 | 12 | 14 |
| 1,040-1,075 | 11.46 | 13.57 | 10.16 | 17.42 | 21.62 | 72.74 | 15 | 18 |
| 1,075-1,110 | 29.75 | 43.32 | 15.04 | 32.46 | 44.79 | 117.53 | 18 | 26 |
| 1,110-1,145 | 40.85 | 84.17 | 9.29 | 41.75 | 50.14 | 167.67 | 26 | (35) |
| 1,145-1,170 | 16.16 | 100.33 | - | 4.75 | 16.16 | 183.83 | - | - |

Available capacity for mine waste after 35 years = 29 million bank m³

Potential capacity by raising embankment crest from 1,130 m to 1,200 m elevation = 310 million loose m³ for mine waste and ash.



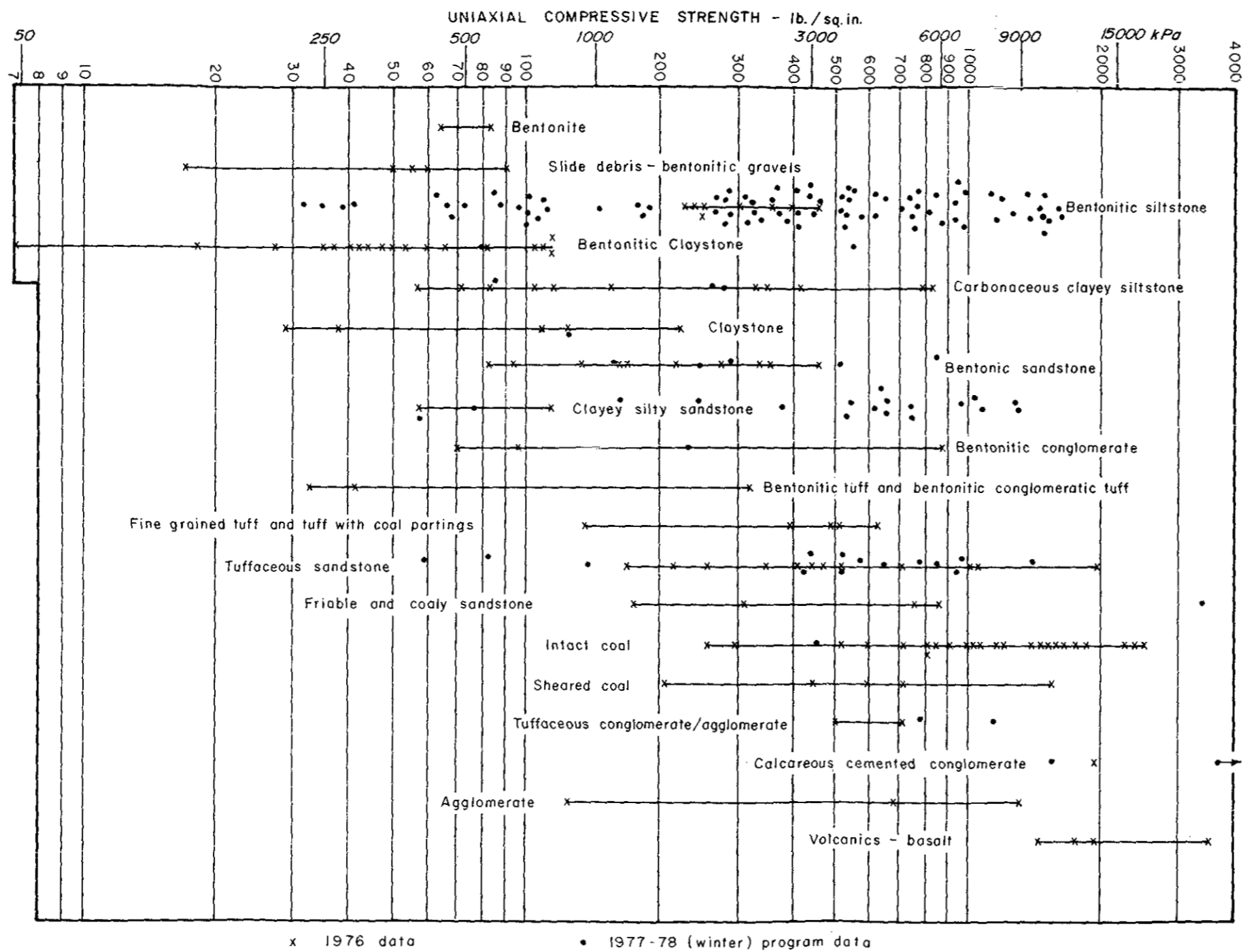
LEGEND

- First Increment to Year 5
- Year 5 to Year 8
- Year 8 to Year 15
- Year 15 to Year 25
- Year 25 to Year 35



HAT CREEK PROJECT
FIGURE 5-1
Interim Pit Development:
Cross Section Q

SOURCE: British Columbia Hydro and Power Authority



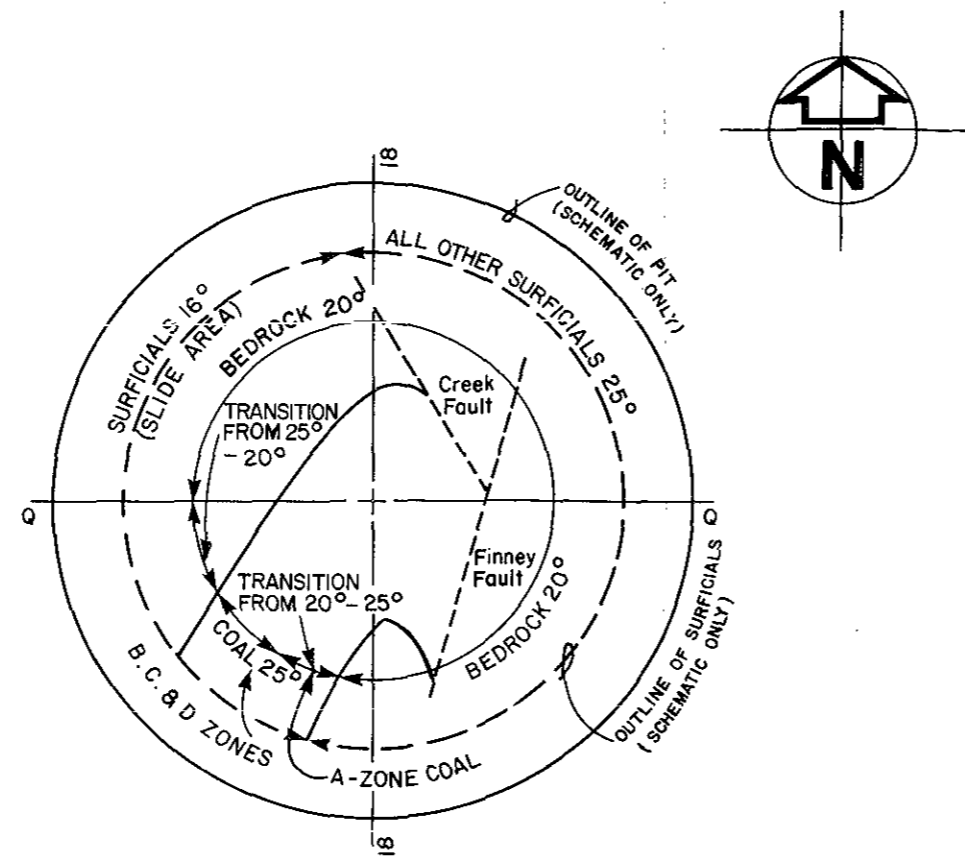
HAT CREEK PROJECT

FIGURE 5-2

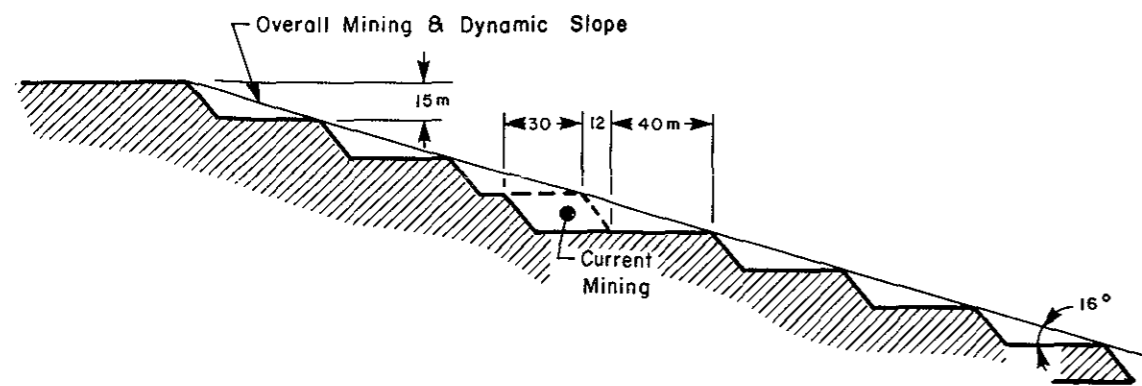
UNIAXIAL

COMPRESSIVE STRENGTHS

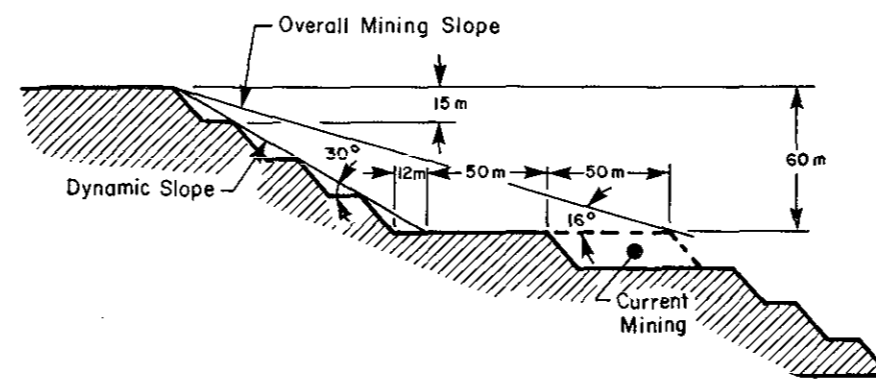
SOURCE: Golder Associates



35 YEAR PIT SLOPE ANGLES



(a) FOR MINING COAL



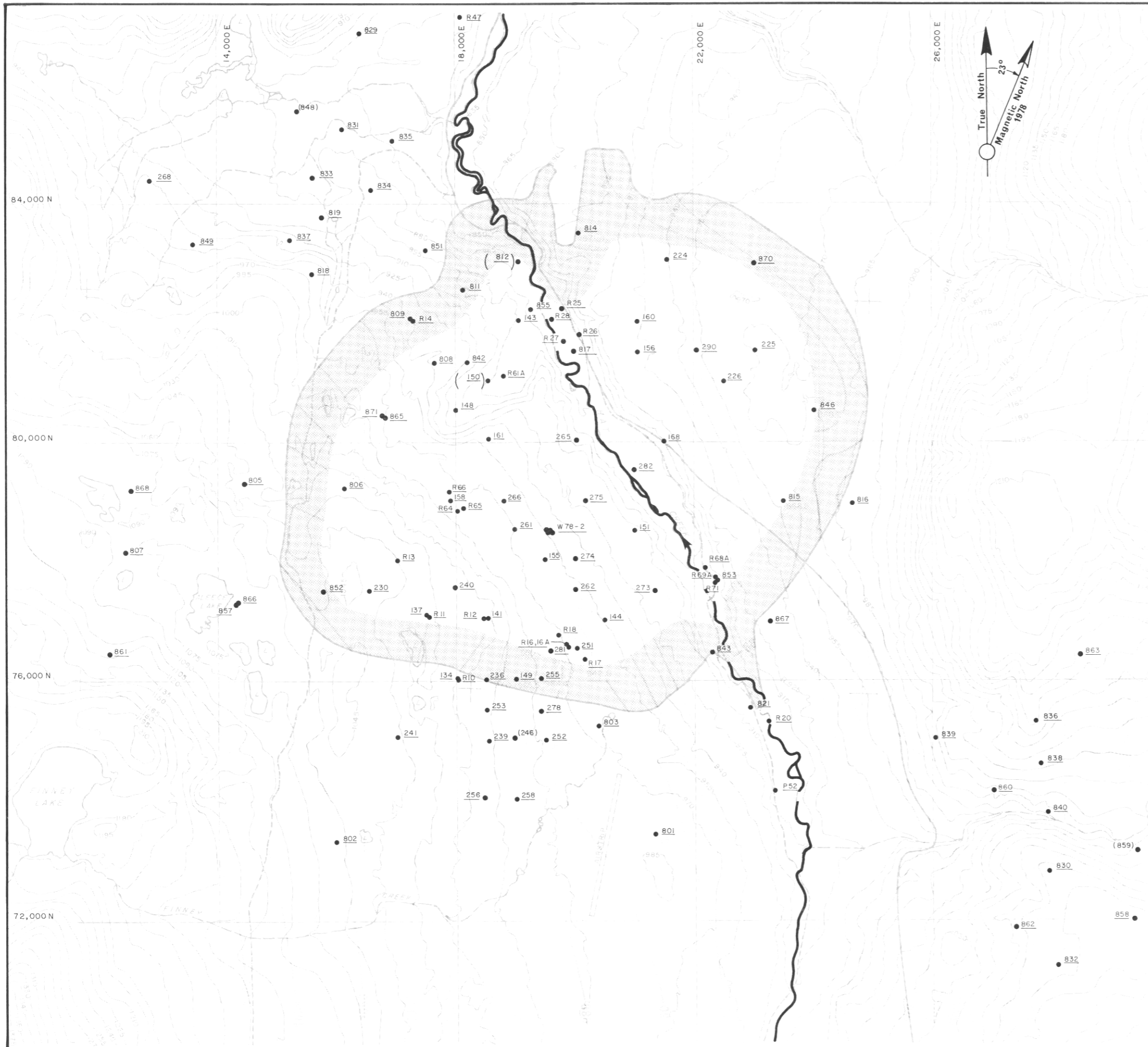
(b) FOR MINING WASTE AND OVERBURDEN

DYNAMIC SLOPE CROSS SECTION

HAT CREEK PROJECT

FIGURE 5-3
PIT SLOPES

SOURCE: Golder Associates



LEGEND

Piezometric contours, 20 metre intervals
elevations in metres

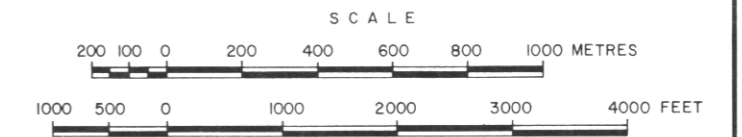
Inferred piezometric contours

● 829 Data point, upper (black) number = hole number
lower (blue) number = piezometric
elevation in metres

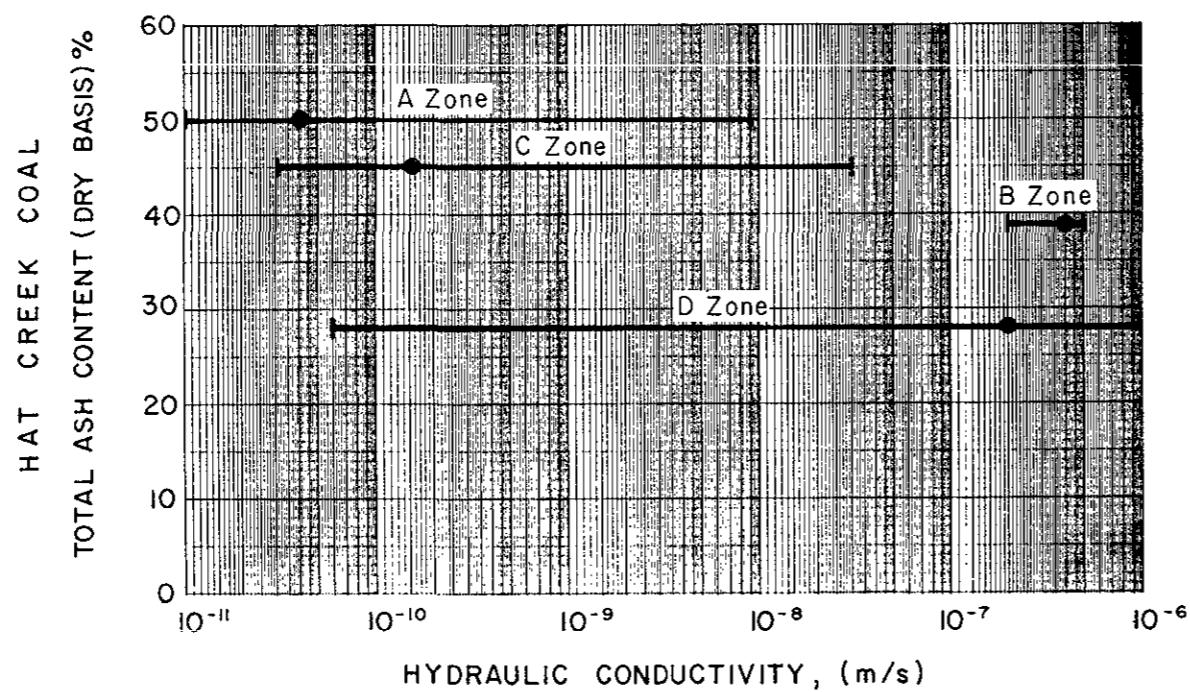
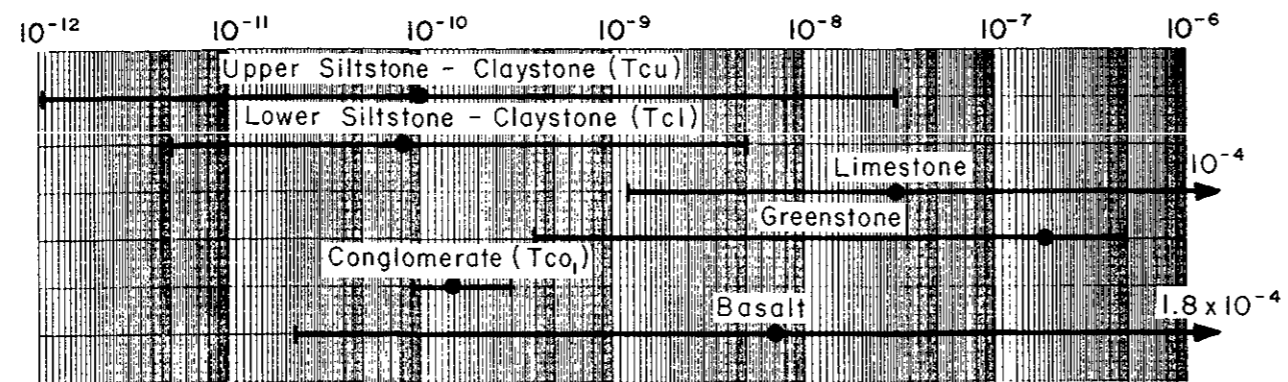
Bedrock groundwater discharge areas, other than
those along Hat Creek

NOTES

1. Due to the variation of piezometric elevations both with depth and time, the contoured piezometric surface illustrated in this drawing must be viewed as a generalized representation only.
2. Piezometric elevations are for October 1978.
3. Data points in brackets require the following explanatory notes:
 - Artesian pressures exist in drill holes DDH-77-848, DDH-77-246 and DDH-78-859. Although the piezometric elevations at these locations are not known at present, the artesian pressures have influenced the configuration of the piezometric contours.
 - The piezometer in drill hole DDH-76-812 has recently become inoperative. The represented piezometric elevation at this location has been estimated from the extrapolated piezometer hydrograph.
 - The piezometric elevation at drill hole DDH-76-150 is anomalously low and not fully contoured at present.

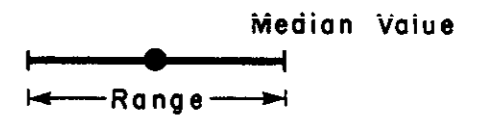


| | | |
|--|----------------|-----------------------------|
| Golder Associates | | |
| B.C. Hydro & Power Authority | | |
| HAT CREEK GEOTECHNICAL STUDY | | |
| GENERALIZED PIEZOMETRIC SURFACE CONTOURS OF BEDROCK MATERIALS | | |
| Drawn | S. H. | Checked <i>[Signature]</i> |
| Date | DEC. 1978 | Reviewed <i>[Signature]</i> |
| | Scale AS SHOWN | FIGURE 5-4 |



NOTE: Values are based on falling head test results shown in Appendix 12, Volume 6 and on pumping test data summarized in Table 6.

LEGEND

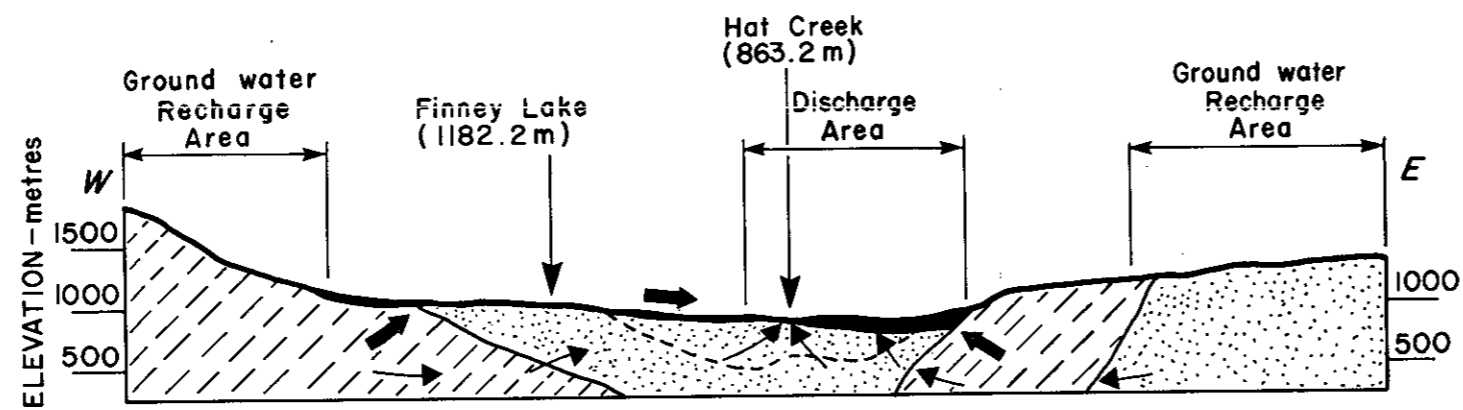


HAT CREEK PROJECT

FIGURE 5-5


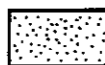





HYDRAULIC CONDUCTIVITY
VALUES DETERMINED IN-SITU

SOURCE: Golder Associates



NATURAL SCALE

LEGEND

-  Rocks with relatively high hydraulic conductivity (greater than 10^{-7} m/s)
-  Rocks with relatively low hydraulic conductivity (less than 10^{-7} m/s)
-  Surficial sediments
-  Low rate of groundwater flow
-  Higher rate of groundwater flow
-  (863.2m) Approx. elevation of water surface
-  Outline of proposed pit

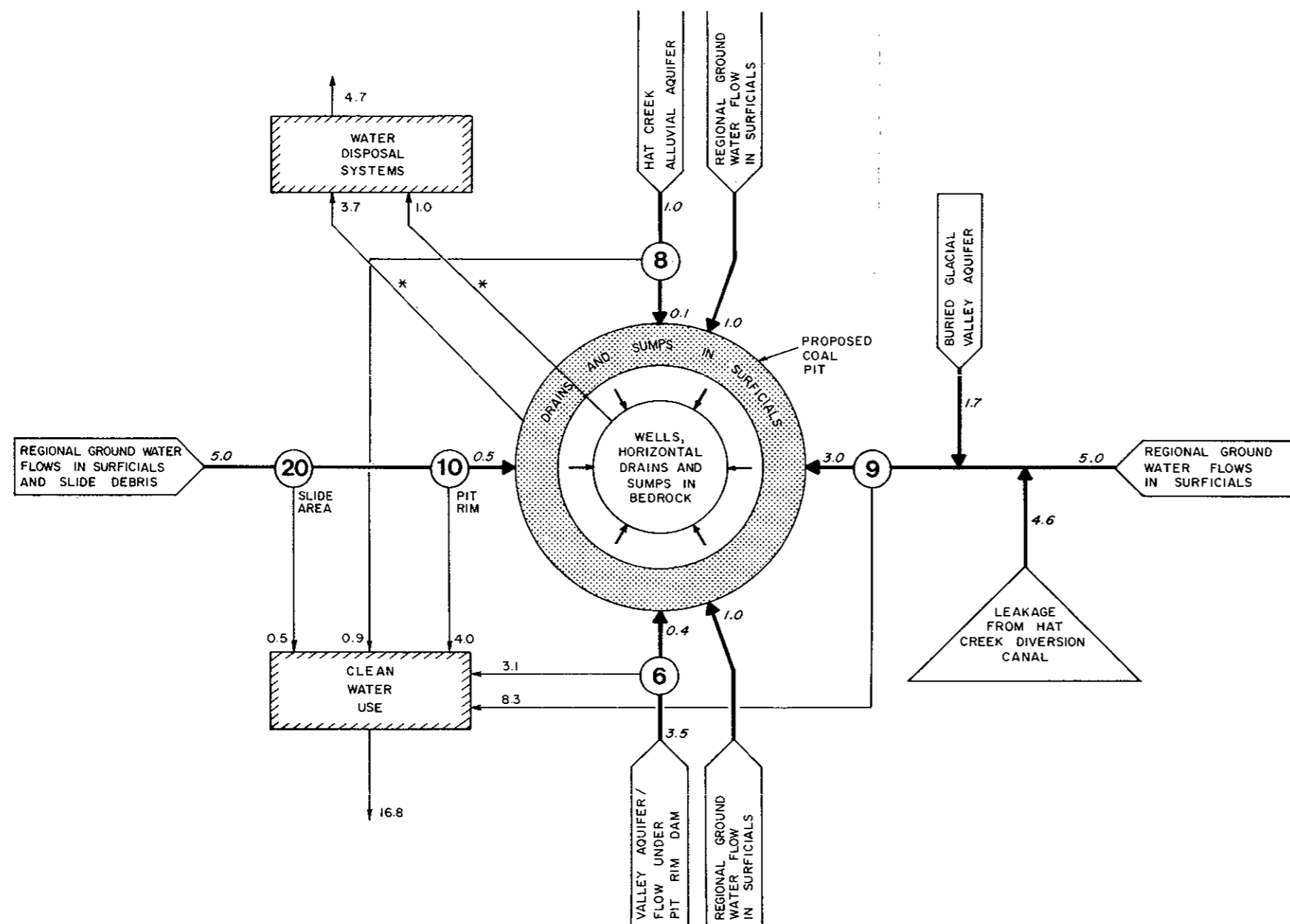
HAT CREEK PROJECT

FIGURE 5-6

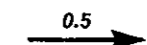

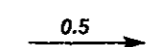
Hydrology


Section Through Hat Creek Valley

SOURCE: Golder Associates



LEGEND

- 
 Direction and magnitude of estimated average ground water flows ($10^{-3}m^3/s$)
- 
 Estimated number of pumped or bailed wells
- 
 Ground water either piped or conveyed by truck for treatment and/or disposal
- *

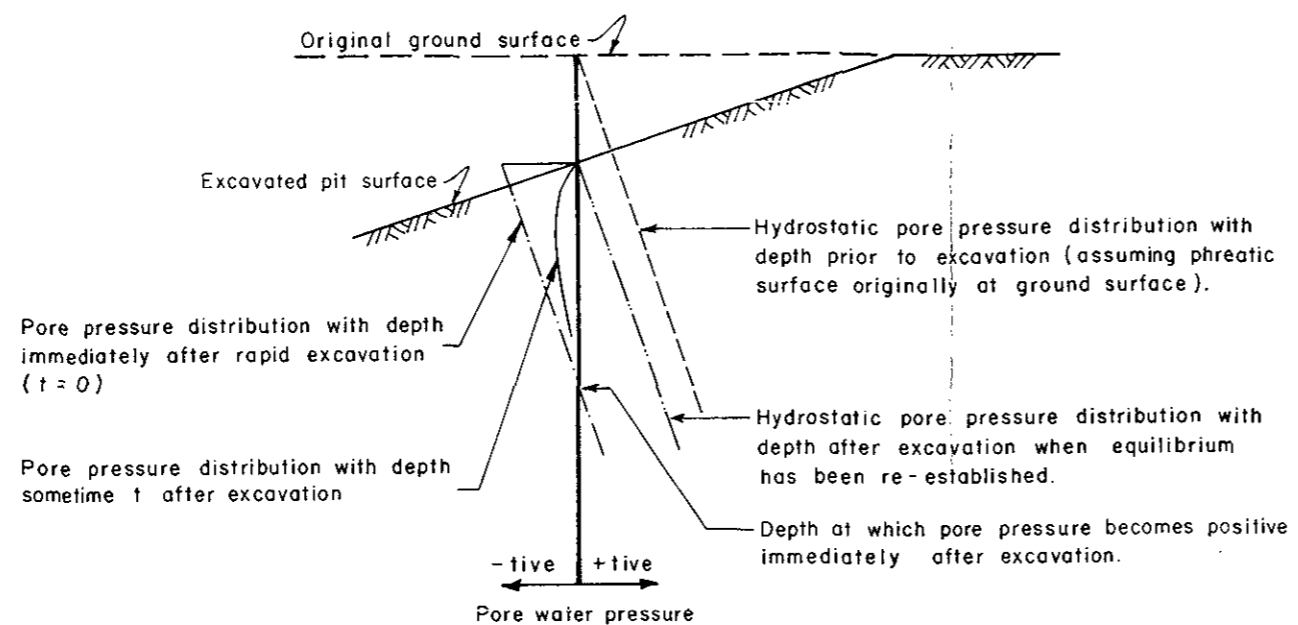
 These figures allow for water losses of up to 40% due to evaporation
- 
 Ground water flow collected from bedrock in base of pit ($1.7 \times 10^{-3}m^3/s$)

HAT CREEK PROJECT

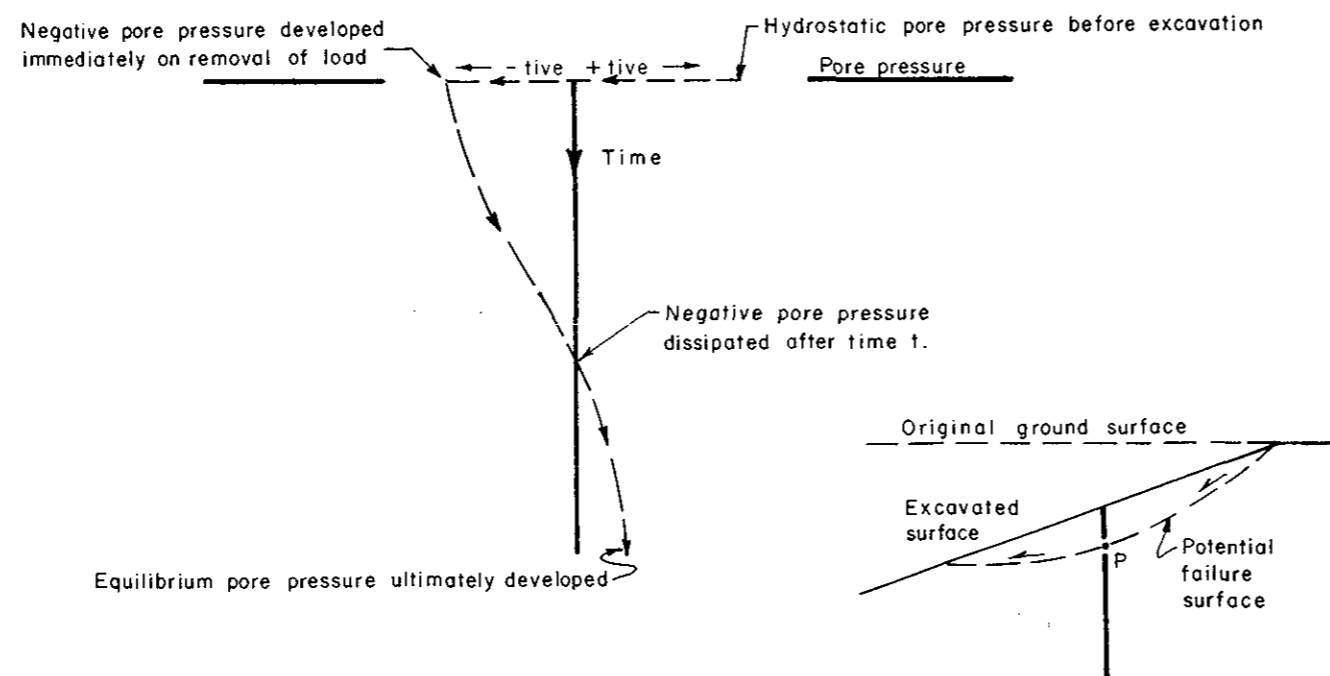
FIGURE 5-7
**MINE SEEPAGE AND
 DEWATERING FLOW CHART**

SOURCE: Golder Associates

a) PLOT OF DEPRESSURIZATION WITH DEPTH OF EXCAVATION



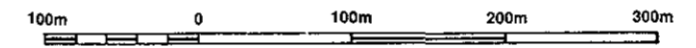
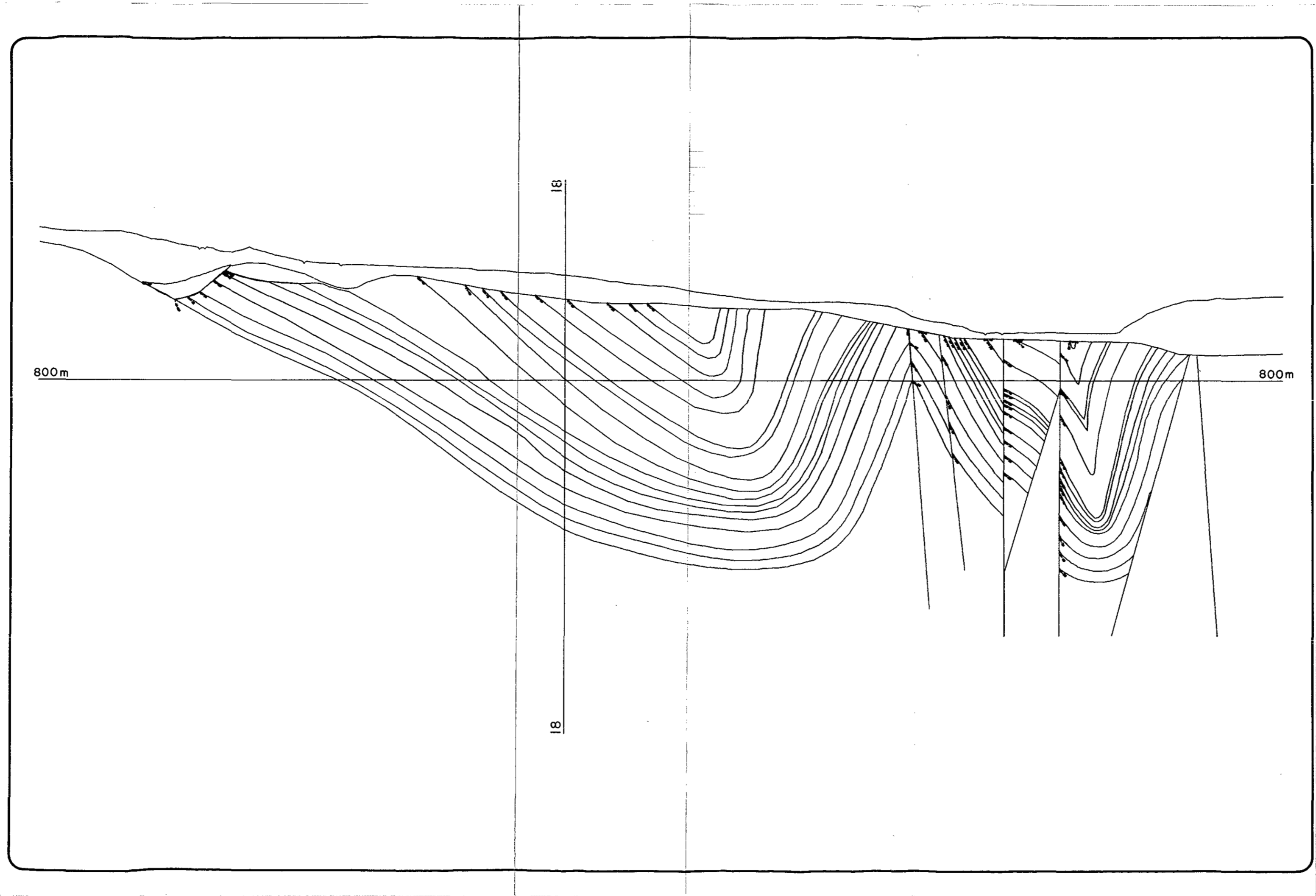
b) PLOT OF DEPRESSURIZATION WITH TIME FOR ANY POINT P ON A POTENTIAL FAILURE SURFACE.



HAT CREEK PROJECT

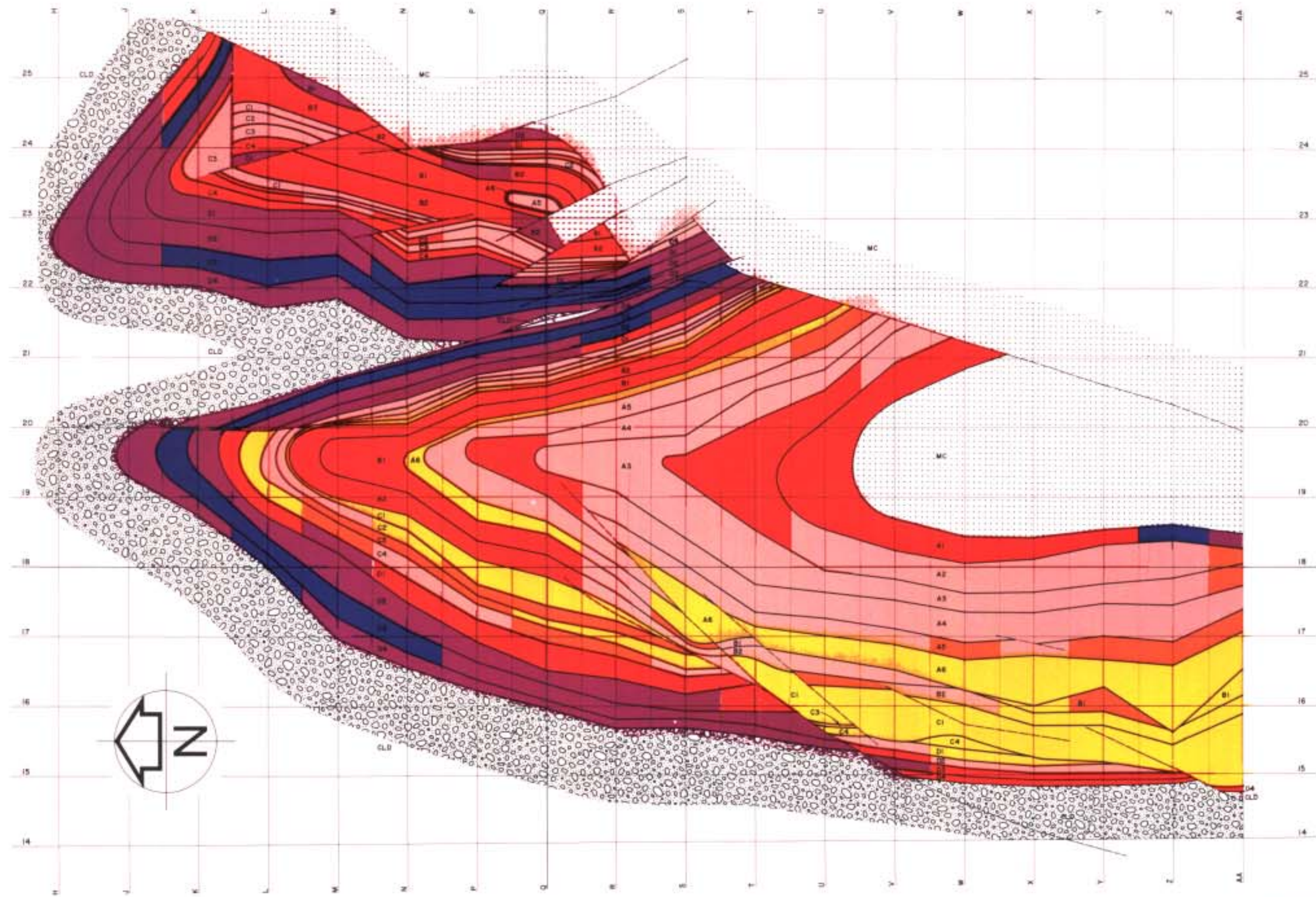
FIGURE 5-8
DEPRESSURIZATION
BY EXCAVATION

SOURCE: Golder Associates



HAT CREEK PROJECT
FIGURE 5-9
Typical VBM Cross-Section
Section Q
 SECTION DRAWN LOOKING NORTH

SOURCE: Mintec, Inc.



LEGEND

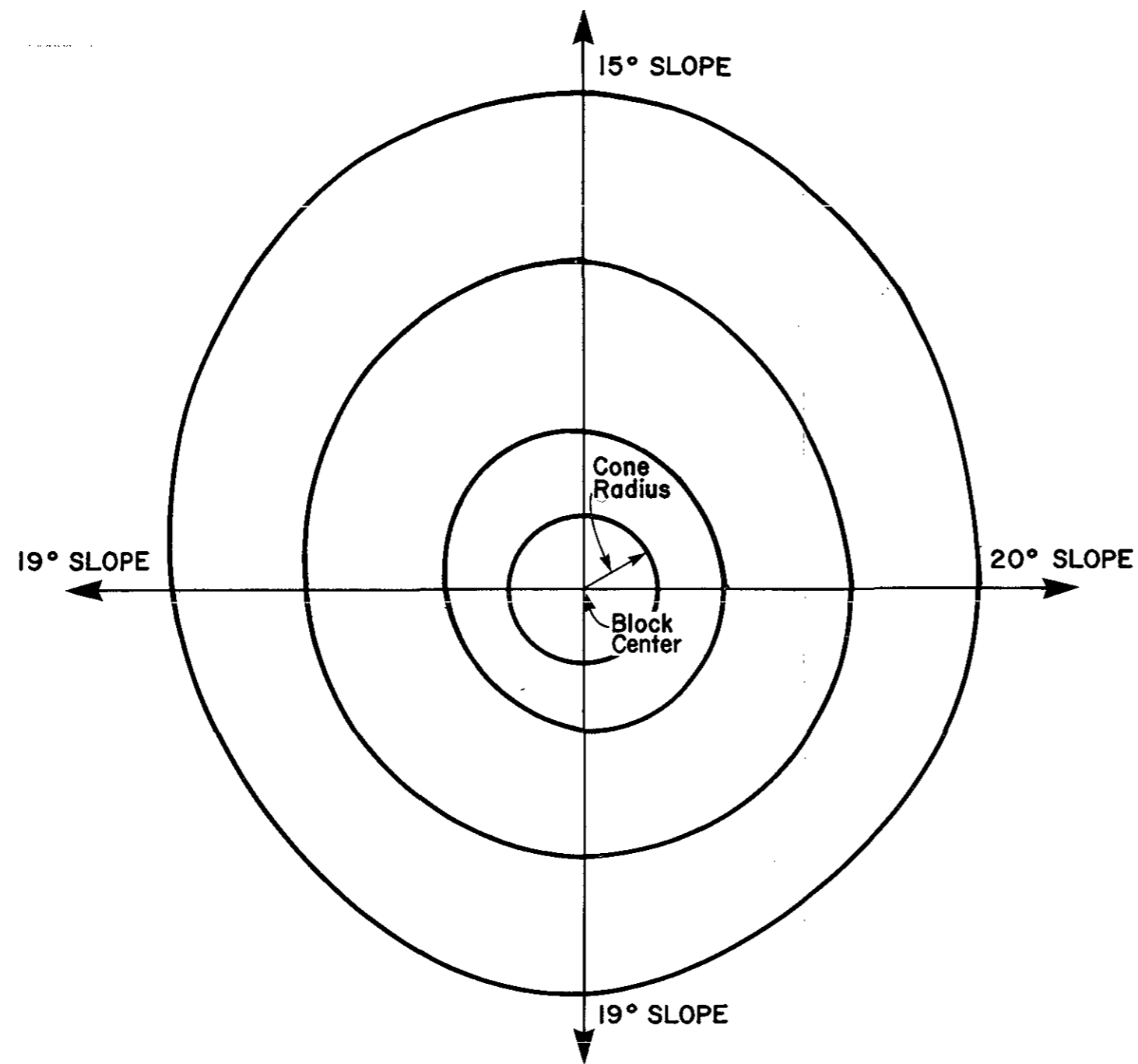
- SPECIFIC ENERGY RANGES
MJ/kg (DRY BASIS)**
- < 9.3
 - 9.3 - 13.0
 - 13.0 - 16.5
 - 16.5 - 20.0
 - 20.0 - 24.0
 - > 24.0
- MEDICINE CREEK FORMATION
 - COLDWATER FORMATION
 - A1 SUB-ZONE
 - FAULT
 - CONTACT



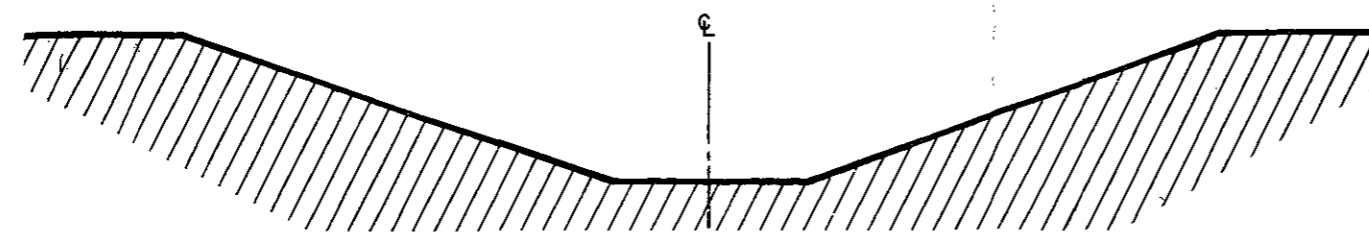
HAT CREEK PROJECT

**FIGURE 5-10
Bench Plan-Elevation 775**

SOURCE: Minner, Inc.



PLAN VIEW

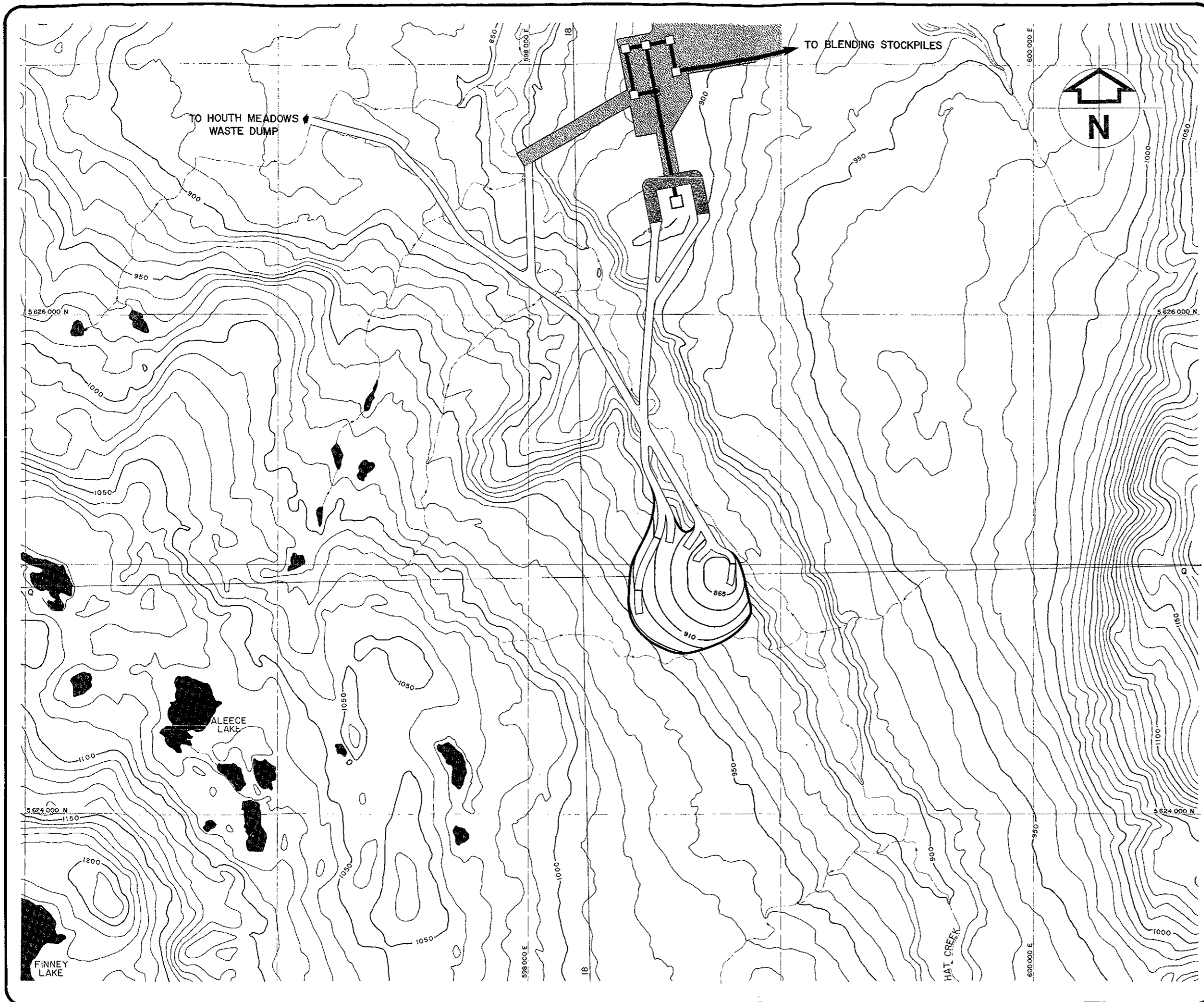


SECTION VIEW

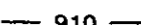

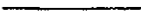




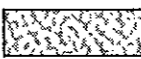
HAT CREEK PROJECT

FIGURE 5-11
Cone Geometry

SOURCE: Mintec, Inc.

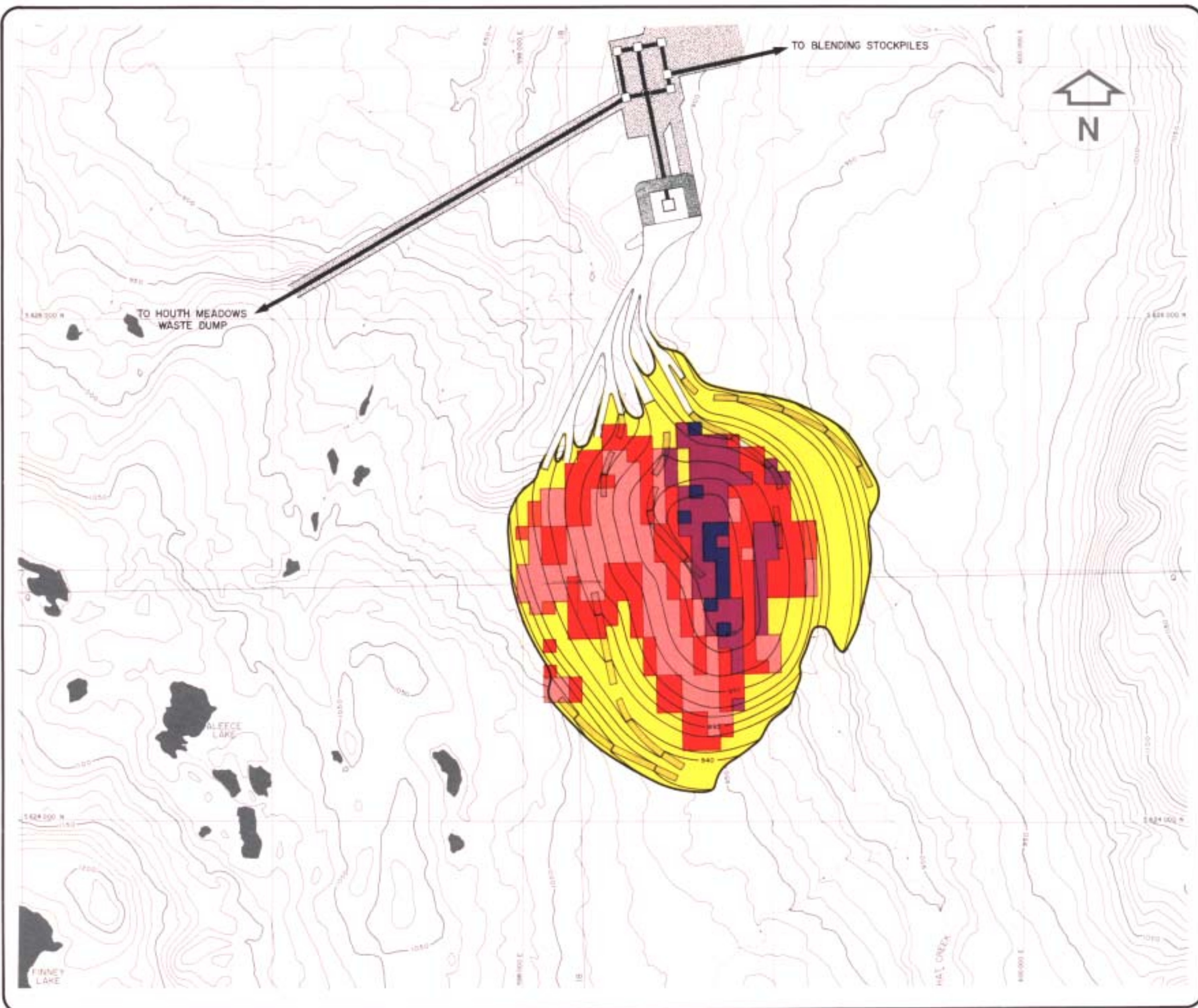


LEGEND

-  MID-BENCH ELEVATION
-  MID-BENCH
-  HAUL ROAD
-  CONVEYOR
-  DUMP STATION
-  CENTRAL DISTRIBUTION POINT
-  TRANSFER POINT
-  FILL

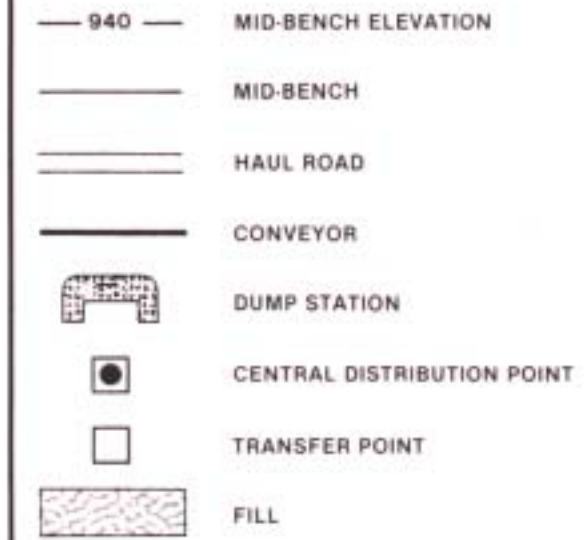
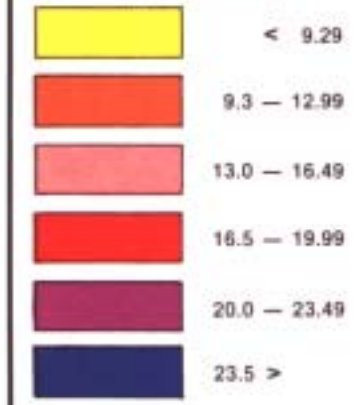
HAT CREEK PROJECT
FIGURE 5-12
Pit Development Year-1

SOURCE: British Columbia Hydro and Power Authority



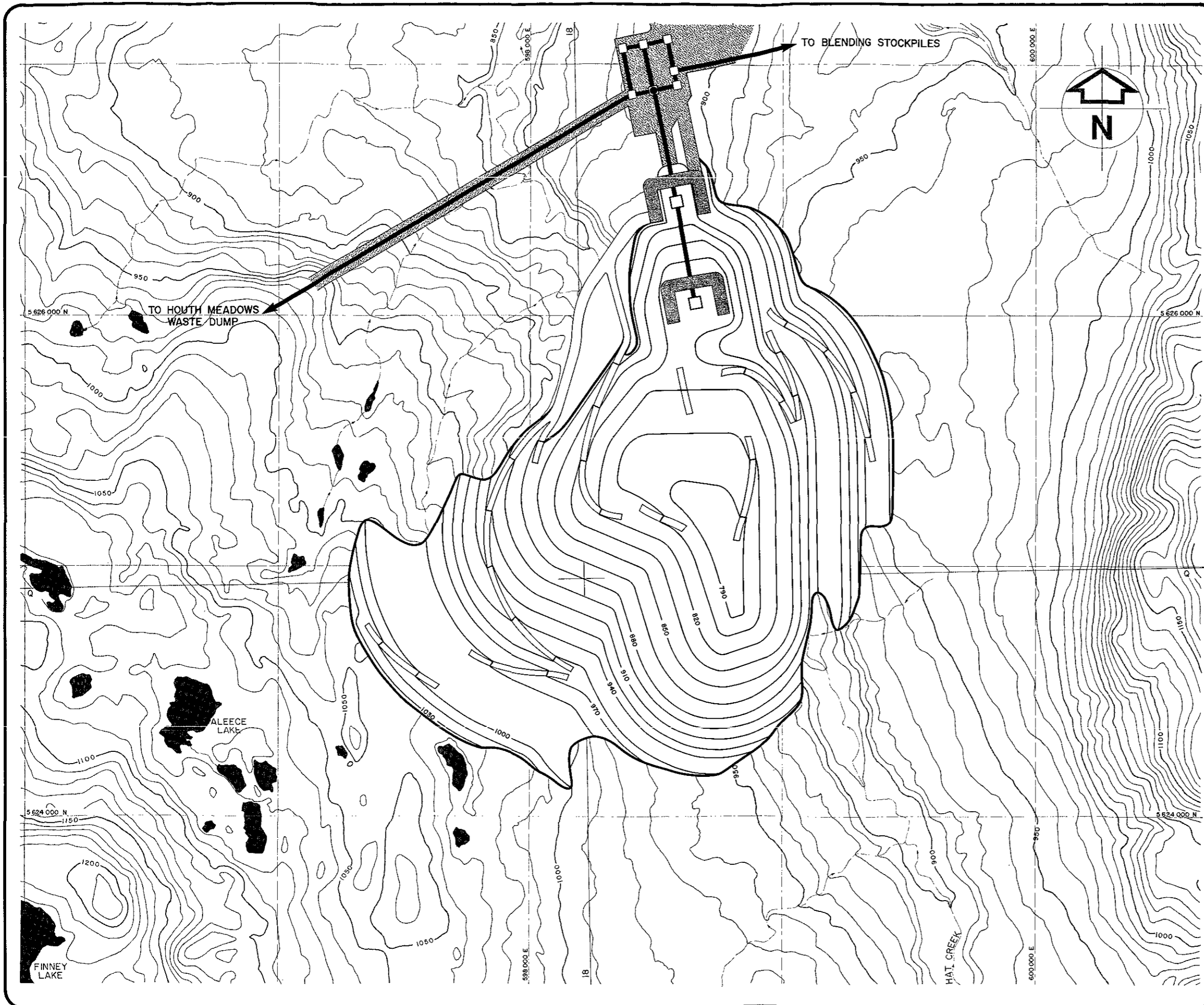
LEGEND

SPECIFIC ENERGY RANGES
MJ/kg (DRY BASIS)



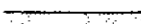




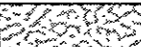


HAT CREEK PROJECT
FIGURE 5-13
Pit Development Year 5

SOURCE: British Columbia Hydro and Power Authority



LEGEND

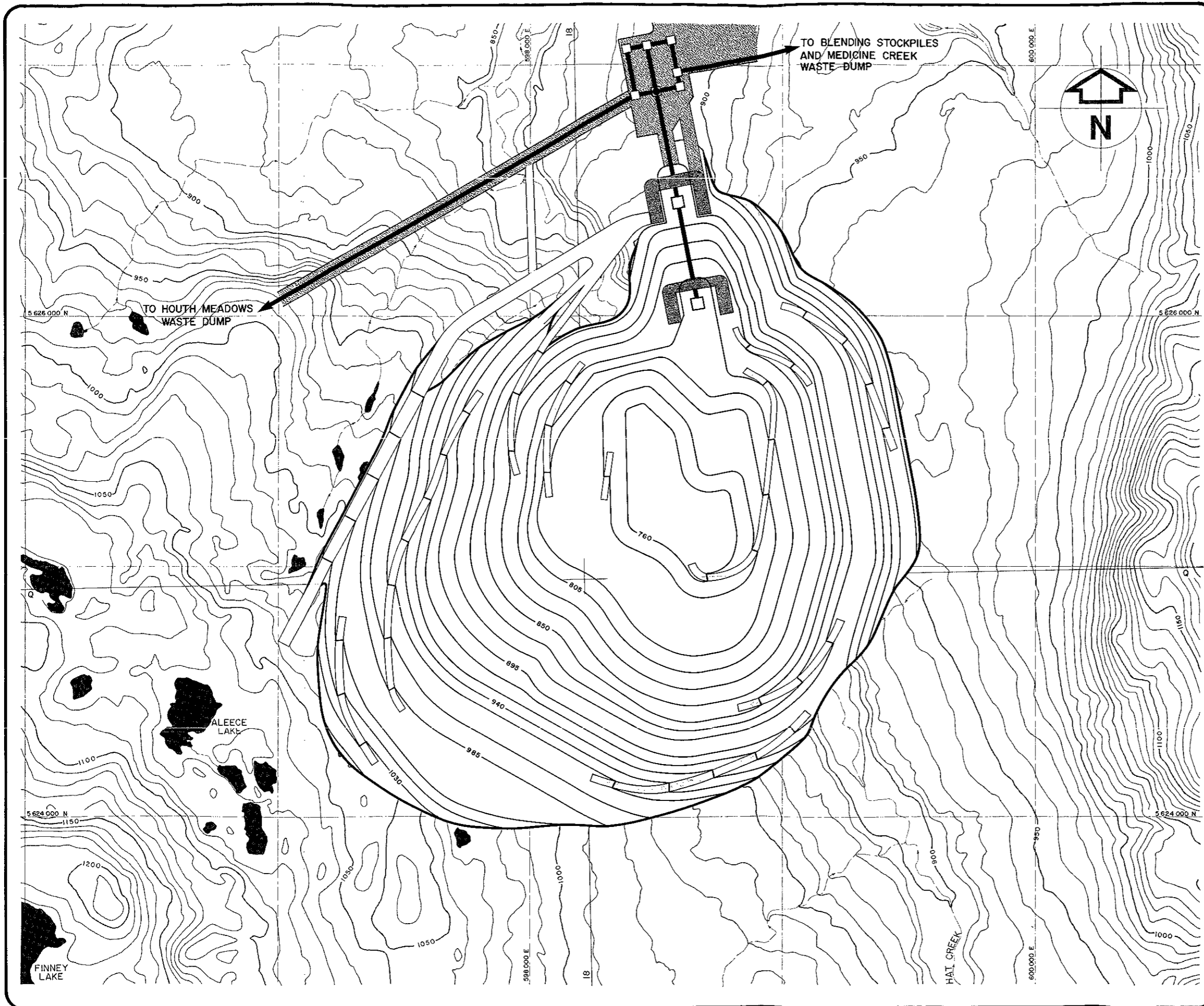
-  MID-BENCH ELEVATION
-  MID-BENCH
-  HAUL ROAD
-  CONVEYOR
-  DUMP STATION
-  CENTRAL DISTRIBUTION POINT
-  TRANSFER POINT
-  FILL

HAT CREEK PROJECT

FIGURE 5-14

Pit Development Year 8

SOURCE: British Columbia Hydro and Power Authority



LEGEND

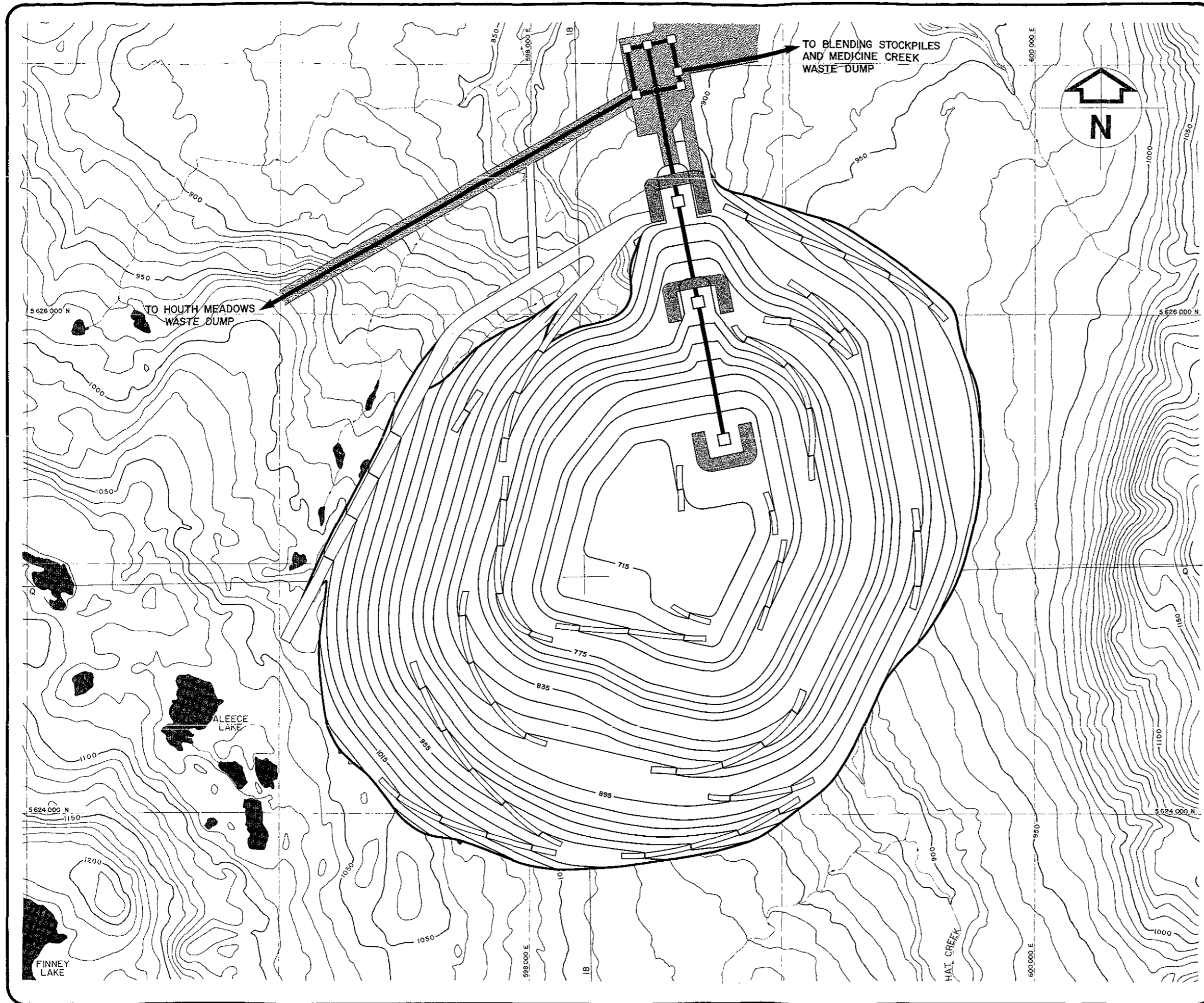
- 850 — MID-BENCH ELEVATION
- MID-BENCH
- ▬ HAUL ROAD
- CONVEYOR
- ⌒ DUMP STATION
- CENTRAL DISTRIBUTION POINT
- TRANSFER POINT
- ▨ FILL

HAT CREEK PROJECT

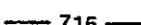






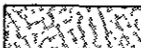
FIGURE 5-15

Pit Development Year 15

SOURCE: British Columbia Hydro and Power Authority

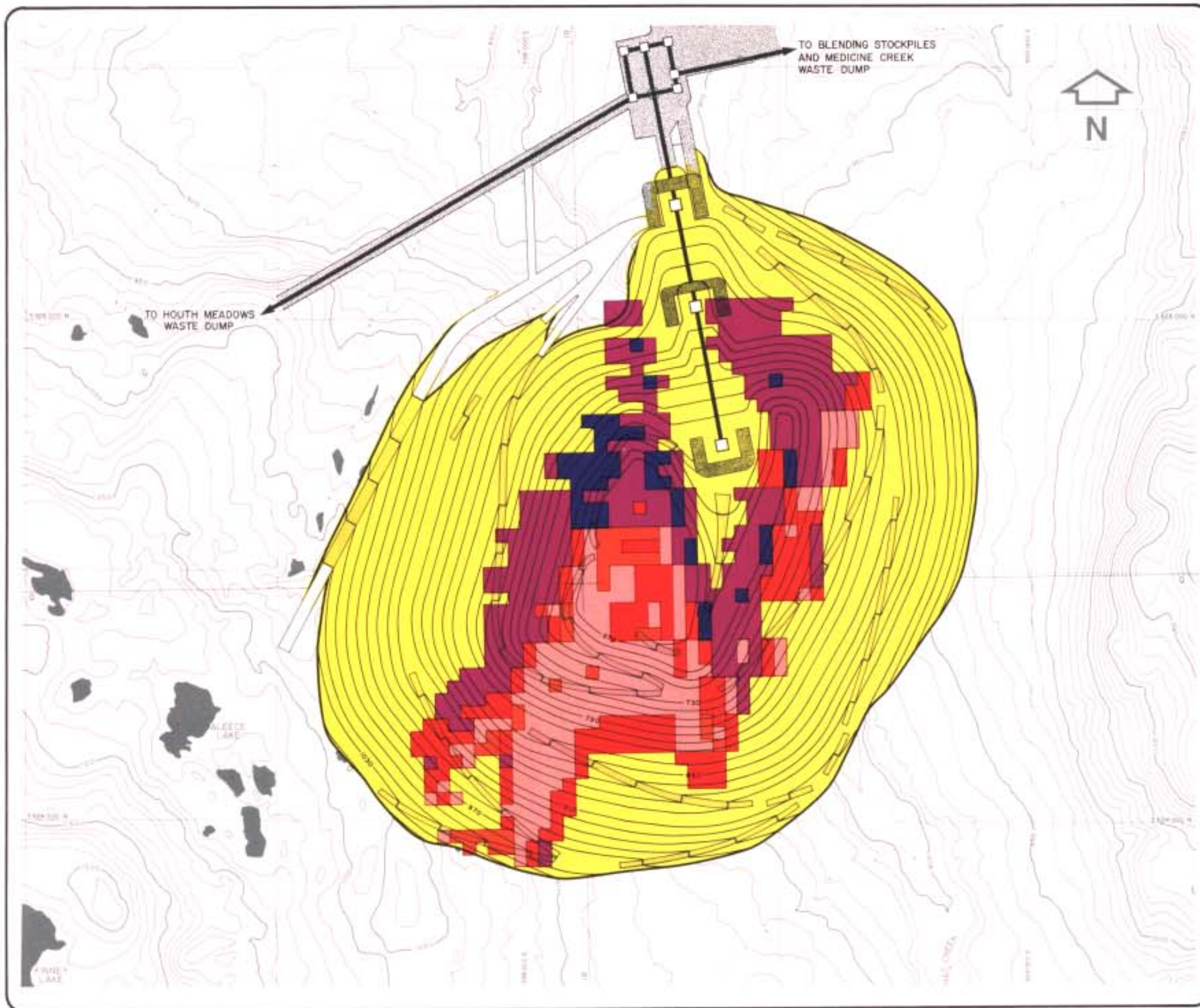


LEGEND

-  MID-BENCH ELEVATION
-  MID-BENCH
-  HAUL ROAD
-  CONVEYOR
-  DUMP STATION
-  CENTRAL DISTRIBUTION POINT
-  TRANSFER POINT
-  FILL

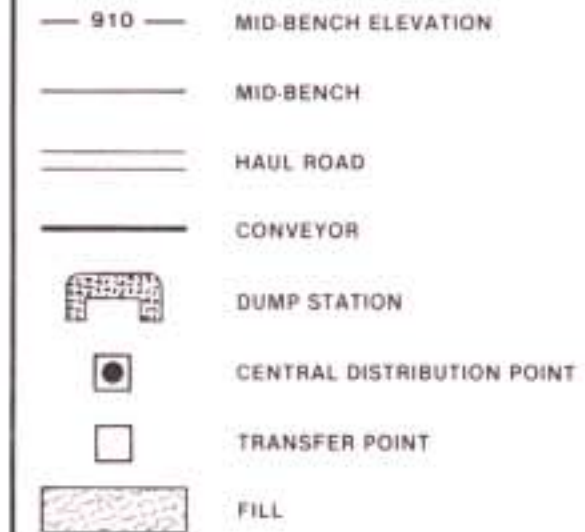
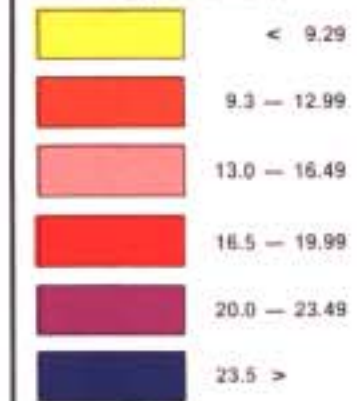
HAT CREEK PROJECT
FIGURE 5-16
Pit Development Year 25

SOURCE: British Columbia Hydro and Power Authority



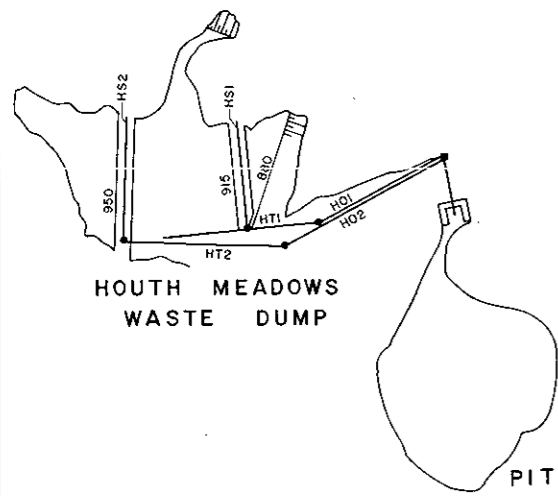
LEGEND

SPECIFIC ENERGY RANGES
MJ/kg (DRY BASIS)

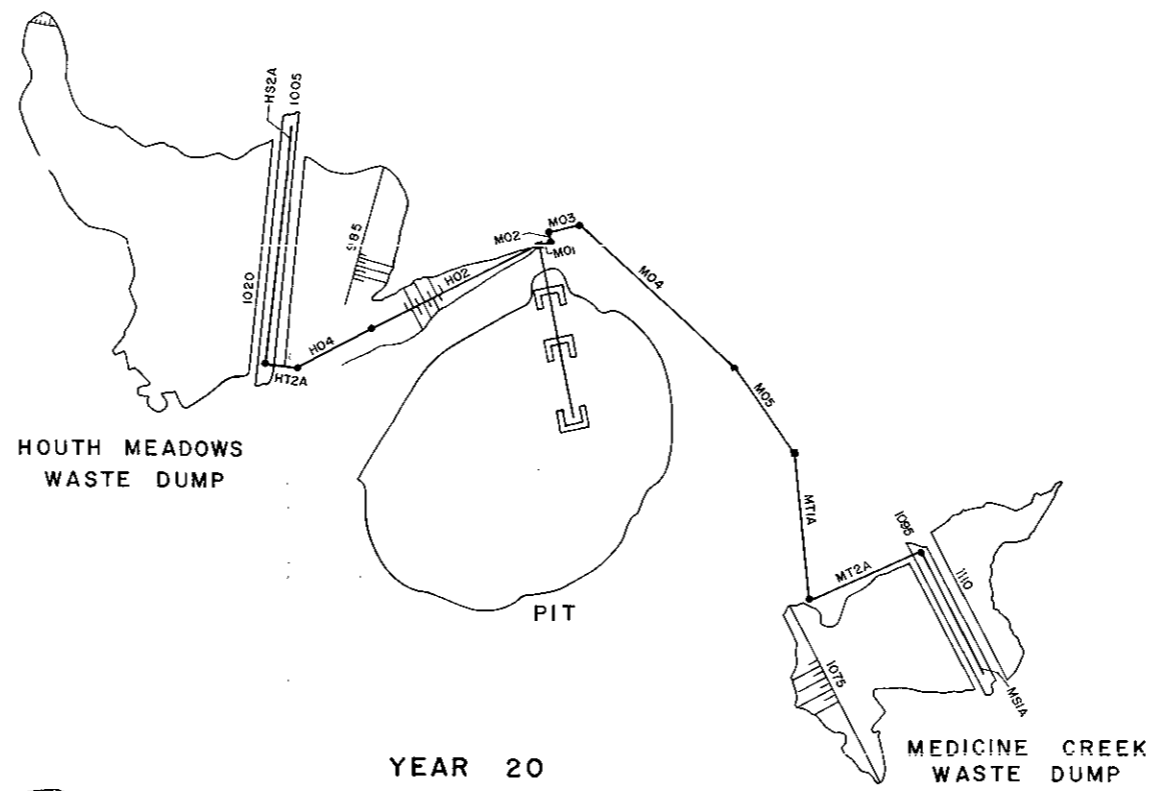


HAT CREEK PROJECT

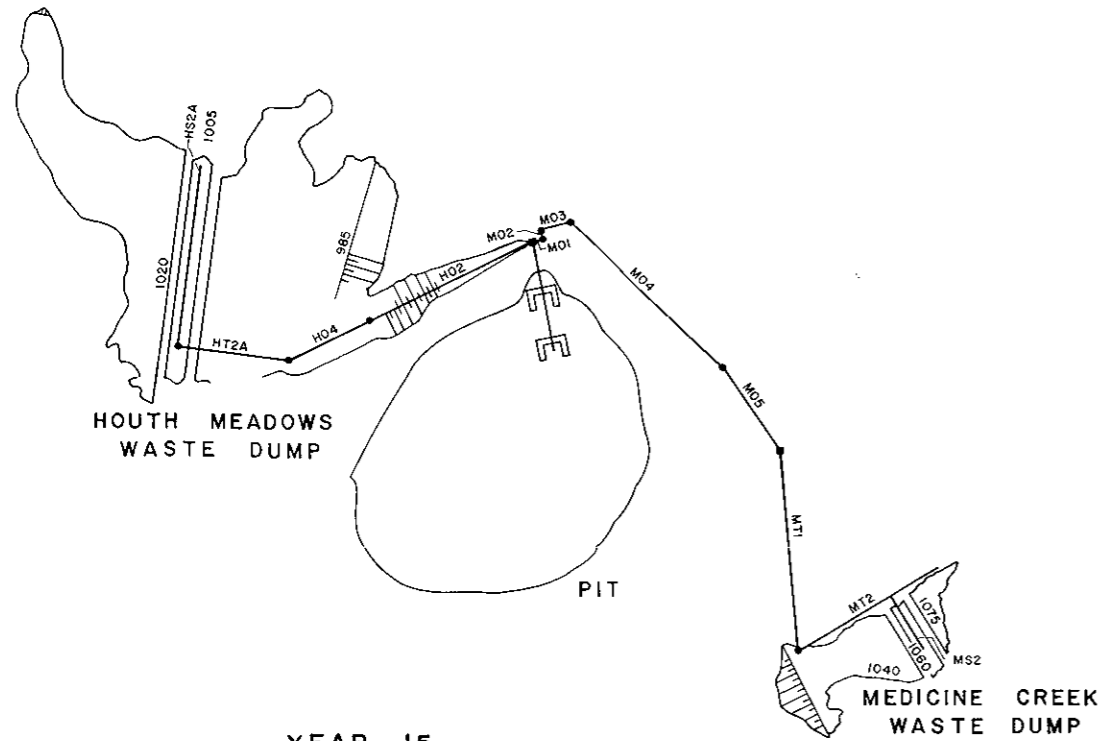
FIGURE 5-17
Pit Development Year 35



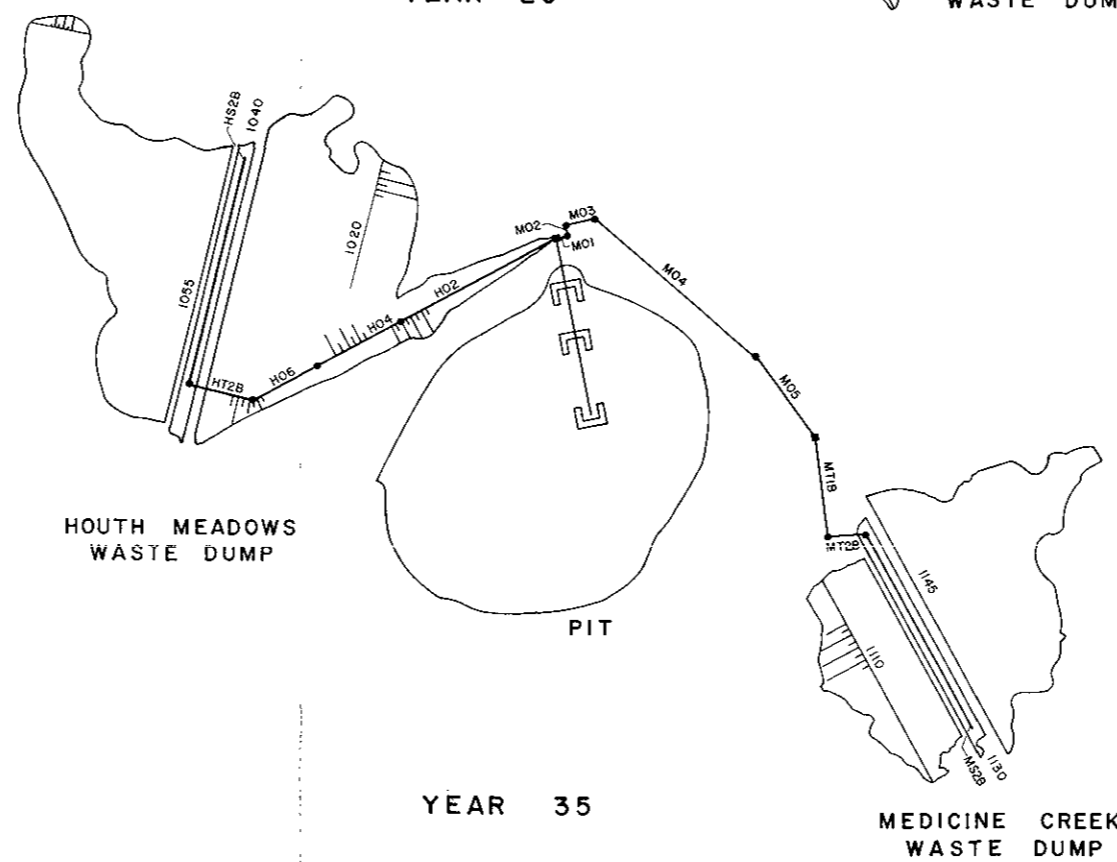
YEAR 5



YEAR 20



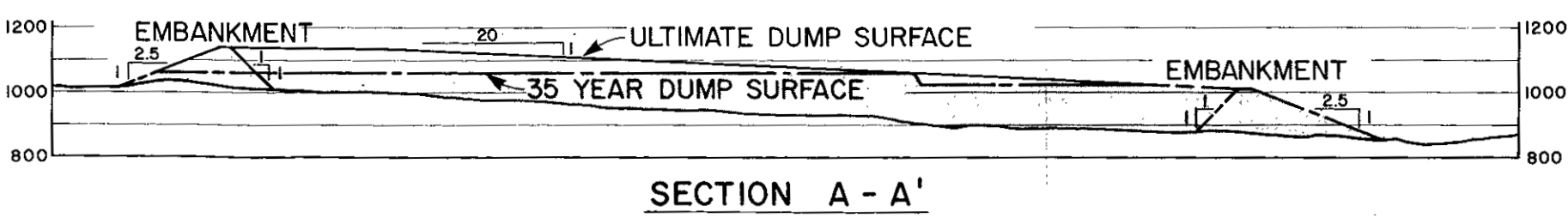
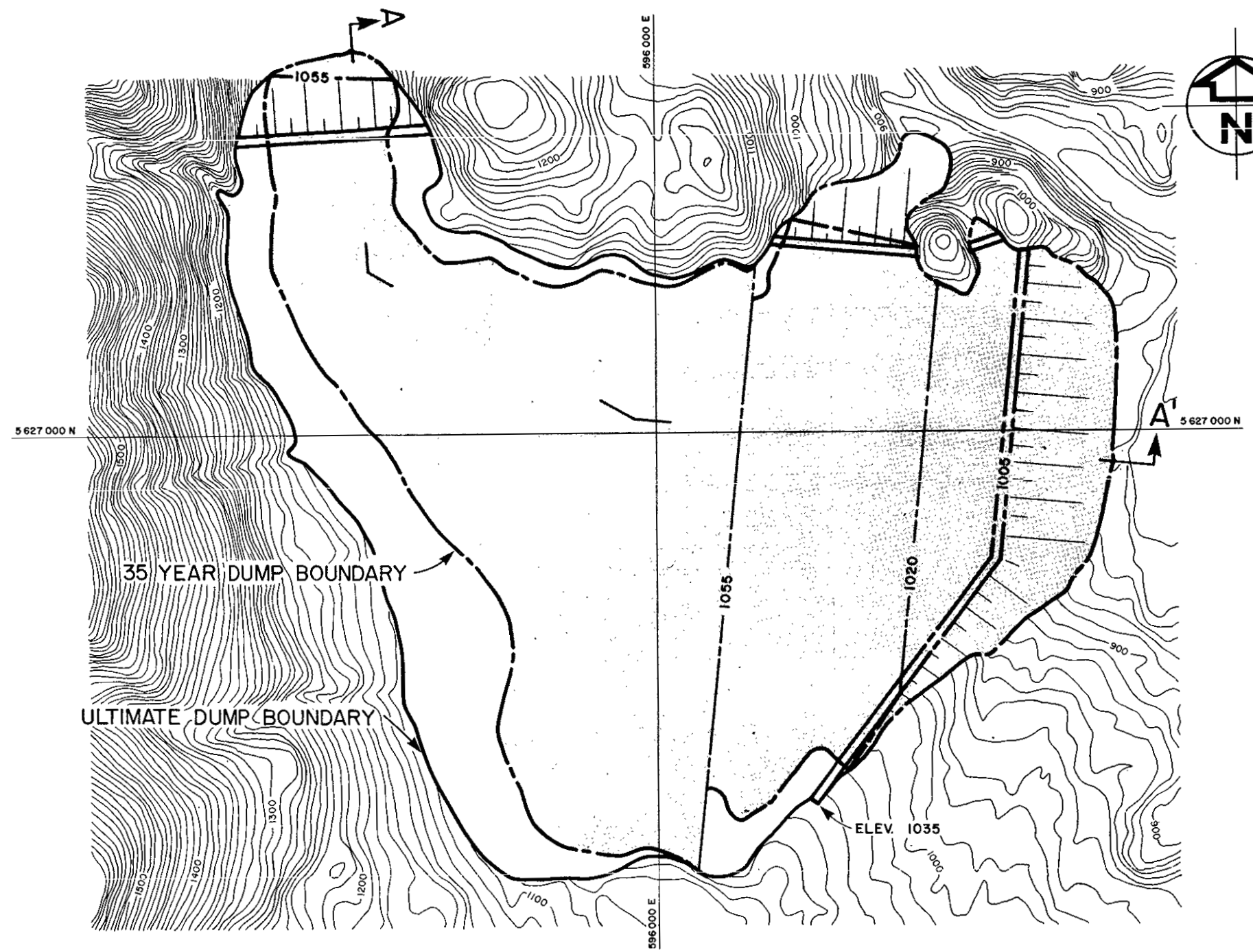
YEAR 15



YEAR 35

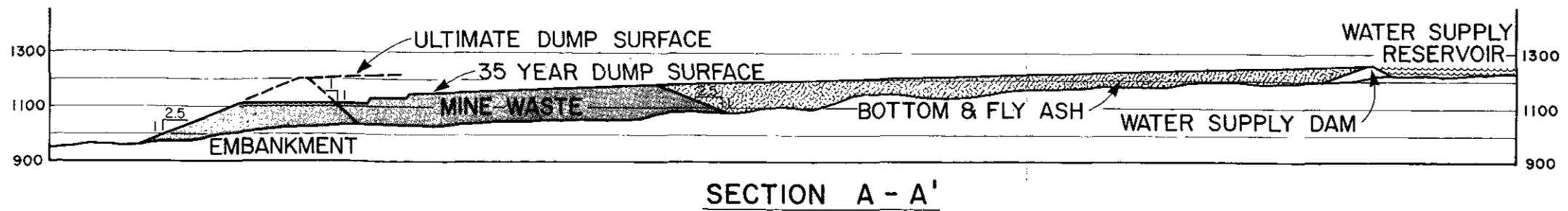
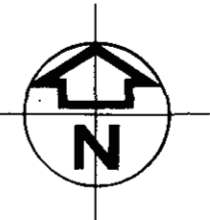
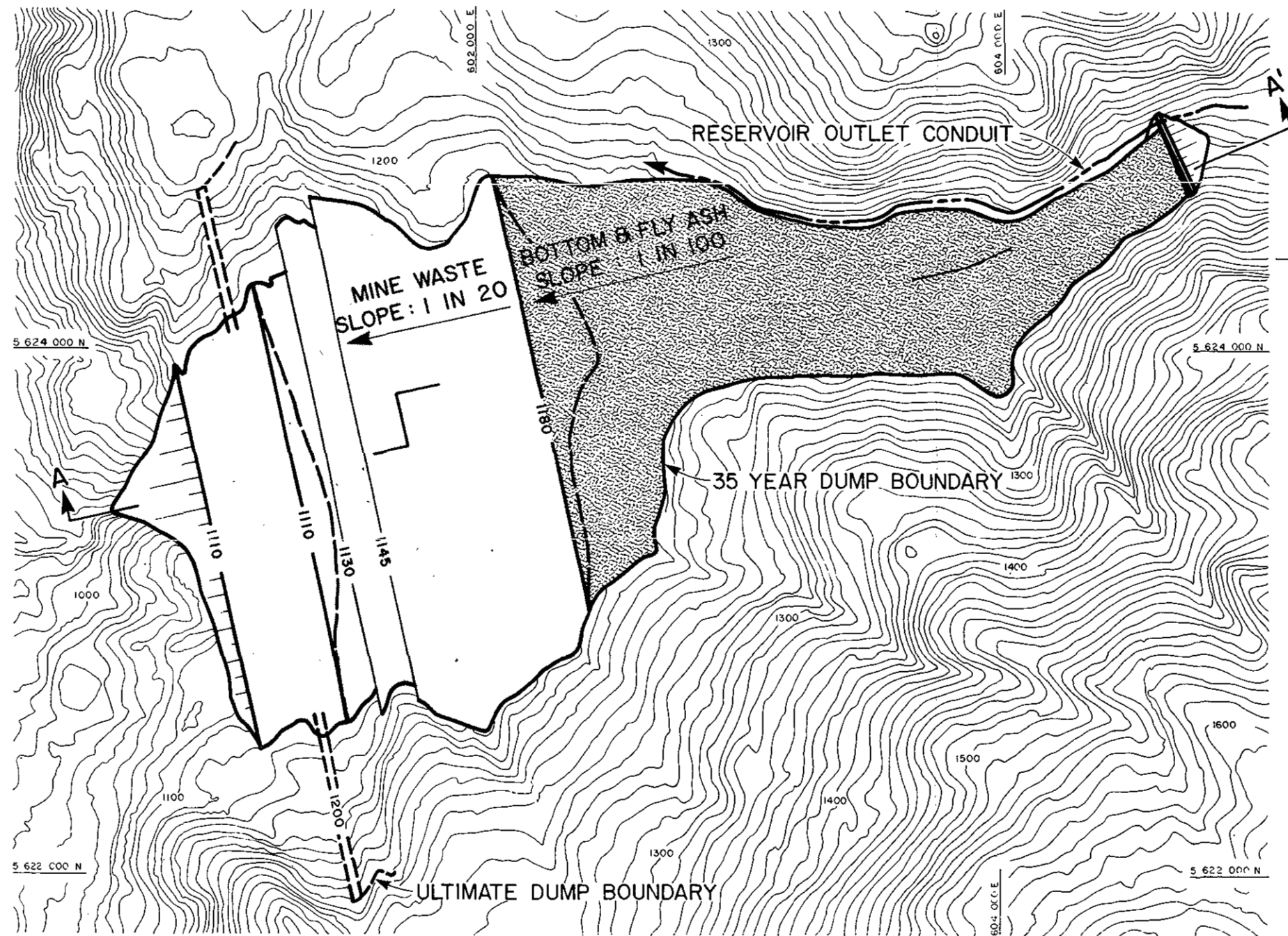
HAT CREEK PROJECT
 FIGURE 5-18
 Waste Dump Development

SOURCE: British Columbia Hydro and Power Authority



HAT CREEK PROJECT
FIGURE 5-19
Houth Meadows Waste Dump

SOURCE: British Columbia Hydro and Power Authority

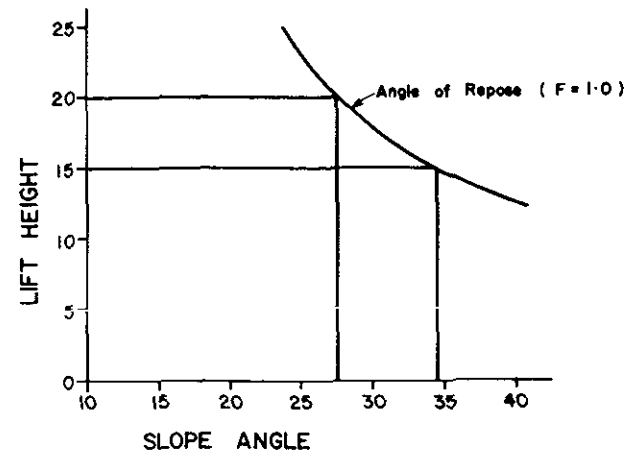


HAT CREEK PROJECT

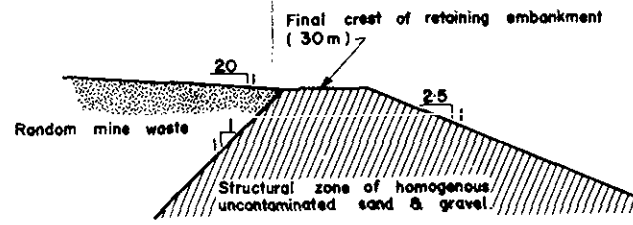
FIGURE 5-20

Medicine Creek Waste Dump

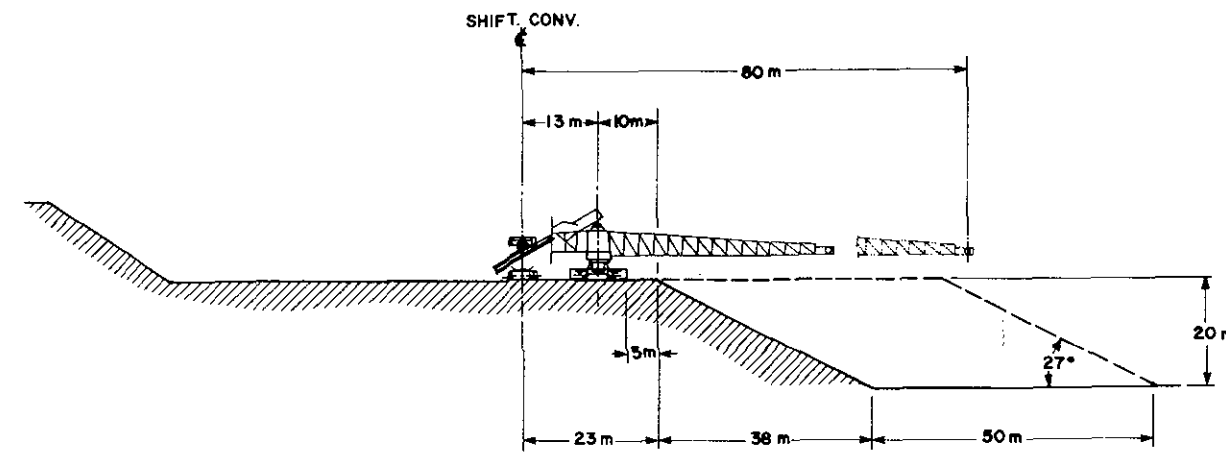
SOURCE: British Columbia Hydro and Power Authority



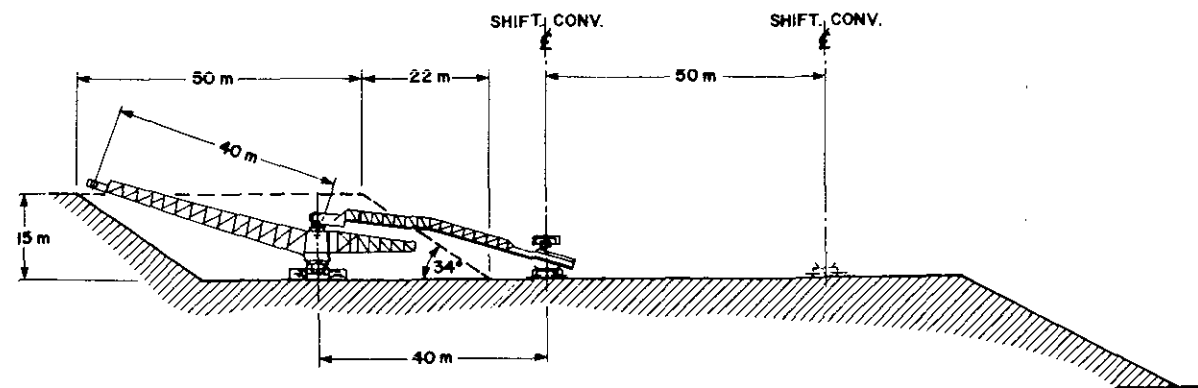
(a) WASTE MATERIAL ANGLE OF REPOSE



WASTE EMBANKMENT SLOPE ANGLES



(b) SPREADER POSITIONED TO DEPOSIT WASTE BELOW THE SHIFTABLE CONVEYOR



(c) SPREADER POSITIONED TO DEPOSIT WASTE ABOVE THE SHIFTABLE CONVEYOR

HAT CREEK PROJECT
 FIGURE 5-21
 Waste Dump Slopes

SOURCE: CMJV/Golder Associates

| 6 | <u>THE MINE DRAINAGE PLAN</u> | <u>Page</u> |
|-----|--|-------------|
| 6.1 | Introduction | 1 |
| 6.2 | Mine Water: Source and Quality | 2 |
| | 6.2.1 Direct Precipitation and Runoff | 2 |
| | 6.2.2 Creeks, Lakes, and Ponds | 3 |
| | 6.2.2.1 Creeks | 3 |
| | 6.2.2.2 Lakes and Ponds | 3 |
| | 6.2.3 Groundwater | 4 |
| | 6.2.4 Mine Wastewater | 5 |
| 6.3 | Mine Drainage System | 6 |
| | 6.3.1 Design Criteria | 6 |
| | 6.3.2 Drainage of the Mine Development | 7 |
| | 6.3.2.1 The Open Pit | 7 |
| | 6.3.2.2 South-West Slide Area | 8 |
| | 6.3.2.3 Houth Meadows Waste Dump | 10 |
| | 6.3.2.4 Medicine Creek Waste Dump | 11 |
| | 6.3.2.5 Coal Blending Area | 12 |
| | 6.3.2.6 Low-grade Stockpile | 12 |
| | 6.3.2.7 Topsoil Storage Areas | 12 |
| | 6.3.2.8 Mine Services Area | 12 |
| | 6.3.2.9 Mine Roads | 13 |
| | 6.3.2.10 Sewage | 13 |
| 6.4 | Wastewater Disposal | 14 |
| | 6.4.1 Discharge Objectives | 14 |
| | 6.4.2 Projected Quality of Mine Drainage | 14 |
| | 6.4.3 Proposal Treatment to Meet Objectives | 16 |
| | 6.4.3.1 Zero Discharge System | 16 |
| | 6.4.3.1.1 General | 16 |
| | 6.4.3.1.2 Inflow, Outflow, and Lagoon Capacity | 16 |
| | 6.4.3.1.3 North Valley Lagoon | 17 |
| | 6.4.3.1.4 Medicine Creek Valley Lagoon | 18 |
| | 6.4.3.1.5 Operation | 19 |
| | 6.4.3.2 Sedimentation Lagoon System | 19 |
| | 6.4.3.2.1 General | 19 |
| | 6.4.3.2.2 Design Criteria | 20 |
| | 6.4.3.2.3 Inflow | 20 |
| | 6.4.3.2.4 Sediment Tests | 20 |
| | 6.4.3.2.5 North Valley Lagoons | 21 |
| | 6.4.3.2.6 Medicine Creek Lagoons | 21 |
| | 6.4.3.2.7 Lagoon Discharge | 22 |
| | 6.4.3.2.8 Operation | 23 |

| <u>No.</u> | <u>LIST OF TABLES</u> | <u>Page</u> |
|------------|---|-------------|
| 6-1 | Projected Groundwater Yield from the Mine Development | 24 |
| 6-2 | Design Criteria for Planning of the Mine Drainage System | 25 |
| 6-3 | Design Flows for Preliminary Planning of the Mine Drainage System | 26 |
| 6-4 | Projections of Water Quality of Mine Drainage | 27 |
| 6-5 | Estimated Sedimentation Lagoon Inflow: Year 35 | 28 |
| 6-6 | Projected Quality of Lagoon Discharge and Hat Creek - Case III | 29 |

LIST OF FIGURES

| | | |
|-----|--|----|
| 6-1 | Precipitation Data | 30 |
| 6-2 | Streamflow Data | 31 |
| 6-3 | Mine Drainage Schematic | 32 |
| 6-4 | Mine Drainage Plan | 33 |
| 6-5 | Zero Discharge Hydrographs - Year 35 | 34 |
| 6-6 | Sedimentation Lagoons: Mean Monthly Discharge | 35 |
| 6-7 | Sedimentation Lagoons: 10-Year 24-Hour Flood Discharge Hydrographs | 36 |

SECTION 6

THE MINE DRAINAGE PLAN

6.1 INTRODUCTION

Without effective mine drainage, no open-pit mining operation on the scale of Hat Creek could hope to succeed; nor could it satisfy today's stringent environmental requirements. The Mine Drainage Plan devised as a result of painstaking studies by our consultants, Cominco-Monenco Joint Venture, does both (CMJV 1979). It is believed to be a comprehensive mine drainage plan which provides for environmental protection in initial mine planning. Its objectives are:

1. to keep the mine dry enough to ensure continuous operation;
2. to prevent flood damage to both excavations and equipment;
3. to ensure the stability of slopes and embankments;
4. to protect the environment by providing for the continuity of existing streams, preventing the discharge of harmful water-borne contaminants, and ensuring that all applicable regulations are observed.

This report covers in detail all elements of the Hat Creek Mine Drainage Plan during the first 35 years' mining of the No. 1 Deposit, and the continuing measures after the mine has closed to ensure that the environment is restored as nearly as possible to its former condition.

6.2

MINE WATER: SOURCE AND QUANTITY

The principal sources of drainage flow within the mining area are:

1. Direct precipitation and runoff;
2. Creeks entering the mine site;
3. Standing surface water in lakes and ponds;
4. Groundwater flow;
5. Wastewater from mine operations.

6.2.1

Direct Precipitation and Runoff:

Annual precipitation at the mine site is low, averaging 317 mm/a, of which 55% is received as rain and the balance as snow. Summer and Winter are the wettest seasons, with Spring and Fall being somewhat drier. Figure 6-1 shows the seasonal variation of precipitation and the frequency of annual and 24-hour precipitation. Roughly 16% of the annual precipitation which falls in the valley appears as stream-flow, which indicates a high loss of moisture to infiltration and evapotranspiration. Most runoff occurs in Spring and early Summer, the most intense rainstorms in mid-Summer. Flood hydrographs show that only 24% of the precipitation appears as direct runoff due to the high storage potential of the surface cover and high losses to evapotranspiration (Beak 1978). Mining activities are expected to reduce this surface storage capability and increase the runoff, resulting in increased peak flow rates from the watersheds. Maximum flow rates are expected during high intensity rainfall in Summer, calculated by the method used by the USDA Soil Conservation Service (1964). This volume of runoff is correlated to peak flow rates which have been assembled from field data for small agricultural watersheds (USDA SCS 1975).

Surface runoff at the top of the active waste dumps is expected to be negligible. Leachate from waste dumps, which is expected to be low due to the low hydraulic conductivity of dumped waste, will be collected at the toe of the downstream waste embankments. Seepage and runoff from the coal and waste rock strata within the pit will be of similar quality to the stockpile and waste dump effluents. An average water yield of 80 mm has been assumed for these areas, giving mean annual flows of 0.003 m³/s - 0.01 m³/s during the lifetime of the mine. Flow rates for waste dump leachate and pit seepage as estimated by Golder in 1979 are presented in Table 6-1.

6.2.2 Creeks, Lakes and Ponds:

6.2.2.1 Creeks:

The principal creeks flowing through the proposed mine area are Hat Creek, Medicine Creek, Houth Creek, and Finney Creek. Of these, Hat Creek is the largest, and flows have been continuously recorded since 1960. Figure 6-2 shows the range of monthly variation of Hat Creek. Flow gauges established in four other creeks in 1977 have as yet produced insufficient data to provide statistical analysis of flows, but such data as do exist indicate that the flow regimes are similar to that of Hat Creek. Flood frequency curves derived from regional streamflow data are shown on Figure 6-2.

The proposed development of the open pit will require diversion of flows from various small watersheds and tributary creeks. Regional streamflow data shown as a flood nomograph gives estimates of flood flows for watersheds greater than 10 km² in area.

6.2.2.2 Lakes and Ponds:

Most lakes and ponds in the project area occur on the West side of Hat Creek Valley. There are approximately 80 small lakes and ponds to the West of the proposed pit perimeter.

Geotechnical studies of this area have identified both active and inactive slide masses in the overburden which may cause instability of the West pit slope during mining (Golder 1977, 78/79). Stabilization measures require that Aleece Lake and 61 other lakes and ponds be drained. Finney Lake and 15 other small ponds lie in a more stable and remote area, and therefore drainage is not considered essential at the outset of the project. Monitoring of the slide during mining should give an advance indication of any need to drain Finney Lake and these other ponds. Fifteen to 20 small lakes and ponds in the Houth Meadows Waste Dump Area should be drained prior to being covered with waste.

6.2.3 Groundwater:

Studies to date have identified three major geohydrologic units within the general mine area (Golder, 1978) which comprise:

- (1) the surficial deposits, which vary from slide debris and till in the West to gravels in the East. This is the major waterbearing unit of highest average conductivity 10^{-6} m/s;
- (2) the coal, which exhibits highly variable conductivity, estimated to average 5×10^{-9} m/s;
- (3) the upper and lower Coldwater sediments which are essentially impermeable with an average conductivity of 5×10^{-11} m/s.

General groundwater flow within the Upper Hat Creek Valley recharges in upland areas and discharges in the valley bottom. Most of the groundwater flows through surficial deposits. Less than 2% is estimated to move through clastic sediments in the valley bottom.

The Eastern areas are reasonably well drained due to the greater depths of surficial deposits, whereas they are thinner in Western areas in addition to being of lower permeability.

The two main aquifers in the pit area are a small alluvial aquifer along the central valley and a buried bedrock channel on the East side of the valley, flow of which is estimated to be in the area of 3×10^{-2} m³/s.

Due to the low permeability of the coal and bedrock units, water yield from seepage and draining operations during mining is predicted to be minimal (Golder, 1978). Extensive depressurization of pit slopes is not likely, and dewatering wells will therefore be selectively located in pervious zones, where higher benefits can be realized.

Flow from peripheral dewatering wells is estimated to be 0.02 m³/s one year prior to commencement of mining, decreasing to a steady rate of 0.017 m³/s throughout the remainder of the project. Groundwater which by-passes this system and appears as seepage in the pit is expected to average 0.0047 m³/s, of which 0.0037 m³/s would seep from the surficial deposits and 0.001 m³/s from the bedrock zone at the base of the pit (Golder, 1979, Appendix 2).

6.2.4 Mine Wastewater:

Three main sources of wastewater produced by the mining operations have been identified:

1. effluent from the Mine Services Area;
2. runoff and leachate from coal-handling areas, waste dumps, and low-grade stockpiles;
3. runoff and seepage from coal and bedrock strata in the open pit.

The major source of waste from the Mine Services Area will be sanitary effluent from the daily work force peaking at about 700 persons. The mean daily flow is estimated at 140 m³/d, plus an allowance of 90 m³/d for vehicle washdown and general use.

Runoff and leachate from coal and low-grade stockpiles will require special drainage and disposal systems due to the predicted high levels of dissolved salts. (B.C. Hydro Thermal Division 1979 - 1978 Environmental Field Program.) Water yield from the 33 ha Low-grade Coal Stockpile is expected to average 50 mm/a, with the 22 ha Coal Blending Area yielding an estimated 80 mm/a. These yields correspond to annual volumes of 16,500 m³ and 17,600 m³ respectively.

The overburden and waste rock material from the open pit will be retained in valley-fill type dumps in Houth Meadows and Medicine Creek Valley. Any runoff and leachate from mine waste disposal areas will require a special drainage system because of the predicted level of dissolved solids and trace elements in excess of regulatory guidelines for discharge to streams (Beak, 1978/79).

6.3

MINE DRAINAGE SYSTEM:

The proposed mine drainage system will consist of:

1. Diversion canals to divert creeks which flow through the mine site;
2. Perimeter drains around the open pit, slide area, and waste dumps;
3. Dewatering wells around the pit perimeter and the unstable slide area;
4. Surface water drains to collect stormwater in the pit and mine service areas;
5. Field drains to collect leachate from waste dump and stockpiles;
6. Sanitary sewers to collect sewage from the Mine Services Areas.

A schematic of the system is shown on Figure 6-3 and a geographic layout plan on Figure 6-4.

6.3.1

Design Criteria and Selection of System Capacity:

The calculation of system capacity has taken into account the risk of flood damage, should the system fail. Design criteria are shown on Table 6-2 and design flows for the system on Table 6-3. The larger drains or canals have been designed on the basis of the 1,000-year average return period flood, which has a 3% chance of being exceeded during the 35-year mining period. Smaller components are designed to withstand lesser flood risk.

6.3.2 Drainage of the Mine Development:

6.3.2.1 The Open Pit:

1. Diversion of Hat Creek and Finney Creek:

To prevent flooding the excavation, Hat Creek and Finney Creek must be diverted.

The Hat Creek Diversion will consist of a headworks dam with a canal intake and an emergency spillway located downstream of Anderson Creek; approximately 6.4 km of diversion canal on the East side of Hat Creek Valley; and 1.9 km of buried conduit with intake and outlet works to convey the flow back to Hat Creek. A pit rim dam, spillway, pumphouse, and pipeline between the headworks dam and the minepit will intercept seepage and local inflow immediately upstream of the pit. The diversion works have been designed to accommodate a flow of 18 m³/s (100-year recurrence interval flood), and, as an emergency condition, a flow of 27 m³/s (100-year recurrence interval flood). The proposed Finney Creek Diversion Canal is 2.75 km long and will divert Finney Creek flows South, along the West side of Hat Creek, with discharge to the Hat Creek Diversion Headworks Pond. The design capacity of the canal is 5.5 m³/s, which is also based on the estimated 1,000-year recurrence interval flood.

2. Perimeter Drainage:

The open pit will be surrounded by approximately 6 km of open perimeter drainage ditches, some of which are illustrated in Figure 6-4. The drain to the North-East will collect runoff from areas of heavy traffic for discharge to sedimentation lagoons North of the mine. North-West of the open pit, an open drain will discharge to the buried drainage pipe located in the conveyor causeway. To the South of the mine there will be three similar drains: the upper South-West perimeter drain, which discharges to the Finney Creek Canal; and the lower South-West and South-East perimeter drains, which discharge to the pit rim reservoir.

3. In-Pit Surface Water Drainage:

Surface water and seepage will be collected in open bench drains alongside bench haul roads. Runoff and seepage from surficial material above the mouth of the mine will flow by gravity to the North end of the pit, where it will be collected and discharged to sedimentation lagoons. Runoff from surficials below the mouth of the mine will be collected by bench drains, discharged to small pump sumps and raised to upper gravity bench drains by portable pumps. The lining of major bench drains will probably be required. Runoff and seepage from coal and bedrock strata in the base of the pit will drain via bench drains to sumps located near the main pit access. Temporary sumps and pumps will be placed in low areas on the floor of the pit to collect and remove accumulations of water. A major system of pumps will be installed on the pit incline. This system will discharge to a leachate storage lagoon to the North of the pit. During Summer, water tankers used for dust suppression on bench and haul roads will be filled directly from sumps within the pit.

4. Dewatering Wells:

A staged program of groundwater withdrawal is planned:

| | |
|----------------------------|---|
| <u>Starting in Year 5:</u> | Two systems of wells will be drilled, 25 inside the perimeter, and 10 to 15 outside; |
| <u>Year 10 to Year 15:</u> | A final set of wells will be established beyond the perimeter of the 35-year pit. By Year 15, 75 pairs of wells should have been drilled and be operating, one deep and one shallow in each pair. |

Total water yield is expected to be low - an average of 0.017 m³/s or 1,470 m³/d (Golder, 1979), and while surface water may be discharged to Hat Creek via sedimentation lagoons, water from wells in coal or clastic sedimentary rock will have to be collected in drainage sumps along with surface runoff and pumped to leachate storage lagoons.

6.3.2.2 South-West Slide Area:

Geotechnical studies have determined that stabilization of the slide areas to the South and South-West will depend primarily on

drainage (Golder, 1979). Surface water drainage will be required to prevent the groundwater system re-charging, and sub-surface drainage to drain or de-pressurize the groundwater.

1. Perimeter Drainage:

Two diversion drains will minimize surface runoff from small creeks and watersheds at the back of the slide. The North Slide Diversion will be a 1.5 m³/s capacity open drain 1.7 km long, discharging to the West perimeter drain near the South-West corner of the Houth Meadows Waste Dump. The South Slide Diversion will be an 0.75 m/s capacity open drain 1.2 km long, discharging to the North end of Finney Lake.

Diversion drains will either be fully lined or lined on the downstream side with a layer of impermeable soil to minimize seepage.

2. Surface Drainage Within The Slide Area:

The system will drain approximately 62 small lakes and ponds by improving natural drainage channels and deepening outlets. Drainage will be carried out prior to coal production.

The slide area uphill and to the West will be drained to the West Perimeter Drain via two secondary drains - one draining the existing lake chain, the other draining the series of hollows above the active slide area.

Draining the active slide area will require deepening and improving existing channels down the slide, which will drain to the surface water collection system at the North end of the upper pit benches and ultimately discharge to the North valley sedimentation lagoons. The area to the South and South-West contains a system of lakes and hollows, the existing channels of which will require deepening and improving. The area downhill of the South-West Perimeter Drain will be drained by a secondary drain system joining Finney Creek at its diversion point.

3. Well System:

Provision has been made, for a 20-well system and three km of collector piping, which would be buried to allow for a year-round use (Golder, 1979).

6.3.2.3

Houth Meadows Waste Dump:

1. Perimeter Drainage:

During construction, surface water from the Upper Houth Meadows Watershed will be diverted around the dump via the West Perimeter Diversion. This diversion consists of a 5 km x 8 m wide open drain, with discharge to a buried pipe 2.2 km in length in the conveyor causeway. This pipe will drain into Hat Creek, North of the mine.

The diversion is designed to carry the 1,000-year flood, and a typical cross-section is shown in Figure 6-4. The channel will be unlined on minor gradients. On steeper gradients, a riprap lining will be laid to prevent scour. Though icing may occur, no special design configurations are deemed warranted.

Two further small perimeter drains will be constructed on the North slopes of Houth Meadows, which will discharge to the Marble Canyon Watershed.

2. Drainage of Lakes:

Approximately 20 small lakes and ponds within Houth Meadows will be drained before dump construction. Since these lakes are expected to be high in nutrients, their draining would be carried out during freshet, in order to prevent enrichment of creeks.

3. Surface Water Collection:

During construction of the dump, it is expected that the surface of the waste will be undrainable and that the precipitation will be trapped and lost primarily to evaporation. Minor drainage below the perimeter drains will be collected by an open drain and discharged to the North valley sedimentation lagoons by a buried pipe in the conveyor causeway. During operation of the waste dump, this drain will dispose of surface water from the conveyorway and service roads. Drainage from the re-claimed dump surface will be channelled to this drain by small diversion dykes or swales.

4. Leachate Collection:

Leachate from the main waste embankment will be collected by a line of perforated subsoil drains and discharged to the leachate storage lagoon in the North valley. Monitoring of water quality downstream may be advisable to determine whether de-watering wells should be installed to return leachate to the dump surface for disposal by evaporation.

6.3.2.4 Medicine Creek Waste Dump:

1. Perimeter Drainage:

The Medicine Creek Valley would be extensively used by this project. The powerplant reservoir would be constructed in the Eastern portion of the upper valley. Canals would be constructed to collect runoff from the downstream area, directing it to the reservoir starting in Year 1. Powerplant ash would be dumped in the valley immediately adjacent to the reservoir. In Year 16, mine waste would be dumped in the valley, but starting from the Western end.

During the first 15 years, runoff and seepage from the ash disposal area would be collected in the valley bottom and pumped to a powerplant holding pond for use in dust control. Normal runoff in the lower valley would enter the Hat Creek diversion directly. Once mine waste disposal commences, two minor sidehill drains will be constructed to direct small amounts of runoff occurring below the major collection canals.

2. Surface Water Drainage:

A special collection system will be constructed to collect runoff and treat it for sediment control before discharge.

3. Leachate Collection:

Leachate will be collected by a perforated subsoil drain and discharged to a leachate storage lagoon for Summer disposal by spray irrigation on the active dump surface.

6.3.2.5 Coal Blending Area:

This covers an area of 22 ha and consists of four stockpiles totalling 15 ha. A compacted till blanket overlain by a pervious sand and gravel drainage layer will form the foundation of the stockpiles. Surface water and leachate will be drained to the North-West perimeter, from where it will be collected and piped to a leachate holding pond for temporary storage before final disposal by re-cycling for dust control within the mine.

6.3.2.6 Low-Grade Coal Stockpile:

This should consist primarily of claystone material with a varying percentage of coal, which will be compacted as it is placed. The permeability will, therefore, be low. Non-active stockpile surfaces will be covered by a non-sodic buffer material and suitable surface soil for re-planting. Runoff and leachate will be collected in a sump and discharged to a leachate lagoon.

6.3.2.7 Topsoil Storage Areas:

Surface water will be diverted from the upper perimeters by small ditches to minimize erosion. The stockpile surface will be progressively re-planted, which will both minimize erosion and avoid contamination of downstream surface water.

6.3.2.8 Mine Services Area:

To collect surface runoff from the Mine Services Area, yards will be sloped to open drains at the perimeter, and drainage around buildings will be handled in buried stormwater drains. Drainage will be channelled West to the main sedimentation lagoons via primary treatment to remove sediment and oil.

6.3.2.9 Mine Roads:

Major roads in the North-West and North-East quadrants of the mine area and within the pit will drain to sedimentation lagoons for primary treatment. Roads to the South will drain to a temporary sedimentation lagoon. Temporary construction and haulage roads will drain to the Medicine Creek Sedimentation Lagoon via a buried conduit beneath the Hat Creek Diversion Canal.

Small service and access roads will drain to local watercourses by sidehill drains. Particular care will be taken to limit erosion and scour by the use of stable drains and by early re-planting of disturbed areas.

6.3.2.10 Sewage:

Sanitary effluent from the Mine Services Area will be biologically treated and directed to the Zero Discharge System where it will be re-cycled to dust-control use in the mine. Provision has been made for treating up to 140 m³/d.

6.4 WASTEWATER DISPOSAL

6.4.1 Discharge Objective:

To protect the environment in compliance with applicable government regulations, the quality of water discharged from the Hat Creek Mine should be within the British Columbia Ministry of the Environment Pollution Control Board's 'Level "A" Effluent Discharge Guidelines for the Mining Industry'.

6.4.2 Projected Quality of Mine Drainage:

Chemical analyses of groundwater from surficial materials would seem to indicate that it is of very similar quality to that of Hat Creek during low flow periods. Hence drainage and seepage from surficials is considered suitable for direct discharge except for sediment control.

Based on present data, seepage and well-drainage from bedrock is expected to be unsuitable for direct discharge. Projections of water quality from various sources are given in Table 6-4.

1. Slide Area:

Drainage from the wells will have high suspended solids concentrations. As a consequence, surface water and drainage from the wells will require sedimentation if the bentonitic slide debris is disturbed.

2. Waste Dumps:

Runoff from waste is not expected due to the hummocky nature of the dumped waste surface. During the reclamation of waste dumps, non-sodic materials would be added to the dump surface; runoff from these areas would need to be treated for sediment prior to discharge.

Tests of leachate from waste materials has shown it to be of a quality unsuitable for discharge to surface waters.

3. Coal-Blending Stockpiles:

Leachate will be unsuitable for discharge due not only to high concentrations of chemical contaminants, but also to low pH. Runoff and leachate will be virtually inseparable due to the semi-pervious nature of the stockpiles.

4. Low-Grade Stockpiles:

Leachate will contain roughly the same level of contaminants as in the coal-blending stockpiles. Runoff will probably be unsuitable for direct discharge.

5. Disturbed Land:

Projections have been made on the basis of previous mining experience. Runoff from stripped or disturbed land will contain high concentrations of suspended sediment. Average sediment yield may increase by a factor of three. Experience in North Dakota has shown that, even after re-planting, erosion rates may remain high. Sedimentation lagoons should therefore be kept in service until sediment has fallen to acceptable concentrations.

6. Mine Services Area:

Washdown water may contain high concentrations of oil, grease, coal fines, and suspended sediment.

6.4.3 Proposed Treatment to Meet Discharge Objective:

6.4.3.1 Zero Discharge System:

6.4.3.1.1 General:

Seepage and leachate flows of quality unsuitable for discharge from, for example, the pit, waste dumps, coal stockpiles and sewage treatment plant, will be stored in a "Zero Discharge" lagoon system and evaporated in Summer-time by re-cycling the water for dust-control operations on coal stockpiles and pit roads. The surplus will be used for spray irrigation on the active surfaces of waste dumps. An annual water deficit will occur at the mine site ranging from 170 mm to 350 mm, according to elevation. To take advantage of this evaporative potential, storage is required to hold back winter leachate discharges. To this end, a large lagoon will be constructed at the bottom of Hat Creek Valley, which will store 99% of the annual leachate production. A smaller secondary lagoon at Medicine Creek will store the other 1%.

6.4.3.1.2 Inflow, Outflow, and Lagoon Capacity:

The selection of the required capacity depends on three factors: the acceptable risk of a leachate spill; the quantity and time distribution of annual inflow; and the quantity and time distribution of annual outflow. In this feasibility study, sufficient capacity has been allowed to cope with the maximum projected groundwater flow plus twice the projected mean inflow from surface runoff. In practical terms, the worst flood envisaged has a 3% chance of exceeding lagoon capacity during the lifetime of the mine. Flows from smaller, disturbed watersheds will probably vary over a greater range, and an annual probability factor of between one and two percent is likely to be representative of the risk.

Three additional safety factors should be considered:

1. The bulk of inflow is pumped from the lower pit under the control of operations staff. When excessive inflow is likely to occur, it may be possible to store leachate in sumps in the bottom of the pit until capacity is available in the lagoon;

2. The increasing volume of inflow over the mining period requires a system which grows. Provision can be made to bring forward planned increments to lagoon capacity when called for, or deferred should the reverse happen;
3. In the unlikely event of a spill, the flow would be discharged back to the mine, as in (1) above.

Taking all factors into account, the chances of a spill are almost negligible.

Hydrographs of projected inflows and outflows to and from the zero discharge lagoons have been prepared for Years 5, 15 and 25.

The following conclusions have been drawn:

Year 5: A total lagoon capacity of 200,000 m³ is required. In mean years, a water deficit for dust control of about 120,000 m³ will exist, which will require make-up water from sedimentation lagoons. In an extreme year, all inflow could be consumed by dust-control operations in one year;

Year 15: A total lagoon capacity of 360,000 m³ is required. In a mean year, inflow will exceed dust-control outflow requiring spray irrigation on a dump area of about 5-10 ha. In an extreme year, approximately 100 ha of spray irrigation would be required to empty the lagoon before the next season;

Year 35: A total lagoon capacity of 560,000 m³ is required. In a mean inflow year, 50-60 ha of spray irrigation will be required, and in an extreme year 200-210 ha.

Based on these data, the proposed scheme at Hat Creek is both feasible and manageable.

6.4.3.1.3 North Valley Lagoon

The North Valley Lagoon will cover an area of up to 9 ha and be constructed in the bottom of Hat Creek Valley near the confluence with Houth Creek. The proposed layout features zoned earthfill dams at each end of the lagoon which can be raised in three 5 m stages to elevation 845 m. A further 5 m increase in dam height to 850 m has been allowed for as an emergency measure.

Material for dam construction will come from the pit surficials and from the East and West sides of the valley. A buried-membrane lining consisting of two metres of till overlying a 0.8 mm thickness PVC sheet will be laid on the prepared pond bottom and a lining of 0.8 mm PVC, one metre of till and one metre of sand and gravel will be placed on the pond sides.

The pond inlet and outlet will be at the South end of the pond. The pond outlet will consist of a concrete tower which will house leachate recycling pumps of total capacity 175 l/s. The buried discharge pipeline will supply pond effluent to:

- Sprinkle monitors at the coal-blending stockpiles;
- Water tanker filling points on the North pit incline;
- A discharge point at the top of the low-grade stockpile;
- A discharge point near the South abutment of the Houth Meadows Waste Embankment to service the spray irrigation system required in the latter part of the project.

An emergency spillway of capacity equal to the 1,000-year return period flood will be located on the West abutment of the North Dam; overflow would be directed to the open pit.

6.4.3.1.4 Medicine Creek Valley Lagoon:

The required leachate storage capacity is estimated at 12,000 m³, which will be created in a small pond of 0.7 ha. This pond will be lined with one metre of till over a 0.8 mm PVC liner, and will allow for expansion above projected storage requirements.

Inflow to the pond will be from field drains at the embankment base, and outflow will be pumped away to be disposed of by spray evaporation on the active dump surface.

An emergency spillway and runoff diversion drains will also be provided.

6.4.3.1.5 Operation:

The Zero Discharge System will require minimum maintenance. Seasonal inspection of the pond lining should be done in late Autumn when the pond level is at its lowest. The selection and maintenance of pumps and piping systems requires care, due to the presence of sediment and potentially aggressive water.

In relation to the pond volume of between 200,000 and 600,000 m³, the annual sediment build-up in the large lagoon of between 65 to 250 t/a will be insignificant, and the sediment will build up in the pond for the life of the project.

Geotechnical studies have shown that even full saturation of the waste dump surface would not affect the stability of the planned 5% slope, though Golder recommends that the materials near the transfer conveyor should be kept dry in order to improve the stability of the bench on which it operates. In relation to the large storage capacity of the lagoon, spray irrigation at the low rate of 250 mm/a should permit sufficient flexibility to allow satisfactory operation. Measures will be taken to ensure that no conflict arises between spray irrigation and the spreading of waste.

When the active life of the mine comes to an end, the mean annual lagoon inflow will decrease from 470,000 m³ to 25,000 m³. The Medicine Creek system will remain in operation until such time as the seepage is considered fit for discharge. Sewage, after biological treatment, will also be dealt with within the Zero Discharge System, and ultimately used for dust control. In the North valley, natural evaporation from the leachate pond will dispose of the residual leachate from the Houth Meadows Dump and the low-grade coal storage area. A flow hydrograph for Year 35 for these systems is shown in Figure 6-5.

6.4.3.2 Sedimentation Lagoon System:

6.4.3.2.1 General:

This is required to reduce projected high sediment concentrations in runoff otherwise fit for discharge. This runoff comes from natural rangeland stripped of soil-cover during construction and operation, pit surficials, permanent stormwater drainage, and re-graded and reclaimed waste dumps.

Two sets of lagoons are required, as shown in Figure 6-4. The first will consist of three lagoons constructed before mining begins to the North of the pit; the second two-lagoon system will be constructed in Year 16 downstream of the Medicine Creek Waste Dump.

6.4.3.2.2 Design Criteria:

The sediment removal efficiency of the lagoon system takes into account the Level "A" discharge objectives of the Pollution Control Board.

During larger flood flows, the efficiency of sediment removal will decrease, but as the natural suspended sediment concentration in Hat Creek itself will rise (specially during freshet), the net effect on receiving water quality should be low.

6.4.3.2.3 Inflow:

An analysis of land use in relation to the size of watersheds has produced the following 10-year 24-hour volumes of runoff:

Year 5 and 15: 78,000 m³

Year 35 : 91,000 m³

Annual mean discharges for the lagoons are estimated to total 1,050,000 m³ in Year 5; 1,093,000 m³ in Year 15; and 1,181,000 m³ in Year 35. A breakdown of lagoon inflows for Year 35 is shown on Table 6-5.

6.4.3.2.4 Sediment Tests:

These were carried out by B.C. Research in 1978 and show that only runoff from glacial-fluvial sand and gravel may be expected to satisfy the guidelines without chemical treatment. Alum has been found to be effective as a coagulant where concentration of sediment exceeds

the guidelines. It should be noted that only sediment with a substantially higher settling velocity than the design value will be admitted to the lagoons, a measure arising out of the recognition that the use of chemical coagulants should be minimized in order to avoid observed increases in sulphate concentrations.

6.4.3.2.5 North Valley Sedimentation Lagoons:

The three-lagoon system to be constructed North of the pit will consist of a primary sedimentation and flow balancing lagoon of 1.5 ha and two secondary lagoons totalling 4.5 ha. Total storage volume will be 250,000 m³. The materials for the retaining dams and dykes will be excavated from deposits in the mine area. Test drilling reveals that conditions may be encountered during construction which require that a low permeability till lining be applied to the bottom of the lagoons.

Inflow to the primary pond will be via a stilling basin and inlet manifold, and outflow will be controlled by two decant towers. Inflow to the secondary lagoons will be via a pipe manifold and outflow via an overflow weir. When chemical treatment is required, chemicals will be added at two mixing points.

During high inflow, the two secondary lagoons will operate in parallel; under low inflow, in series. This is designed to improve treatment efficiency and reduce the use of chemical coagulants. An emergency spillway channel will pass flows in excess of outlet capacity.

6.4.3.2.6 Medicine Creek Sedimentation Lagoons:

Two lagoons totalling 1.8 ha will be constructed before stripping operations in Year 15. The system will consist of a small primary and a larger secondary lagoon.

6.4.3.2.7 Lagoon Discharge:

The mean discharge hydrographs for the sedimentation lagoons are shown in Figure 6-6. The flood discharge hydrograph following 10-year 24-hour rainstorm is shown in Figure 6-7.

The effect of lagoon discharges on water quality have been assessed for three cases:

Case 1: where, under dry weather condition, Hat Creek would be at its lowest and the main inflow would be from de-watering wells.

Conclusion:

Water discharged will meet Pollution Control Board's "A" guidelines except for a higher sulphate concentration. The total dissolved solids concentration of receiving water will increase by less than 2%.

Case 2: where, under Spring runoff conditions, the main inflow would be from surface water in the lower pit. Hat Creek flows would be high.

Conclusion:

The North lagoon effluent will be suitable for discharge; only the sulphate concentration would exceed level A discharge objectives. Discharges from the pit rim reservoir would meet level A objectives for all parameters except copper which would be less than level B. The total dissolved solids concentration in receiving water would rise by 2%.

Case 3: where, under Summer rainstorm conditions, a large amount of surface runoff may occur in proportion to the rest of Hat Creek Valley.

Conclusion:

These are essentially the same as in Case 2 above, except that the solids concentration in receiving waters would increase by less than 5%.

The greatest increase in sulphate concentration occurs in Case 1, but amounts to only 31 mg/L, increasing from 54 mg/L to 85 mg/L.

Present Canadian standards for drinking water define 500 mg/L as acceptable and 250 mg/L as desirable. The natural concentration of sulphate in Hat Creek near the mine site measures approximately 59 mg/L and 76 mg/L further downstream. Taking all this into account, the lagoon effluent may therefore be deemed acceptable by the regulatory authorities.

The final concentration of copper in the receiving water is well below the acceptable level of 1 mg/L of the Canadian Drinking Water Standards 1968.

6.4.3.2.8 Operation:

To achieve the required discharge water quality, the lagoon system will require careful operation, maintenance, and regular checks and inspections of all components.

The total storage capacity of 100,000 m³ in the North lagoons and 30,000 m³ in the Medicine Creek Lagoon is calculated to be greater than the expected lifetime yield of sedimentation of 10,000 m³ and 500 m³ respectively. No clean-out will therefore be necessary.

After the mine has closed, the lagoon system will remain in operation until land reclamation has reduced sediment concentration in runoff to acceptable levels. During this time, the stored water may be used for irrigation.

The Mine Drainage Section of this report is based upon the CMJV Mine Drainage Report, October 1979, and has not been adjusted to reflect changes in the 1979 Mining Plan. The economic and environmental effects of such adjustments would be insignificant.

TABLE 6-1

Projected Groundwater Yield From The Mine Development
Hat Creek Project Mining Feasibility Report 1979

| | YEAR 5 VOLUME $m^3 \times 10^3$ | YEAR 15 VOLUME $m^3 \times 10^3$ | YEAR 35 VOLUME $m^3 \times 10^3$ |
|----------------------------|---------------------------------------|--|--|
| <u>OPEN PIT</u> | | | |
| Peripheral Wells | 520 | 520 | 520 |
| Seepage: | | | |
| - Surficials | 90 | 120 | 120 |
| - Bedrock | <u>20</u> | <u>50</u> | <u>30</u> |
| Total | 630 | 690 | 670 |
| <u>HOUTH MEADOWS DUMP</u> | | | |
| Embankment Seepage | | | |
| - No. 1 | 9.5 | 11 | 11 |
| - No. 2 | 1.5 | 3 | 4 |
| - No. 3 | <u>0</u> | <u>2</u> | <u>5</u> |
| Subtotal | 11 | 16 | 20 |
| To Regional Groundwater | <u>0.3-3</u> | <u>1.5-15</u> | <u>6-32</u> |
| Total | 11-14 | 17-31 | 26-52 |
| <u>MEDICINE CREEK DUMP</u> | | | |
| Embankment Seepage | 0 | 4 | 12 |
| To Regional Groundwater | <u>0</u> | <u>0.3-3</u> | <u>1-6</u> |
| Total | 0 | 4-7 | 13-18 |

Source: Golder 1979 Refer Appendix 2

TABLE 6-2

Design Criteria For Planning Of Mine Drainage System
Hat Creek Project Mining Feasibility Report 1979

| Type of Drainage Element | Description | Design Flood | Probability of Exceedence in 35-Year/Mine Life |
|--|-------------------------------|----------------------|--|
| Major Creek Diversions | Hat Creek | 1,000 year* | 3% |
| | Finney Creek | 1,000 year* | 3% |
| | Houth Creek | 1,000 year | 3% |
| | Upper Medicine Creek | Probable Max. Flood* | --- |
| Perimeter Drains | Around Pit | 100 year | 30% |
| | Waste Dumps & Slide Area | | |
| Surface Water Drains within mine development | Permanent Major Drains | 100 year | 30% |
| | Temporary Minor Drains | 10 year | 97% |
| Leachate Collection Systems | Field Drains | Max. Seepage Rate | --- |
| Dewatering Wells | Collection Systems | Max. Pumping Rate | --- |
| Sedimentation Lagoons | Emergency Spillways | 1,000 year | 3% |
| | Treatment Capacity | 10 year | 97% |
| Leachate Storage Lagoons | Emergency Spillways | 1,000 year | 3% |
| | Storage and Disposal Capacity | 2x Mean Annual Flow | --- |

* Refer BCH HEDD 1978 and Monenco 1977 for Design Criteria

TABLE 6-3

Design Flows for Preliminary Planning of the Mine Drainage System
Hat Creek Project Mining Feasibility Report 1979

| Code (as on Schematic) | Description | Watershed Area km ² | Flow Frequency | Flow Type | Estimated Flow m ³ /sec | Estimated Volume m ³ x 1000 | Data Sources | Remarks |
|--|---------------------------------|-----------------------------------|-------------------|--------------|--|--|-----------------|---------------------------------------|
| HAT CREEK | | | | | | | | |
| Q1 | Hat Creek u/s of mine | 248 | A | M | 0.63 | - | 1 | - |
| Q2 | Hat Creek d/s Medicine Creek | 308 | A | M | 0.67 | - | 1 | 52km ² to PP Res |
| Q3 | Hat Creek d/s of mine | 383 | A | M | 0.72 | - | 1 | - |
| - | Diversion Canal Capacity | - | 1000F | P | 27 | - | 3 | Under emergency |
| DIVERSION DRAINS | | | | | | | | |
| D1 | Upper SW pit | 2.0 | 100R | P | 0.75 | - | 1 | - |
| D2 | South Slide runoff | 3.7 | 100R | P | 1 | - | 1 | - |
| D3 | South Slide Diversion | 1.3 | 100R | P | 1 | - | 1 | - |
| D4 | Finney Ck Canal | 21 | 1000F | P | 3.50 | - | 1 | - |
| D5 | Ambusten + SE Watershed | 35 | 1000F | P | 7 | - | 1 | - |
| D6 | Pit Rim Pump | 4.4 | - | P | 0.12 | - | 3 | Pump capacity |
| D7 | Medicine Ck Runoff Canal | - | - | - | - | - | - | - |
| D8 | Medicine Ck Runoff Canal | - | - | - | - | - | - | - |
| D9 | East Watershed | 2 | 100R | P | 1.2 | - | 1 | - |
| D10 | North Slide runoff | 1.2 | 100R | P | 0.6 | - | 1 | - |
| D11 | North Slide Diversion | 4.5 | 100R | P | 1.75 | - | 1 | - |
| D12 | West Perimeter Diversion | 25 | 1000F | P | 4.2 | - | 1 | - |
| D13 | North Perimeter Diversion | 1 | 100R | P | 1 | - | 1 | - |
| P1 | Lower SW Diversion | 1.7 | 100R | P | 0.7 | - | 1 | - |
| P2 | SE Diversion | 0.5 | 100R | P | 0.5 | - | 1 | - |
| P3 | Watershed below Canal | 3 | 100R | P | 1.5 | - | 1 | - |
| L1 | Canal Leakage | - | DY | M | 0.01-0.025 | - | 3 | - |
| MINE DRAINAGE COLLECTION SYSTEM | | | | | | | | |
| | | | | | | <u>24hr Volume</u> | | |
| S1 | Houth Meadows Dump | - | 10R | P | - | 15 | 1 | Project at max size |
| S2 | Disturbed slide area runoff | 100 | 10R | P | - | 6 | 1 | " |
| S3 | Slide dewatering wells | - | DY | P | - | 0.044 | 2 | " |
| S4 | Runoff from Pit Surficials | 335 | 10R | P | - | 48 | 1 | " |
| S5 | Groundwater from pit Surficials | - | DY | P | - | 2 | 2 | " |
| S6 | North Valley Services area | 200 | 10R | P | - | 20 | 1 | " |
| S7 | Washdown water | - | DY | M | - | 0.090 | 1 | " |
| S8 | Medicine Creek Dump | - | 10R | P | - | 13 | 1 | " |
| DISCHARGE OF TREATED DRAINAGE | | | | | | | | |
| W1 | North Valley Sed. Lagoons | - | 10R | P | 0.8 | 56 | 1 | From Hydrograph |
| W2 | Medicine Creek Sed. Lagoons | - | 10R | P | 0.2 | 13 | 1 | " " |
| ZERO DISCHARGE SYSTEM | | | | | | | | |
| | | | | | | <u>Est. Annual Volume</u> | | |
| Z1 | Sanitary Effluent | - | DY | M | 0.0016 | 51 | 1 | 700 man shifts/day |
| Z2 | Coal Blending Leachate | 0.22 | A | M | - | 20 | 1 | Project at max size |
| Z3 | Low-Grade Coal Leachate | 0.33 | A | M | - | 16 | 1 | " |
| Z4 | Houth Dump Leachate | - | A | M | - | 11 | 2 | " |
| Z5 | Pit Coal & Rock Leachate | - | A | M | - | 332 | 1 | " |
| Z6 | Dust Control consumption | - | A | M | - | 319 | 1 | " |
| Z7 | Evaporative Disposal | - | A | M | - | 129 | 1 | " |
| Z8 | Medicine Dump Leachate | - | A | M | - | 12 | 2 | " |
| WATER SUPPLY SYSTEM | | | | | | | | |
| H1 | Mine Services Area | - | DY | M | 0.0041 | 101 | 1 | 700 shifts/day + garden + washroom |
| H2 | Reveg Nursery | - | A | M | - | 75 | 1 | 10ha |

Key to Symbols in Table:

| | | | |
|-------|---|---------------------------------|---------------------|
| 100R | - | 100-year Av recurrence interval | rainstorm flood |
| 1000F | - | 1000-year Av | rain-snowmelt flood |
| 10R | - | 10-year Av | rainstorm flood |
| DY | - | | Daily |
| A | - | | Annual |
| P | - | | Peak Discharge |
| M | - | | Mean Discharge |

Sources of Data:

| | |
|---|------------------------|
| 1 | CMJV Estimate |
| 2 | Golder Assoc. 1978, 79 |
| 3 | BCH HEDD, 1978 |

NOTE:

These data are based on Preliminary Mine Planning Data, Hydrological and Hydrogeological Studies. Surface water flows from small watersheds and seepage flows are estimates based on several arbitrary assumptions as to runoff infiltration factors and hydraulic conductivities. They therefore should be upgraded when further site-specific data becomes available. Where a range of flow is shown, this identifies the variability of flow in terms of the assumptions made. Areas used correspond to the estimated maximum effective area of natural watersheds, disturbed areas, or mine facilities to be drained.

TABLE 6-4

Projections of Water Quality of Mine Drainage
Hat Creek Mining Feasibility Study 1979

| Parameter (mg/l) | NATURAL SURFACE WATER | | | | MINE DRAINAGE | | | | | DISCHARGE GUIDELINES | | | |
|--------------------------------------|-----------------------|---------------------------|----------------|----------------|-------------------------------------|-----------------|------------------------------|------------------|-----------------------------------|-------------------------------------|-----------------------------|-------------------------------------|-----------------------------------|
| | Hat(1) Creek | Medicine Creek Area | Finney Lake | Aleece Lake | Medicine Creek Dump Runoff | Ash Leachate | Mine Waste(2) Leachate | Coal Leachate | Low- Grade Coal Leachate | Slide Debris Ground- water | Pit- water(2) Bedrock | Pit- water(2) Sur- ficials | PCB Level A Objec- tives |
| pH (units) | 8.4 | 8.3 | 8.2 | 7.6 | 8.0-8.5 | 8.0-9.0 | 8.1 | 5.0* | 4.6* | 8.0 | 7.8 | 7.9 | 6.5-8.5 |
| Filterable Residue | 336 | 275 | 17.9 | N.A. | 1900- | 4800- | 1125 | 8400* | 5400* | 1070 | 1950 | 350 | <2500 |
| Non-Filterable Residue | 8- | 0-110 | N.A. | N.A. | >50* | N.A. | N.A. | N.D. | N.D. | N.D. | N.D. | N.D. | <50 |
| BOD ₅ | <1 | N.A. | N.A. | N.A. | <115-150 | <35-195 | 137 | N.D. | N.D. | N.A. | N.D. | N.D. | N.D. |
| TOC | 8 | 19 | 18 | N.A. | N.A. | N.A. | N.A. | N.A. | N.D. | 50 | 50 | 21 | N.D. |
| Alkalinity | 212 | 221 | 123 | 217 | 332-360 | 1120- | 123 | <27 | <0.5 | 570 | 1185 | 310 | N.D. |
| Chloride | 1.2 | 0.4 | 0.5 | <0.5 | 58-61 | 175-190 | 27 | 14 | 0.88 | 28 | 42 | 4 | N.D. |
| Fluoride | 0.14 | 0.12 | 0.22 | N.A. | 0.7-1.1 | 3.3-4.9* | 0.06 | 0.1 | N.D. | 0.16 | 0.2 | 0.2 | 2.5 |
| Nitrate (as N)*** | <0.06 | 0.04 | <0.02 | N.A. | 3.5-4.2 | 2.4-3.3 | 4.4 | N.D. | N.D. | <0.14 | <0.06 | <0.2 | 10 |
| Kjeldahl Nitrogen (as N) | 0.19 | 0.26 | 0.83 | N.A. | N.A. | N.A. | N.A. | N.A. | N.A. | <11 | 14 | <0.2 | N.D. |
| Ortho Phosphate (as P) | 0.038 | 0.01 | 0.025 | N.A. | 0.27- | 0.14- | 0.3 | 0.01 | N.D. | <0.03 | <0.03 | <0.03 | 2 |
| Sulfate | 50 | 20 | 5 | 52* | 330-350* | 1500- | 21 | 3700* | 3800* | 380* | <321* | 270* | 50(3) |
| Arsenic | <0.005 | <0.005 | <0.005 | N.A. | <0.18- | <0.6- | 0.07* | <0.005 | <0.005 | <0.005 | 0.006 | <0.005 | 0.05 |
| Boron | <0.01 | <0.1 | <0.1 | N.A. | <0.7-0.8 | <3.0-3.6 | 0.04 | 0.31 | 0.7 | <0.21 | 0.31 | <0.1 | N.D. |
| Cadmium | <0.005 | <0.005 | <0.005 | N.A. | 0.022* | <0.1 | <0.002 | N.D. | N.D. | <0.005 | <0.005 | <0.005 | 0.005 |
| Calcium (as CaCO ₃) | 145 | 130 | 60 | 85 | 260-275 | 1050- | 48 | 1900 | 1075 | 208 | 180 | 200 | N.D. |
| Chromium | <0.01 | <0.01 | <0.01 | N.A. | <0.13- | <0.12- | 0.13* | <0.01 | <0.01 | <0.01 | <0.01 | <0.01 | 0.05 |
| Copper | <0.005 | <0.005 | <0.005 | N.A. | <1.2- | <0.23- | 1.5* | 0.04 | <0.007 | <0.008 | <0.008 | <0.005 | 0.05 |
| Iron | <0.018 | <0.02 | <0.04 | <0.05 | <1.4- | 1.95- | 1.25* | 0.26 | <0.01 | <0.06 | <0.075 | <0.031 | 0.3 |
| Lead | <0.01 | <0.01 | <0.01 | N.A. | <0.026 | <0.05 | 0.02 | N.D. | N.D. | <0.03 | <0.013 | <0.01 | 0.05 |
| Magnesium (as CaCO ₃) | 74 | 85 | 33 | 100 | 72-75 | 220-230 | 33 | 2240* | 1680* | 118 | 124 | 116 | 652(as CaCO ₃) |
| Mercury | <0.00038 | <0.0005 | <0.00033 | N.A. | <0.0015- | <0.0013- | 0.0015* | <0.0003 | <0.0003 | <0.0003 | <0.0003 | <0.0003 | 0.001 |
| Sodium | 20 | 11 | 15 | 38 | 115-120 | 325-335 | 63 | 190 | 150 | 230 | 412 | 93 | N.D. |
| Vanadium | <0.005 | <0.005 | <0.005 | N.A. | <0.05- | <0.18- | 0.01 | <0.04 | 0.006 | <0.006 | <0.007 | <0.005 | N.D. |
| Zinc | 0.008 | 0.009 | <0.006 | N.A. | 0.06 | 0.22 | 0.15 | 0.11 | 0.18 | <0.36 | 0.52* | <0.03 | 0.5 |

SOURCE: Beak 1978, 1979 NOTE: (1) Mean of measurements taken Sept. 1976-1977 during a low flow year.
(2) Surface runoff has been projected to be of this quality (Beak 1979).
(3) Subject to review.

* indicates parameter is in excess of PCB Level A Guideline

TABLE 6-5

Estimated Sedimentation Lagoon Inflow - Year 35
 Hat Creek Project Mining Feasibility Report - 1979

| Source | Area (ha) | CN | Qm (m ³ x10 ³) | Q10 (m ³ x10 ³) | Q35 (m ³ x10 ³) | Q100 (m ³ x10 ³) |
|---|--------------|----|--|---|---|--|
| <u>NORTH VALLEY LAGOONS</u> | | | | | | |
| 1. Open Pit Mine | | | | | | |
| Runoff above EL 900 | 250 | 90 | 200 | 38 | 65 | 100 |
| Runoff below EL 900 | 85 | 90 | 68 | (38)10* | (22)10* | (17)10* |
| Dewatering flow | | | 656** | 2 | 2 | 2 |
| 2. North Valley | | | | | | |
| Service areas, roads, and open space | 200 | 85 | 100 | 20 | 38 | 64 |
| 3. Slide Area | | | | | | |
| Disturbed land | 100 | 80 | 50 | 6 | 13 | 24 |
| 4. Houth Meadows Waste Dump | | | | | | |
| Stripped land | - | - | - | - | - | - |
| Levelled waste | 24 | 90 | 12 | 4 | 6 | 10 |
| Reclaimed land | 190 | 80 | 95 | 11 | 25 | 46 |
| Total North Valley Lagoons | 849 | - | 1181 | 91 | 159 | 256 |
| <u>MEDICINE CREEK LAGOONS</u> | | | | | | |
| 5. Medicine Creek Dump | | | | | | |
| Stripped land | - | - | - | - | - | - |
| Levelled waste | 24 | 90 | 12 | 4 | 6 | 10 |
| Reclaimed land | 148 | 80 | 74 | 9 | 19 | 36 |
| Total Medicine Creek Lagoons | 172 | - | 86 | 13 | 25 | 46 |

Note:

- CN = Curve number for soil cover complex refer Fig.
- Qm = Mean annual volume of runoff.
- Q10 = 10-year recurrence interval 24-hour runoff volume.
- Q35 = 35-year recurrence interval 24-hour runoff volume.
- Q100 = 100-year recurrence interval 24-hour runoff volume.

It is assumed that maximum 24-hour inflows will occur during summer rainstorms.
 Curve numbers for soil cover complexes have been estimated from literature (USSCS 1964, 1975).

- * Contribution to pond inflow limited by pump capacity.
- ** Includes 16,000 m³ from slide area.

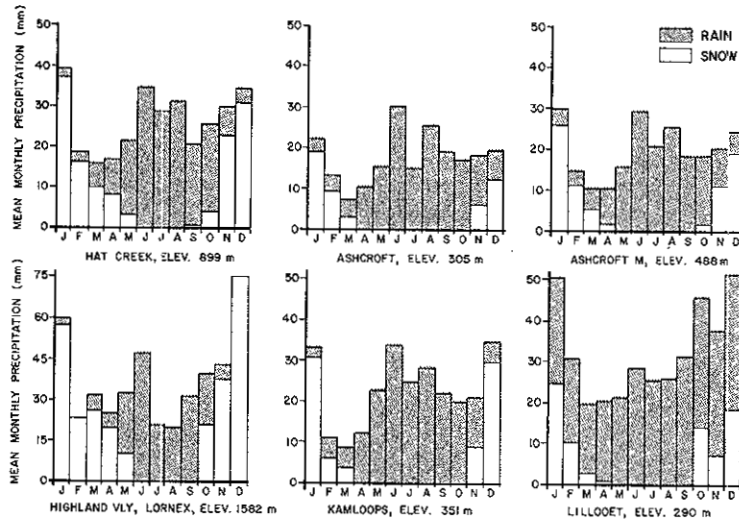
TABLE 6-6

Projected Quality of Lagoon Discharge and Hat Creek - Case III*
 Hat Creek Project Mining Feasibility Report 1979

| Parameter (mg/l) | Projected Effluent North Lagoon | Projected Pit Rim Dam Discharge | Existing Hat Creek | Projected Hat Creek After Mixing |
|--|--|--|-----------------------|---|
| pH (Units) | 8.4 | 8.3 | 8.4 | 8.4 |
| Temperature °C | N.D. | N.D. | N.D. | N.D. |
| Filterable Residue | 376 | 450 | 342 | 435 |
| Non-Filterable Residue | <50 | <50 | 95 | 82 |
| TOC | 11 | 20 | 9 | 12 |
| Total Hardness (as CaCO ₃) | 220 | 196 | 224 | 227 |
| Alkalinity (as CaCO ₃) | 223 | 200 | 226 | 230 |
| Chloride | 2.3 | 5.0 | 1.1 | 3.6 |
| Fluoride | 0.16 | 0.13 | 0.16 | 0.19 |
| Total Nitrogen (N) | <0.43 | 0.60 | 0.24 | <0.43 |
| Phosphorus (P) | <0.05 | <0.06 | 0.043 | <0.05 |
| Sulfate | 57 | 35 | 54 | 63 |
| Arsenic | <0.008 | <0.019 | <0.005 | <0.023 |
| Boron | <0.1 | <0.09 | <0.1 | <0.13 |
| Cadmium | <0.005 | <0.005 | <0.005 | <0.006 |
| Calcium (as CaCO ₃) | 140 | 122 | 143 | 146 |
| Chromium | <0.015 | <0.03 | <0.01 | <0.016 |
| Copper | <0.07 | <0.26 | <0.005 | <0.066 |
| Iron | <0.08 | <0.23 | <0.026 | <0.09 |
| Lead | <0.01 | <0.012 | <0.01 | <0.01 |
| Magnesium (as CaCO ₃) | 76 | 73 | 77 | 77 |
| Mercury | <0.0004 | <0.0006 | <0.0004 | <0.0007 |
| Sodium | 24 | 24 | 20 | 24 |
| Vanadium | <0.005 | <0.006 | <0.005 | <0.007 |
| Zinc | <0.014 | <0.03 | <0.007 | <0.035 |

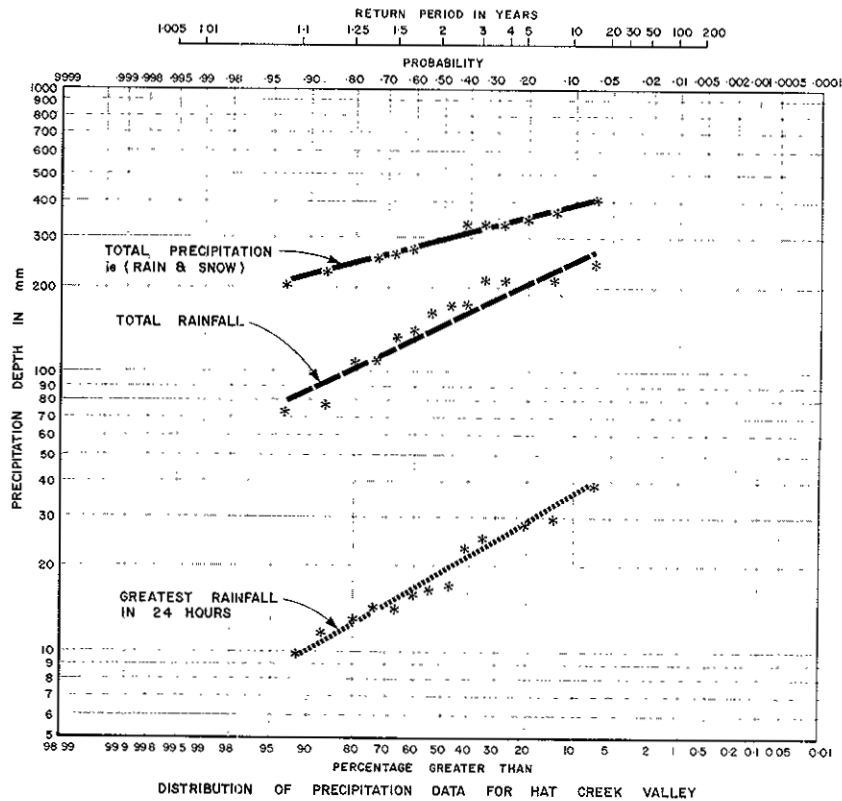
* Summer Rainstorm Condition (Year 35) Discharges to Hat Creek via sedimentation ponds include surface runoff caused by a 10-year 24-hour rainfall, dewatering flows from pit surficials and from the slide area. Hat Creek discharge was assumed to be 1.68 m³/sec. Surface runoff and dewatering rates are from CMJV estimates. Flow attenuation has been assumed to occur in the lagoons.

(Source: Beak 1979)



SEASONAL DISTRIBUTION OF MEAN MONTHLY PRECIPITATION IN THE HAT CREEK REGION

from Atmospheric Environment Service Canadian Normals, 1973



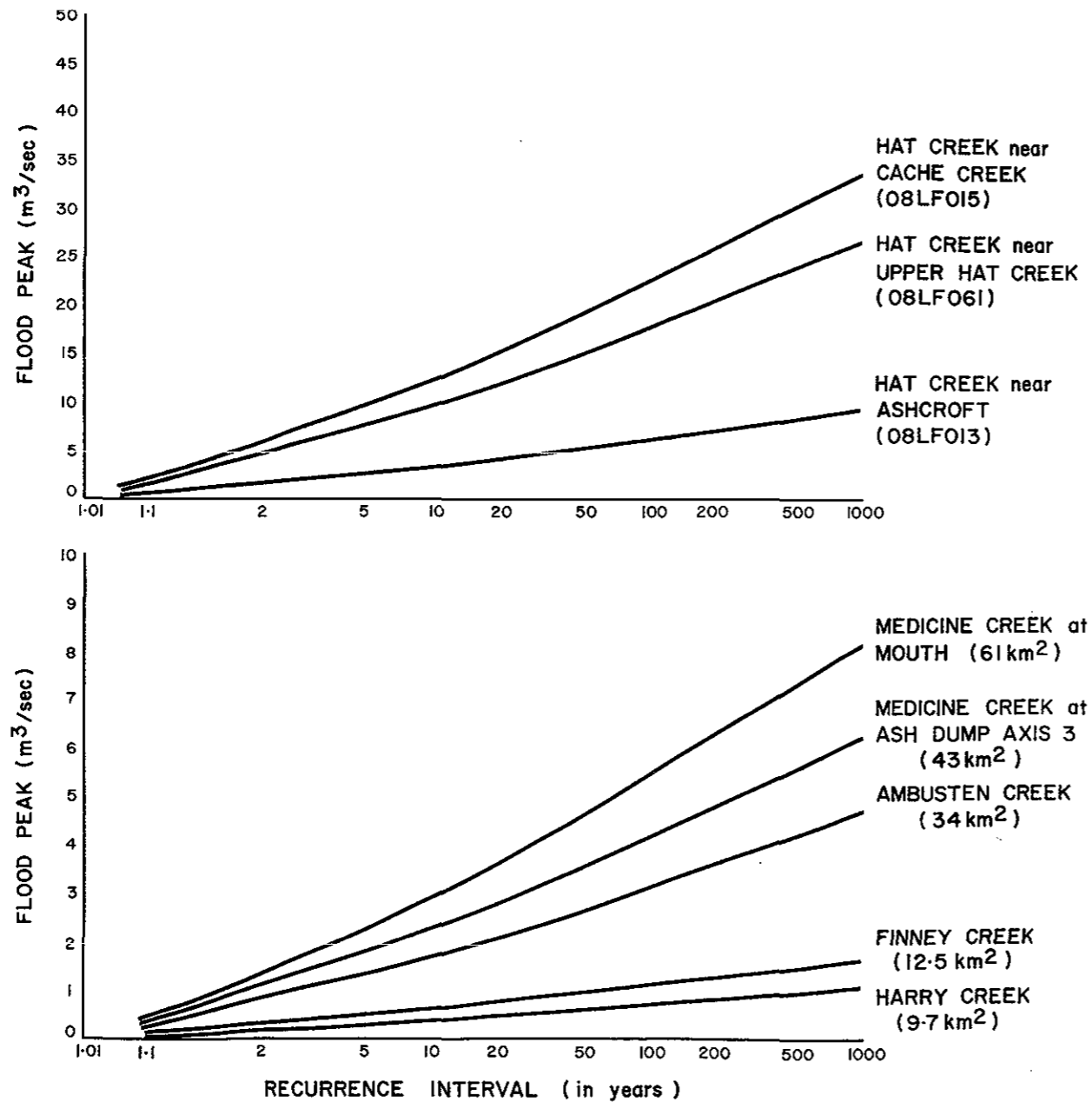
from Atmospheric Environment Service, Climatological Station Data

Source: Beak Hydrology Inventory Study, Draft March 1978

FIGURE 6-1
BRITISH COLUMBIA HYDRO & POWER AUTHORITY
HAT CREEK PROJECT
MINING FEASIBILITY REPORT
PRECIPITATION DATA



FLOOD FREQUENCY CURVES DERIVED FROM REGIONAL DATA



NOTE:
CURVES SHOWN ARE FOR ANNUAL SNOWMELT FLOODS

Source: B.C. Hydro H.E.D.D. Report 913, 1978.

MONTHLY FLOW IN HAT CREEK JUST ABOVE THE MINE SITE

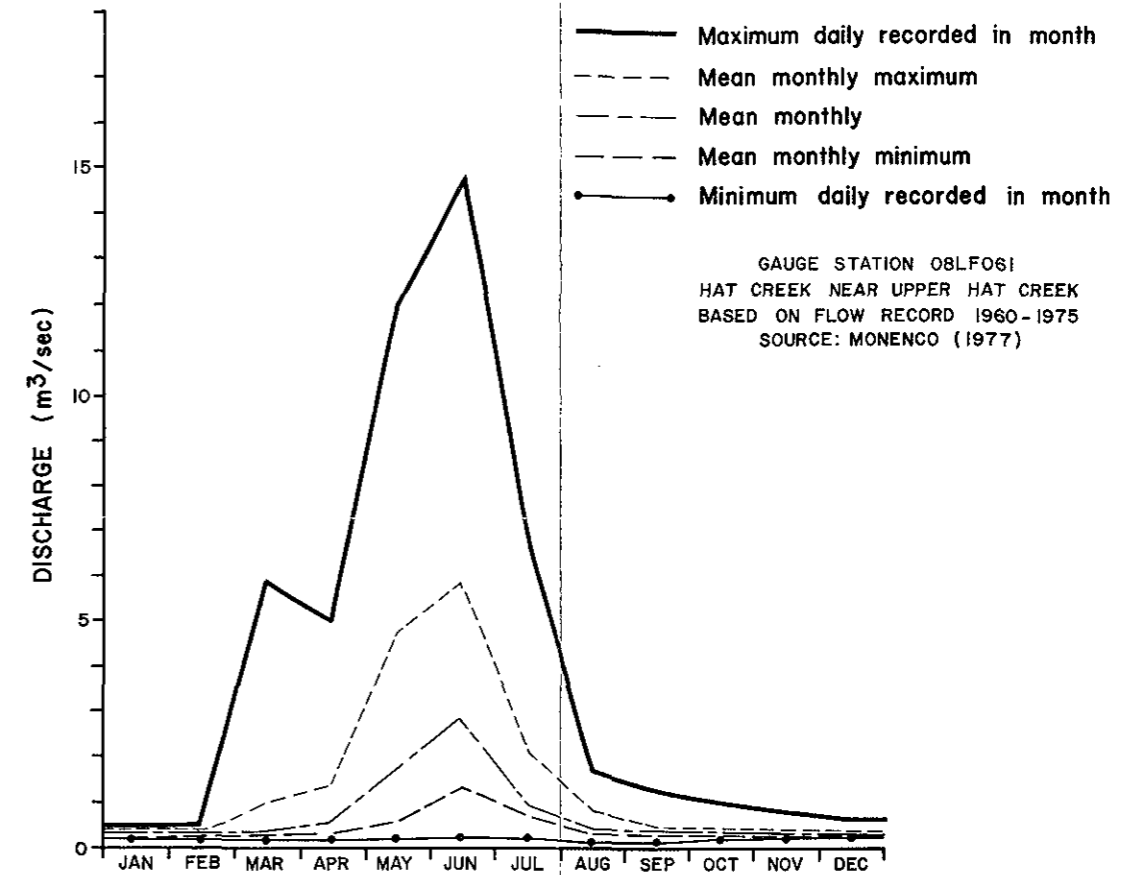
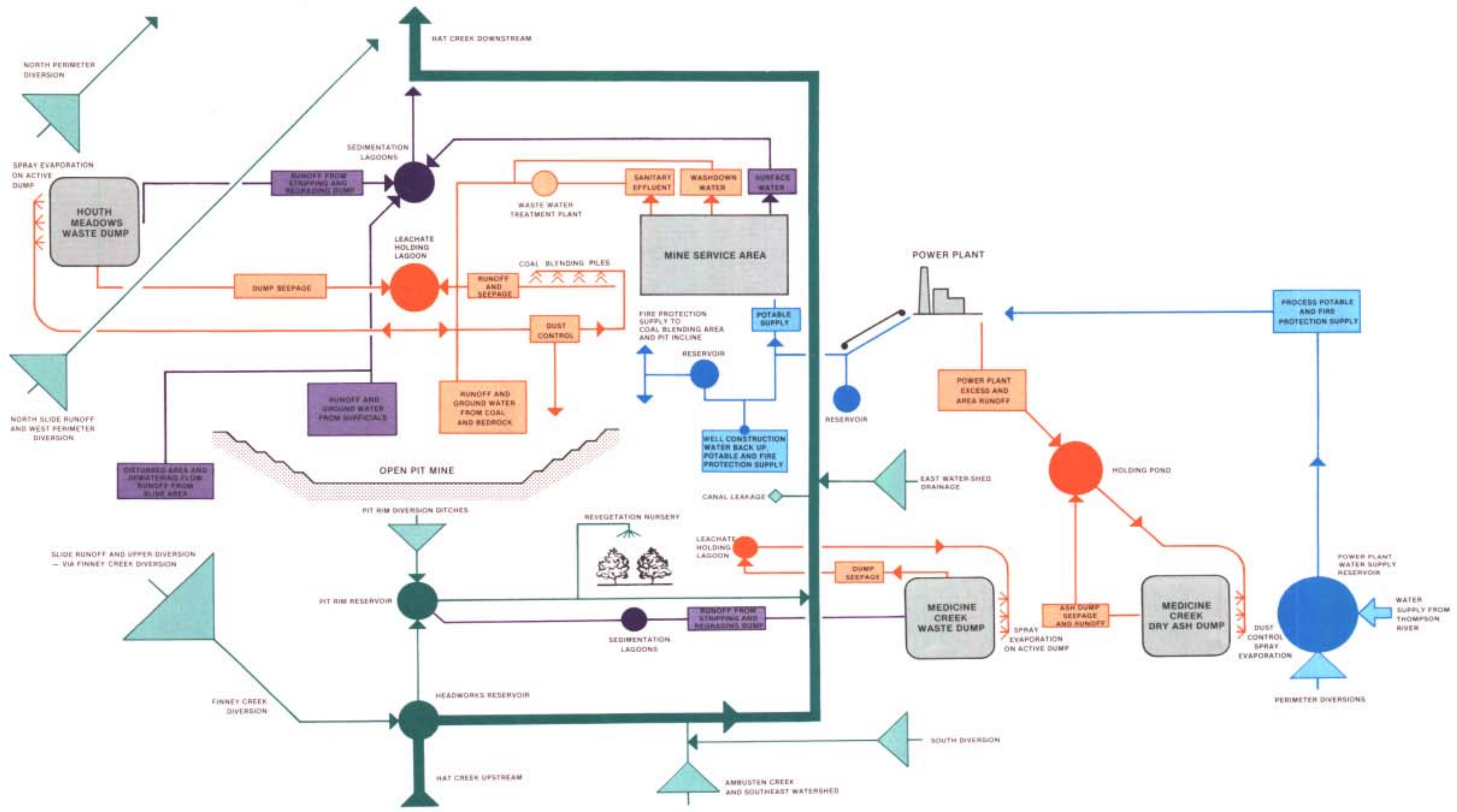


FIGURE 6-2

BRITISH COLUMBIA HYDRO & POWER AUTHORITY
HAT CREEK PROJECT
MINING FEASIBILITY REPORT
STREAMFLOW DATA

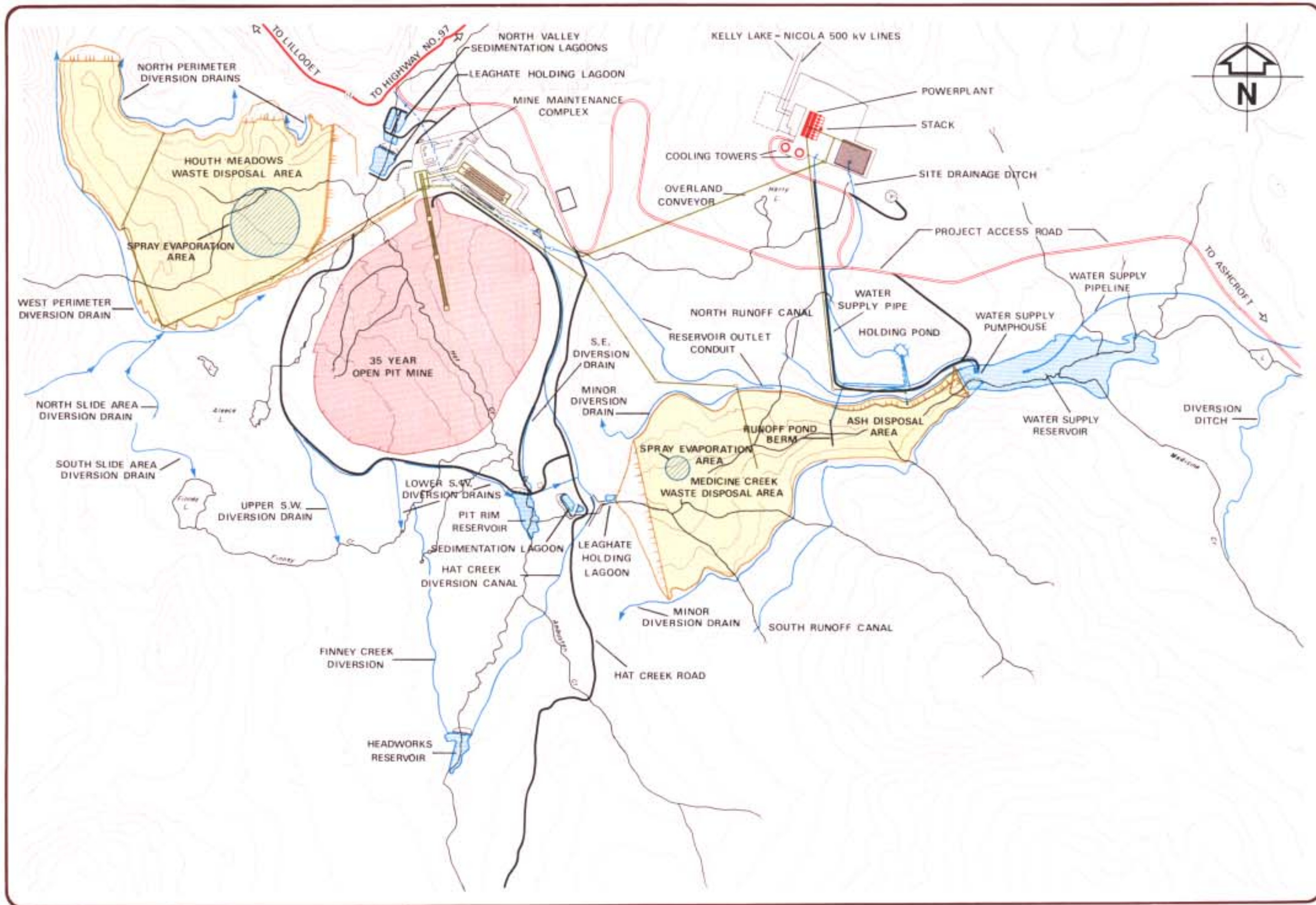


LEGEND

- PROCESS POTABLE AND FIRE PROTECTION SUPPLY
- HAT CREEK AND NON-CONTAMINATED WATER
- WATER FROM DISTURBED AREAS REQUIRING TREATMENT
- WATER UNSUITABLE FOR DISCHARGE

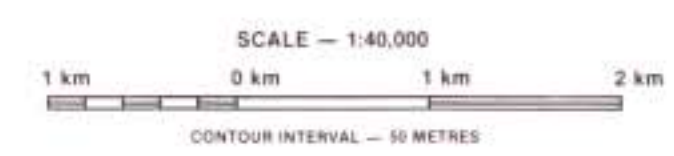
HAT CREEK PROJECT
FIGURE 6-3
PROJECT DRAINAGE AND
WATER SUPPLY FLOW DIAGRAM

SOURCE: Columbia - Missouri Joint Venture (B)



LEGEND

- RESERVOIRS AND LAGOONS
- DRAINAGE AND DIVERSION

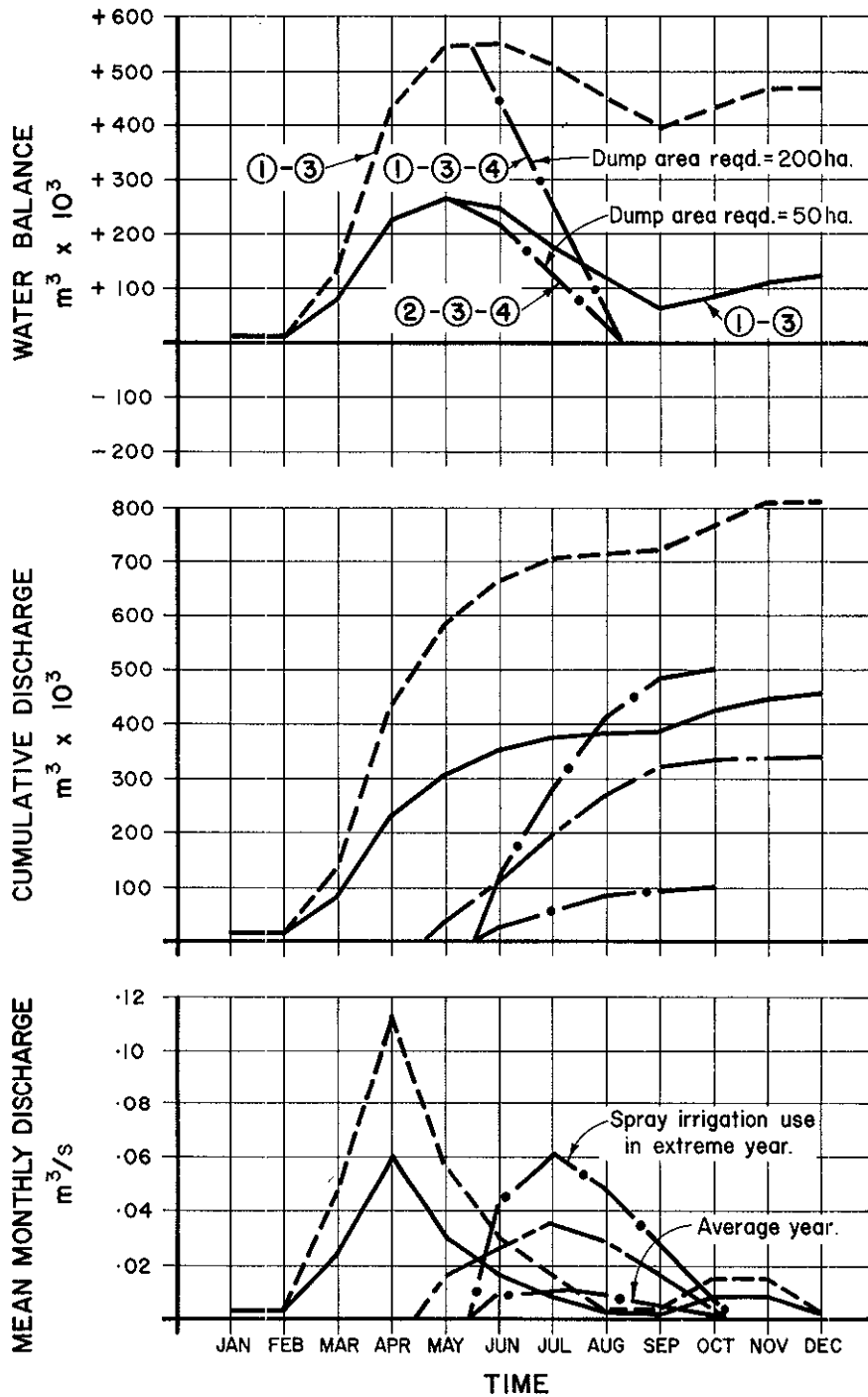


HAT CREEK PROJECT

FIGURE 6-4

PROJECT DRAINAGE AND DIVERSION SYSTEM

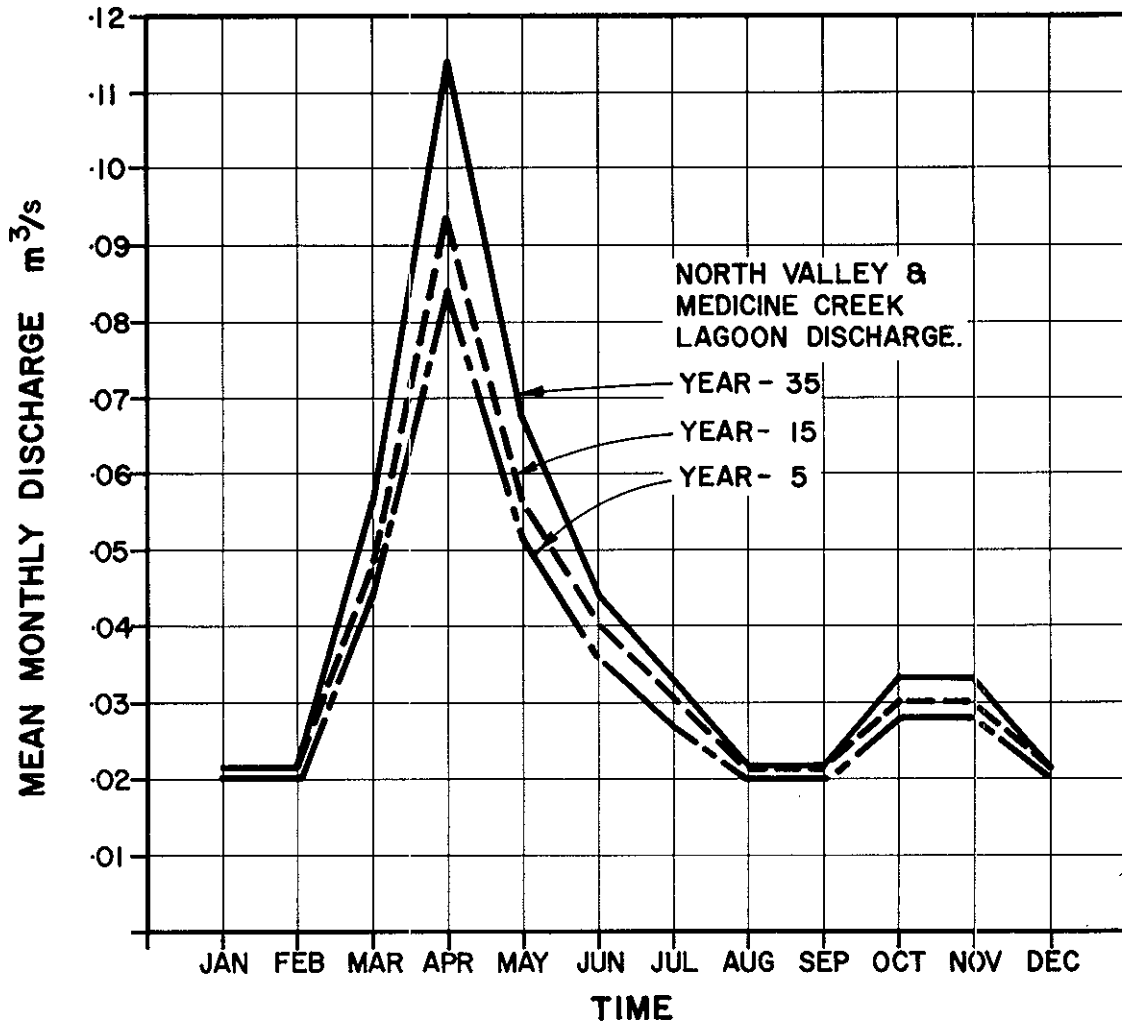
SOURCE: COMINCO — MORENCO JOINT VENTURE (R)



LEGEND

- ① ----- EXTREME INFLOW
- ② ————— MEAN INFLOW
- ③ - - - - - DUST CONTROL OUTFLOW
- ④ — • — SPRAY IRRIGATION OUTFLOW

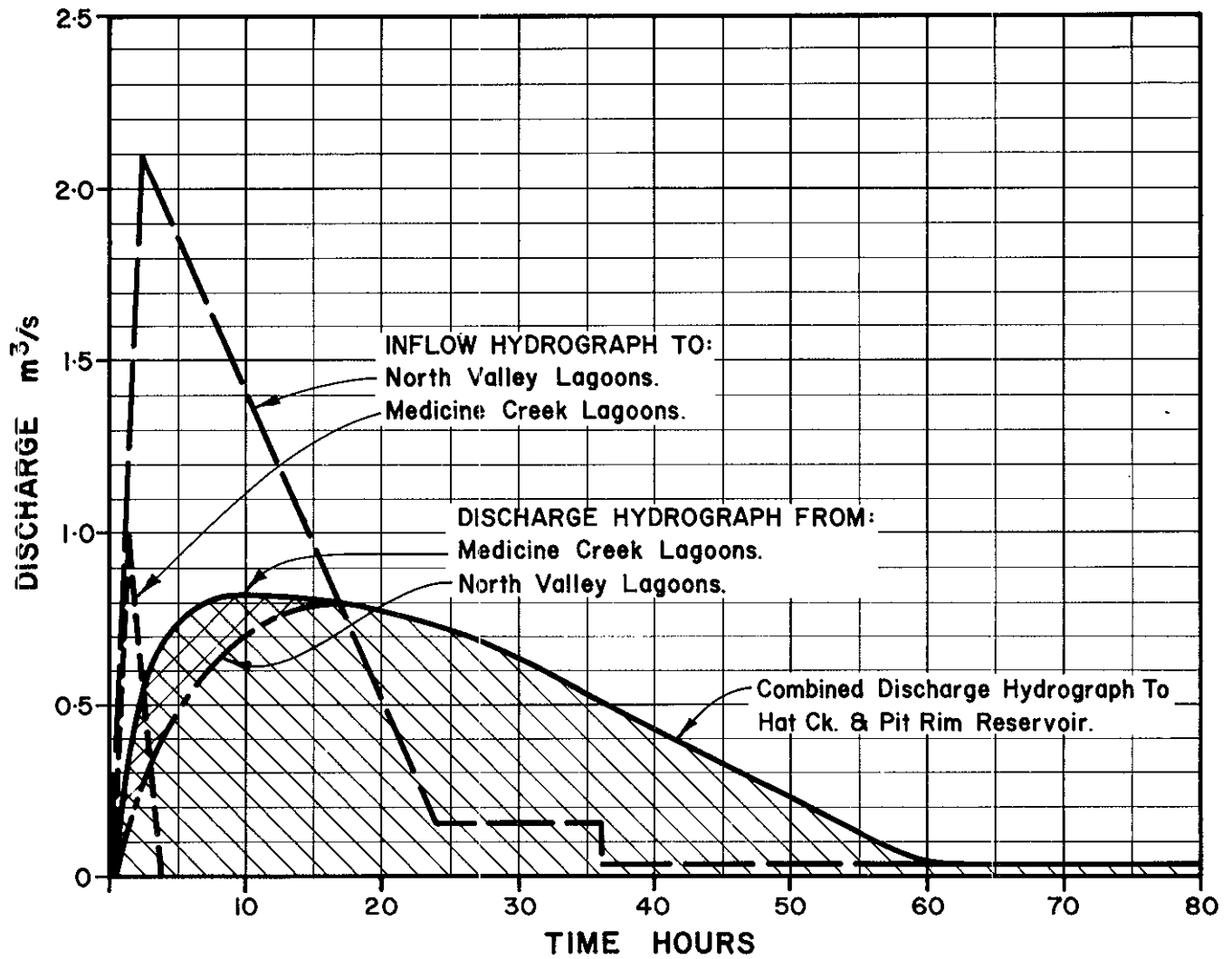
FIGURE 6 - 5
 BRITISH COLUMBIA HYDRO & POWER AUTHORITY
 HAT CREEK PROJECT
 MINING FEASIBILITY REPORT
 ZERO DISCHARGE SYSTEM
 HYDROGRAPHS-YEAR 35



NOTE

Pond loss to seepage and evaporation plus dust control use early in mine development may reduce summer flows by $.010 - .025 \text{ m}^3/\text{s}$

FIGURE 6 - 6
BRITISH COLUMBIA HYDRO AND POWER AUTHORITY
HAT CREEK PROJECT
MINING FEASIBILITY REPORT
SEDIMENTATION LAGOONS
ESTIMATED MEAN DISCHARGE
HYDROGRAPHS



NOTE

The lagoons are sized on the basis of these hydrographs. Emergency Spillways will be sized for the 1:1000yr. return period flood.

FIGURE 6 - 7
BRITISH COLUMBIA HYDRO AND POWER AUTHORITY
HAT CREEK PROJECT
MINING FEASIBILITY REPORT
SEDIMENTATION LAGOONS
10 YEAR 24 HOUR
FLOOD DISCHARGE HYDROGRAPH

| 7 | <u>FUEL QUALITY</u> | <u>Page</u> |
|-----|--|-------------|
| 7.1 | Introduction | 1 |
| 7.2 | Hat Creek Coal | 2 |
| 7.3 | Coal Beneficiation | 4 |
| | 7.3.1 Testing Program | 4 |
| | 7.3.2 Conclusions Drawn from Test Results | 5 |
| | 7.3.3 Alternative Beneficiation Processes Considered | 6 |
| | 7.3.4 Tailings Disposal | 7 |
| | 7.3.5 Conclusions | 8 |
| 7.4 | Boiler Fuel Specification Development | 9 |
| | 7.4.1 Introduction | 9 |
| | 7.4.2 Data Assessment | 10 |
| | 7.4.3 Fuel Assessment | 11 |
| | 7.4.3.1 Testing Program | 11 |
| | 7.4.3.2 Comparison with Other Plants | 13 |
| | 7.4.4 The Boiler Fuel Specification | 14 |
| 7.5 | Low-grade Coal | 15 |
| 7.6 | Fuel Quality Control | 17 |
| | 7.6.1 Introduction | 17 |
| | 7.6.2 Control Program | 17 |
| | 7.6.3 Special Operations | 19 |

| <u>No.</u> | <u>LIST OF TABLES</u> | <u>Page</u> |
|------------|---|-------------|
| 7-1 | Classification of Hat Creek Coal | 20 |
| 7-2 | Comparison of Hat Creek and San Miguel Fuel Characteristics | 21 |
| 7-3 | Boiler Fuel Specification | 22 |
| 7-4 | Size Consist - Powerplant Feed | 24 |

SECTION 7

FUEL QUALITY

7.1 INTRODUCTION

The quality of the coal to be supplied as boiler fuel has a major impact on the design, economics, and the environment of both the mine and the powerplant. Because of the wide range of variability of the coal in the Hat Creek No. 1 Deposit, it is possible to produce a number of fuels of different quality. As a basis for the selection of the project performance fuel, the following objectives were established:

- (1) The performance fuel must be within the design limitations for conventional North American boilers and pulverizers;
- (2) A consistent quality of coal within specified tolerance limits must be supplied to the powerplant;
- (3) Utilization of the coal resource should be maximized;
- (4) Adverse environmental impacts should be minimized;
- (5) The energy cost should be minimized. This requires a careful balancing of capital and operating cost factors between the mine and the powerplant.

To meet these objectives, a mining method has been developed that will economically produce performance fuel for the boilers, while providing for a high level of resource utilization and minimizing environmental risk.

A sequence of mining plans and production schedules developed for the anticipated life of the powerplant demonstrate that fuel of a consistent quality - 18.0 MJ/kg - can be produced by selective mining within a tolerance of 1.0 MJ/kg. To smooth out short-term fluctuations in the fuel quality, a comprehensive blending stockpile and reclaim facility is planned. The mining plan is flexible; it will always permit access to higher quality, low-sulphur coal when necessary to cope with predicted short-term sulphur dioxide excursions beyond regulated ambient levels.

The beneficiation of coal by washing was studied at length and rejected on technical, economic, resource utilization, and environmental grounds.

The quality of the coal in the Hat Creek coal deposits varies over an unusually wide range. The reasons for this are presented in Section 5.3.8.1, which discusses how the coal was deposited and how the coal formation grades from good coal through low-grade coal to clay.

It is difficult to present a clear cut classification system that consistently and accurately describes the different grades of coal, except on the extremes of the range. The good coal is shiny, black, thinly bedded, hard, and breaks with a glassy conchoidal fracture. This coal is typical of the D-zone coal, particularly in the D3 sub-zone, contains approximately 20% ash, and has a heating value of 23 MJ/kg. At the other extreme, the carbonaceous claystone is a soft, grey to dark-grey, earthy clay matrix with finely disseminated carbonaceous particles, and has greater than 80% ash and a heating value less than 2.3 MJ/kg. Between these two extremes there is a complete spectrum of coal quality developed by an increasing frequency of partings in the good coal from one end of the scale, and of an increasing percentage of carbonaceous particles in the clay matrix from the other.

For example, cut-off grade quality (9.3 MJ/kg, 59% ash) coal could occur in two different ways:

- (1) Bands of equal thickness of good coal and pure clay;
- (2) A massive low-grade coal band with 50%, by volume, high-quality carbonaceous particles in the clay matrix, or by some combination of these.

Table 7-1 presents a broad classification of Hat Creek coal and the principal related characteristics.

It is important to recognize the nature of the variability of the Hat Creek coal and the numerous zones of transition between coal and waste. These factors have a major impact on the quality of run-of-mine coal and on the processes that can be applied to improve the quality of fuel supplied to the powerplant.

A review of the data presented in Table 7-1 is helpful in understanding how the decision between fuel and non-fuel material was made. Categories 4, 5, and 6 were rejected because they contain a very high proportion (>73%) of non-combustibles: ash and moisture. Including such poor material in the fuel reduces the boiler efficiency, increases wear and tear in pulverized-coal-fired boilers, and creates handling problems in the powerplant coal system.

Category 3, the low-grade coal, was considered marginal fuel for the boilers and is discussed further in Section 7.5. The 35-year design pit contains 21.7 million tonnes of low-grade coal. The inclusion of this quantity with the boiler fuel would increase the total heat available by 2.7%, but would be accompanied by an increase of 11.9% in the quantity of ash to be processed through the boilers and disposed of.

The fuel selected for the boilers is a blend of coal from categories 1 and 2, produced by selectively mining bands of fuel and non-fuel materials down to 2 m in thickness. The resulting fuel over 35 years will average 18.0 MJ/kg with 33.47% ash and 0.51% sulphur (dry-coal basis) and 23.5% moisture content. The non-combustible content of this fuel is slightly less than 50%.

Coal beneficiation is a broad term which includes any process that improves the quality of coal. In dealing with boiler fuels, this generally implies raising the heating value and reducing the ash content of the coal. Beneficiation, however, can also be used to reduce the moisture or sulphur content. The majority of the proven beneficiation processes in use are wet, gravity-separation processes. Dry processes have been used in the past, and new dry processes are under development.

An extensive program of investigations into coal beneficiation has been completed and is outlined below.

7.3.1 Testing Programs

The initial investigations into coal beneficiation were directed towards establishing the characteristics of the proposed beneficiation plant feed and the performance of coal samples in standard laboratory washability tests. Data from these tests were used to predict the performance of the coal in various beneficiation processes. Larger samples of the coal were then processed through pilot-scale beneficiation plants. The results of these pilot plant operations were used to validate the predictions made from the laboratory tests and to develop plant design criteria.

In 1976, three bulk samples of Hat Creek coal were obtained by drilling a series of 0.91-m diameter bucket-auger holes. These three samples represented coals of different quality: 13.2, 18.1, and 20.2 MJ/kg (dry-coal basis). A portion of each sample was tested in the laboratory of Birtley Engineering to determine the size distribution of the material and to establish the sink-float characteristics. The results of this testing form the basis for the prediction of performance in gravimetric processes.

The remainder of the three bulk samples was crushed to -20 mm. The (20 mm by 28 mesh) fractions were cleaned, using heavy-media cyclones, and the -28 mesh fractions using water-only cyclones. In the heavy-media process, the clay coated the media, creating density-control problems and high magnetite loss. Part of the raw and washed coal samples were shipped to CCRL Ottawa for pilot-scale burn tests.

In 1977, three samples were obtained during the bulk sample program: two from Trench A and one from Trench B. Particular care was taken in obtaining three samples to ensure that they represented "as mined" coal rather than the finer coal obtained using the bucket-auger. These samples were sent to Warnock Hersey Professional Services, Calgary, for a laboratory testing program designed by Simon-Carves Canada Ltd. This program was essentially similar to that conducted in 1976, except that a wet attrition test, based on an Australian standard method, was introduced to permit the anticipated degradation during processing to be evaluated in the laboratory.

A 73-t sample obtained from Trench A during the bulk sample program was submitted to the Western Research Laboratory of Energy Mines and Resources, Edmonton, for evaluation of its beneficiation performance in their compound water cyclone pilot-plant. A second objective of this program was to evaluate the production and treatment of the liquid tailings effluent.

7.3.2 Conclusions Drawn from Test Results

- (1) Hat Creek coal is subject to severe breakdown in water, especially where there is attrition. The clay particles from the coal form a suspension which can interfere with gravity-separation processes;
- (2) Washability data show that the degree of beneficiation achieved would be relatively low for the effort expended; approximately half the normally expected improvement would be gained;
- (3) The finer size fractions have increasingly difficult washability characteristics. Since all cleaning processes are less efficient for the finer size fractions, the overall efficiency of any process treating the fine size fraction would be abnormally low;
- (4) The finer size fractions have increasingly higher ash content. This would limit the effectiveness of a commonly used process for thermal coals where washed coarse coal is blended with unwashed fine coal;
- (5) The better quality (D-zone) coal should not be washed, because the small improvement in quality would not offset process losses;

- (6) The tailings produced by any process-washing of Hat Creek coal would be largely a clay-water suspension, which would be extremely difficult and costly to dewater. The quantity of tailings produced by any process would be dependent on the size of the material and the duration of contact between the coal and water;
- (7) There would be some reduction in the sulphur content per unit of heating value of the coal through washing, with resulting lower powerplant sulphur emissions;
- (8) Practical beneficiation plants could be designed and operated to clean the Hat Creek coal and their performance could be predicted with reasonable confidence from laboratory tests;
- (9) The design of a practical tailings disposal scheme would require pilot-plant work and further research.

7.3.3 Alternative Beneficiation Processes Considered

A wide range of possible beneficiation processes were reviewed in the light of the results of the test programs and the process characteristics. The processes were evaluated on the basis that only coal from the A, B, and C-zones would be washed, while the better quality D-zone coal would be blended with the wash plant product. The plant feed would be divided into coarse and fine fractions by screening at a nominal 13 mm. Six practical plant schemes were selected for evaluation:

- (1) Heavy-media bath (coarse coal) and water-only cyclone (fine);
- (2) Heavy-media bath (coarse) with untreated fines;
- (3) Baum jig (coarse) with untreated fines;
- (4) Untreated coarse with dried and classified fines;
- (5) Water-only cyclones for coarse and fine coal which would require crushing coarse coal to -40 mm. This scheme would be similar to the EMR pilot process;
- (6) Heavy-media bath (coarse) with dried and classified fines.

For each scheme a preliminary modular plant design was prepared and capital and operating cost estimates made. Predictions of plant performance were made based on the available test data.

7.3.4 Tailings Disposal

The disposal of tailings from a beneficiation plant received very close attention, because of the known difficulty experienced elsewhere by the tarsand, phosphate, diamond, and china clay operations in dealing with tailings with a high clay content.

The concentration of clay particles would build up in the plant process water to a level that is unsuitable for use. Under natural conditions, the clay settles very slowly. Under lagoon storage conditions, it is anticipated that over a period of years natural sedimentation would produce a sludge with 40% solids. Any further improvement beyond this level would be extremely slow, requiring many years. The settling can be accelerated by the use of flocculants, which will produce a layer of relatively clear water for re-use in the process and a settled layer with a solids content of up to 40%. However, there are indications that the use of flocculants limits the long-term compaction that can be achieved.

The only possible alternative to lagoon sedimentation and storage is mechanical dewatering by the application of solid-bowl centrifuges. Laboratory work on Hat Creek tailings conducted at EMR, Edmonton, indicated that a cake of 75% solids material could be produced. Operating plant experience suggests that a 45% solids product is a more realistic estimate. For the total beneficiation schemes evaluated, approximately 50 million m³ of 45% solids sludge will be produced over 35 years.

The physical handling and disposal of this material presents some difficult problems. One method of disposal is to convey the sludge with the wash plant solid discard material to the Houth Meadows Waste Disposal Area, a distance in excess of 2 km. This would create conveyor problems - especially in sub-zero temperatures. Testing would be required to ensure that the sludge-solid discard mixture can be conveyed up 10% gradients. The alternative method of sludge disposal is by storage in a lagoon similar to that provided for the sedimentation process, although in this case the lagoon would be smaller.

Of the two alternative methods for sludge disposal, only the lagoon sedimentation and storage approach can be considered proven and practical. There are some serious drawbacks to using this method: lack of a suitable storage space; the cost of building retaining structures for the lagoons; and the possible permanent alienation of the land in the storage area should it prove impossible to reclaim.

The mechanical dewatering process would require further research and testing, particularly on the performance of centrifuge equipment and the handling and disposal of sludge, before it could be proposed with any confidence. Should dry disposal of the sludge prove impractical, the mechanical dewatering process could prove to have the same disadvantages as the storage and sedimentation approach and prove more expensive to operate.

7.3.5 Conclusions

An evaluation of the costs and benefits was conducted based upon the estimated capital and operating costs and the predicted plant performance of the selected schemes. The principal conclusions were:

- (1) Hat Creek coal can be beneficiated to produce a fuel averaging 21.0 MJ/kg, compared to 18.0 MJ/kg for run-of-mine coal;
- (2) Sulphur emissions could be reduced by up to 20-25% using beneficiated fuel;
- (3) The disposal of clay tailings remains a major technical and economic problem, with potentially severe environmental impacts;
- (4) Resource utilization would be reduced by 5-8% because of process losses to tailings. This is partially offset by improved boiler efficiency; but the remaining losses must be made up by mining additional tonnages of coal at higher marginal stripping ratios;
- (5) The estimated capital and operating costs of the beneficiation plant exceed the anticipated savings in the powerplant.

Based upon these conclusions, it was decided to eliminate beneficiation from further consideration in the base plan.

7.4 BOILER FUEL SPECIFICATION DEVELOPMENT

7.4.1 Introduction

The boiler fuel specification is a critical project document whose reliability must be assured for the design of appropriate boilers and ancillary equipment for the powerplant. The penalties of a design based on an incorrect fuel specification are severe and include the inability to produce at rated capacity and excessive maintenance costs.

In March, 1979, the Paul Weir Company (Weirco) were retained to review and refine the boiler fuel specification previously developed by B.C. Hydro staff. The scope of the assignment included:

1. Data Assessment

- (1) A review of the quantity and quality of the data available for the purpose;
- (2) A review of the procedures followed in analysing the data and of the conclusions drawn;
- (3) Identification of any requirements for additional testing and recommendations of appropriate testing procedures;
- (4) An assessment of bench-quality variability.

2. Fuel Assessment

An assessment of the suitability of the fuel for the design of a large steam generator and identification of any potential problem areas in design and operation.

3. Preparation of Boiler Fuel Specification

Presentation of the coal fuel characteristics and any necessary description in a form suitable for inclusion in a boiler specification document.

The first phase of the assessment program was an evaluation of the internal consistency of each of the four laboratories used, as well as the ability to reproduce results between the laboratories. This comparison was conducted on nine of the most important characteristic values. As a result of this examination, the results of one laboratory were excluded from further evaluation. Weirco does not believe that this exclusion significantly affects its overall conclusions, because the samples distributed to each laboratory were not concentrated in a limited area and the excluded laboratory's participation was relatively small. During this phase the data base was screened for apparently erratic results.

A series of regression studies were performed during the second phase of the program to establish certain relationships that are typical of Western coals. These correlations were obtained from the data accepted in Phase I:

$$\text{CO}_2 - \% = 0.058 \times \% \text{ Ash} - 0.269$$

(This equation is used to adjust the volatile matter content for CO₂.)

$$\text{Adjusted Volatile Matter} - \% = 48.90 - 0.475 \times \% \text{ Ash}$$

$$\text{Equilibrium Moisture} - \% = 25.145 - 0.0617 \times \% \text{ Ash}$$

$$\text{As Received Moisture} - \% = 28.439 - 0.1566 \times \% \text{ Ash}$$

A series of tightly controlled determinations of the Hardgrove Grindability Index (HGI) at approximately 10% moisture were made on coal samples with varying ash content. Weirco calculated the following exponential curve as the best fit for the data:

$$\text{HGI} = 24.40 e^{0.02 \times \% \text{ Ash}}$$

Because of Weirco's previous experience with the under-reporting of the alkali content of Western coals, a number of samples from each sub-zone were analyzed by two methods: the standard and a modified method. On an overall average basis, Na₂O was under-reported by 36.4% and K₂O by 17.0%. Based on these results, the alkali-content data was adjusted. These adjustments eliminated most of the undetermined error from the analytical data.

The third phase of the assessment program was the preparation of a series of data summaries for use in preparing the final boiler fuel specification. These summaries were prepared initially on a zone-by-zone basis and then on a composite basis, where each zone is weighted in proportion to its contribution to the designed pit. In developing the data summaries, the regression equations were used to adjust the volatile matter, the HGI, and the ultimate analyses except chlorine, sulphur, and ash.

Concurrently, Weirco also examined the mining plan to evaluate its impact on coal quality. The principal conclusions drawn were:

- (1) Core examination indicates that the run-of-mine coal quality can be upgraded by selective mixing practices. Material exceeding 60% ash content should be excluded to the maximum practical extent;
- (2) No further allowance should be made for dilution, because the sampling procedures have included significant quantities of waste material with the good quality coal. This included waste could not be eliminated in the evaluation of selective mining;
- (3) The short-term fluctuations are the daily or weekly swings in quality which are a function of where the coal is being mined from a given bench or series of benches. On a weekly basis, the dry-ash content can probably be controlled to approximately ± 1.5 percentage points, which equates to a heating value range of ± 0.6 MJ/kg. The daily fluctuations would be approximately double the weekly range.

7.4.3 Fuel Assessment

7.4.3.1 Testing Programs

To establish the feasibility of burning various qualities of Hat Creek coal and to develop design parameters for full-size boilers and their associated equipment, two test programs were undertaken. The initial program was on a pilot-scale research boiler, followed by a bulk burn test in a small commercial unit.

Pilot-scale Testing

Pilot-scale testing was conducted in the research boiler at the Canadian Combustion Research Laboratory (CCRL) in Ottawa.

Six samples of Hat Creek coal were tested along with a coal of known performance from Sundance, Alberta. The Hat Creek samples were obtained from the bucket-auger drilling program and consisted of three raw samples and three washed samples obtained from the test-washing program conducted by Birtley Engineering.

The principal conclusions and comments reported were:

- (1) Hat Creek coals having a heating value of 13.9 MJ/kg or more, on an equilibrium-moisture basis, can be successfully burned using conventional pulverized-fired technology. This heating value is equivalent to approximately 18.1 MJ/kg on a dry-coal basis. However, in the design of steam generators for this coal, it is imperative that reliable facilities be provided for removing the large quantities of ash that would be produced;
- (2) All three samples of raw Hat Creek coal burned during the program produced stable flames without support fuel;
- (3) The three samples of washed Hat Creek coals generally produced hotter, more stable flames than the raw coals. The removal of much of the extraneous clay by washing facilitated handling and drying noticeably. Reactivity was also improved;
- (4) High clay and moisture content in the Hat Creek coal makes handling difficult. This problem could be minimized by drying the coal to less than equilibrium moisture.

The results of the CCRL pilot-scale tests were considered in the planning of the bulk burn test at Battle River.

Bulk Burn Testing

The principal objective of the burn test was to monitor the behaviour of Hat Creek coal of a quality at or near the anticipated minimum acceptable level in a commercial scale powerplant, and to obtain data needed for steam generator and ancillary equipment design. Key parameters observed included:

- coal-handling;
- pulverizer performance;

- combustion characteristics (flame stability and ignitability);
- slagging and fouling characteristics;
- ash-handling;
- precipitator performance.

The burn tests were conducted in Unit No. 2, a 32 MW (nominal capacity) unit at the Alberta Power Ltd. (APL), Battle River Station near Forestburg, Alberta, during August, 1977.

In order to establish with confidence a lower limit for the practical burning of Hat Creek coal, the fuel selected for the test burn was below the minimum recommended by CCRL. The coal used in the test averaged 15.2 MJ/kg on a dry-coal basis, with individual tests being successfully run on samples as low as 13.0 MJ/kg. The "as received" moisture content was 21.8% (see Table 7-2).

The bulk burn test provided important practical data to establish the reasonable minimum quality of Hat Creek coal that can be used as powerplant fuel.

7.4.3.2 Comparison with Other Plants

In assessing the suitability of Hat Creek coal as a boiler fuel, it is useful to examine the design fuels for other powerplants. The Brazos Plant, San Miguel, Texas, has a 400 MW (net) unit scheduled for commercial service in early 1980, fuelled by raw lignite.

Table 7-2 compares some of the principal characteristics of the San Miguel fuel with Hat Creek performance coal and the fuel tested at Battle River.

Considering the results of the burn test and the San Miguel design fuel, the proposed Hat Creek performance coal appears to be well within the range of boiler technology and provides a reasonable basis for design.

7.4.4

The Boiler Fuel Specification

The boiler fuel specification is used to design the steam generator and also to establish a reference point for evaluation of manufacturers' performance guarantees. This is the average, or performance, fuel for the project. The second fuel that is of major significance to the project is the low-sulphur or MCS coal.

The specifications for these fuels is presented in Table 7-3.

The performance fuel is the normal product that the mining operation is designed to deliver at all times, except for a small percentage of the time when high-grade, low-sulphur coal is required for implementing the Meteorological Control System.

The size distribution of the fuel that will be delivered to the powerplant silos is a significant factor in pulverizer design. Estimates of the size distribution have been developed from the results of laboratory and field crushing tests. Table 7-4 presents two estimates of size distribution: The first is for the normal coal flow from the blending pile to the silos, and the second is for coal subjected to long-term storage and compaction prior to utilization.

Low-grade coal is a fuel of marginal quality that should not be incorporated into the powerplant fuel unless it can be improved. It is defined as having a heating value between 7.0 and 9.3 MJ/kg and an ash content of 59-66% (dry-coal basis). At a moisture content of 20-22%, it contains between 68% and 72% non-combustible materials. As discussed in Section 7.2, low-grade coal is not a simple, well-defined material, but occurs as the result of a combination of many different depositional conditions. Within the designed 35-year pit there are 21.7 million tonnes of low-grade coal averaging 63.5% ash content and 8.0 MJ/kg.

There are two alternatives available for improving the quality of the low-grade coal: washing and dry beneficiation. The wet process was quickly eliminated from consideration because of its cost, the low recovery, and the magnitude of the tailings problem that would be created. It is estimated that low-grade coal would produce three times the volume of sludge per tonne washed compared to run-of-mine coal.

Based on observations of results obtained during dry screening tests, the theory was postulated that a limited degree of beneficiation could be achieved by screening low-grade coal at 13 mm or 20 mm and discarding the undersize.

Tests were conducted on low-grade samples available in the bulk sample trench. These tests indicated that some improvement could be achieved, and a possible plant layout was developed (see Section 8). However, there are some reservations that must be eliminated by further testing before committing the construction of this plant:

- (1) The results are based on limited samples and are not necessarily representative;
- (2) The moisture content has a major influence on the efficiency of the screening;
- (3) The performance of the soft, massive, silty coal in screening is not known.

To resolve these questions will require testing materials from greater depth in the deposit when access to them can be gained.

In the plan presented in this report, it has been assumed that a low-grade dry beneficiation plant will be constructed and its costs incorporated into the cost projections. No allowance has been made for the recovery of additional heating value. Should further testing prove that the process is not practical, the material-handling system will be revised to circumvent the proposed plant. Without this plant, there are four options for disposal of the low-grade coal:

- (1) Use as a raw material for an alternative use such as alumina production;
- (2) Disposal as waste;
- (3) Stockpile for possible alternative uses;
- (4) Incorporate with the run-of-mine fuel, should experience prove that no serious problems would be created in the boilers.

7.6 FUEL QUALITY CONTROL

7.6.1 Introduction

The fuel supplied to the powerplant must maintain a consistent quality in heating value to permit stable boiler operation, and in sulphur content to meet emission standards. This consistency must be achieved over both long-term and short-term periods. The ability to meet the quality requirements over the life of the project has been established in developing the mine plan and production schedule. This work showed that on an annual basis, the 18.0 MJ/kg can be produced with a tolerance of 1.0 MJ/kg and that the 0.51% sulphur content can be met with a tolerance of 0.05%.

Having established that control can be maintained in the long-range plan, short-range control can be achieved through the selection of appropriate mining systems and the design and implementation of planning and monitoring procedures.

The key to reducing short-term fluctuations in coal quality is to smooth out the variations that occur in nature. The selected mining methods and equipment make this practical. The application of selective mining techniques eliminates much of the poor-quality material from the fuel. The number and size of shovels selected ensure that in normal operation coal can, and will, be mined from multiple locations of varying qualities. There will be some mixing of coals from different mining locations through the conveying and crushing systems. The blending scheme is specifically designed to provide a stream of reclaimed coal to the powerplant with minimal variation from the mean of the blending pile. All of these factors combine to form an effective variance-reduction system.

7.6.2 Control Program

The control program has two primary elements: planning and monitoring. During operations, each week's production will be planned and scheduled to deliver the quantity and quality of coal required to the blending plant. This coal will be laid down in a blending pile to be reclaimed to meet the powerplant's fuel requirement for the succeeding week. In a typical week, the production requirement will necessitate in

excess of 30 shovel-operating shifts. These shifts will be scheduled based on the quality of coal available to meet the required average over the week. The stacker will normally lay this material down in 100 windrows to ensure that the variability of the reclaimed fuel is minimized. The reclaimer recovers the coal, taking slices perpendicular to the direction in which the pile was constructed.

The key to being able to prepare useful weekly production schedules is the ability to predict the quality of the coal to be mined. Based on the data available from the diamond-drill holes at 150 m spacing, the heating value for an individual block of coal can be predicted with a standard error of 5%, and the sulphur, which is more erratic, has a standard error of prediction of 10-12%. When a number of different blocks are combined, as in a weekly production schedule, these standard errors would be reduced.

While this level of predictability is very good at this stage of the project, it can be improved upon considerably as more data becomes available as the mine is opened up. As the mine develops, it is planned to acquire additional data through geological mapping, in-fill drilling, face sampling and monitoring actual production to improve quality predictions to a high level of reliability.

Provision has been made in the design of the material-handling system for continuous ash monitors, which, when integrated with signals from the weightometers, can produce a record of the status of the blending pile. Composite samples will be collected once or twice a shift for laboratory analysis to provide verification of the results of the ash monitor. Sulphur monitors are still in the development prototype stage. These would be installed when proven. Until that time, sulphur monitoring would be provided through laboratory analysis of the composite samples, which could be taken more frequently, should it prove necessary.

The monitoring results on a shift or daily basis provide an opportunity for comparing actual versus forecast quality, which is useful for improving the prediction process and for initiating modifications to the current week's production schedule where required. The monitoring data would be a key item on daily production reports to management. This system provides timely data for corrective action and control.

The quality of coal reclaimed and conveyed to the power-plant will be monitored in a similar manner on the Overland Conveyor as a confirmatory check on quality.

7.6.3

Special Operations

The mine will produce two qualities of fuel: performance coal and low-sulphur coal. The low-sulphur coal will be produced only to meet the requirements of the Meteorological Control System, which is designed to eliminate unfavourable ambient sulphur dioxide concentrations. It is estimated that these conditions will occur about 2-4% of the time on a seasonal basis. The low-sulphur coal will be produced from the D-zone, which is characterized by its low sulphur and high heating value. The D-zone represents approximately 40% of the coal to be mined over the project life. When the production of low-sulphur coal is required, this coal would bypass the coal-blending facility and be conveyed directly to the powerplant. During normal operations, it would be necessary to keep one of the coal shovels in D-zone coal to control the sulphur content in the blended performance coal. One of the coal shovels will be diesel-powered for added mobility, and this shovel can be relocated to any required quality of coal to replace a shovel that is inoperative or at other times of low output.

During the early years of operation, before four generating units are on stream and the coal production is limited, there is some concern that coal quality can be controlled within acceptable tolerances. To provide assurance that the tolerances can be maintained, the coal-stacking system has been designed to permit blending piles to be built in 200 passes instead of the normal 100 passes.

TABLE 7-1

Classification of Hat Creek Coal

| Grp. | Cat. | Physical Character | Chemical Data (Dry Basis) | | | Equiv. Coal Cont. % |
|------|-------------------------|--|------------------------------|---------------|--------------|---------------------------|
| | | | % Ash | % Moisture | HHV MJ/kg | |
| 1 | good coal | shiny black, hard, thinly bedded, light | <30 | 25 | 19.0+ | 90+ |
| 2 | coal | black to brownish- black, moderately hard, well bedded, moderately light | 30-59 | 22-24 | 9.3- 19.0 | 50-90 |
| 3 | low- grade coal | black to dark-grey, hard but slightly softish, thickly bedded, light but heavier than the above | 59-66 | 20-22 | 7.0- 9.3 | 40-50 |
| 4 | silty coal | dull black to dark- grey, soft, massive and earthy, relatively heavy | 66-72 | 20 | 4.7- 7.0 | 25-40 |
| 5 | coaly clay- stone | dark-grey to grey, soft and weak when wet, rubbly when dry, earthier and heavier than the above | 72-80 | | 2.3- 4.7 | 10-25 |
| 6 | carb. clay- stone | grey, soft and very weak when wet, sheared when dry, very massive and earthy texture, heaviest | >80 | | <2.3 | <10 |

cut-off

TABLE 7-2

Comparison of Hat Creek and
San Miguel Fuel Characteristics

| Parameter | San Miguel Design Fuel | Hat Creek | |
|--|---------------------------|------------------------------|---------------------|
| | | Battle River Test Average | Performance Coal |
| Heating value - as received MJ/kg | 11.6 | 11.9 | 13.7 |
| - dry basis MJ/kg | 16.6 | 15.2 | 18.0 |
| Moisture content (%) | 30.0 | 21.8 | 24.0 |
| Ash content - as received (%) | 28.4 | 33.6 | 25.4 |
| Weight of ash/heat input kg/GJ | 24.4 | 28.3 | 18.5 |
| Weight of water/heat input kg/GJ | 25.8 | 18.4 | 17.5 |
| Weight of coal/heat input - as received kg/GJ | 86.0 | 84.3 | 73.0 |
| HGI | 92 | 44 | 45 |

TABLE 7-3

Boiler Fuel Specification

| | <u>Performance Coal</u> | | <u>Low-sulphur Coal</u> | |
|--|-------------------------|--------------------|-------------------------|--------------------|
| | <u>Dry-coal Basis</u> | <u>As Received</u> | <u>Dry-coal Basis</u> | <u>As Received</u> |
| <u>Moisture %</u> | | | | |
| Equilibrium | - | 23.1 | - | 23.6 |
| As Received | - | 23.5 | - | 24.5 |
| <u>Proximate Analysis %</u> | | | | |
| Ash | 33.5 | 25.6 | 24.6 | 18.6 |
| Volatile Matter | 33.0 | 25.3 | 37.2 | 28.1 |
| Fixed Carbon | 33.5 | 25.6 | 38.2 | 28.8 |
| <u>Ultimate Analysis %</u> | | | | |
| Carbon | 46.2 | 35.3 | 54.3 | 41.0 |
| Hydrogen | 3.6 | 2.8 | 4.0 | 3.0 |
| Nitrogen | 0.9 | 0.7 | 0.8 | 0.6 |
| Chlorine | 0.03 | 0.02 | 0.02 | 0.02 |
| Oxygen (by difference) | 15.4 | 11.8 | 16.0 | 12.1 |
| <u>Sulphur Forms %</u> | | | | |
| Pyritic | 0.13 | 0.10 | 0.04 | 0.03 |
| Sulphate | 0.02 | 0.01 | 0.02 | 0.02 |
| Organic | 0.36 | 0.28 | 0.24 | 0.18 |
| Total | 0.51 | 0.39 | 0.30 | 0.23 |
| <u>Higher Heating Value - MJ/kg</u> | | | | |
| MAF Basis | 27.2 | - | 28.3 | - |
| <u>Hardgrove Grindability Index</u> (at 10% moisture) | | | | |
| | 45.0 | - | 38.0 | - |

...continued...

Performance Coal Low-sulphur Coal

Mineral Analysis of Ash %

| | | | |
|--------------------------------|--------|-------|-------|
| SiO ₂ | } Acid | 52.6 | 54.1 |
| Al ₂ O ₃ | | 28.3 | 27.5 |
| TiO ₂ | | 1.0 | 1.0 |
| Fe ₂ O ₃ | } Base | 8.5 | 7.2 |
| CaO | | 3.4 | 3.9 |
| MgO | | 1.5 | 1.2 |
| K ₂ O | | 0.7 | 0.4 |
| Na ₂ O | | 2.1 | 2.9 |
| P ₂ O ₅ | | 0.2 | 0.1 |
| SO ₃ | | 1.8 | 2.0 |
| Mn ₃ O ₄ | | 0.2 | 0.2 |
| V ₂ O ₅ | | 0.1 | 0.1 |
| <u>Base Acid Ratio</u> | | 0.197 | 0.189 |

| | | |
|---------------------------|------|------|
| <u>T₂₅₀ °C</u> | 1500 | 1510 |
|---------------------------|------|------|

Water Soluble Alkalies %(dcb)

| | | |
|-------------------|-------|-------|
| Na ₂ O | 0.51 | 0.64 |
| K ₂ O | 0.069 | 0.026 |

| | | |
|-------------------------------|-----|-----|
| <u>CO₂ % (dcb)</u> | 1.8 | 1.2 |
|-------------------------------|-----|-----|

Fusibility of Ash °C (Range)

| | | | |
|-------------|---------------------|------------|------------|
| Reducing - | Initial Deformation | 1170-1500+ | 1160-1500+ |
| | Softening | 1210-1500+ | 1200-1500+ |
| | Hemispherical | 1250-1500+ | 1230-1500+ |
| | Fluid | 1290-1500+ | 1270-1500+ |
| Oxidizing - | Initial Deformation | 1310-1500+ | 1330-1500+ |
| | Softening | 1330-1500+ | 1340-1500+ |
| | Hemispherical | 1340-1500+ | 1350-1500+ |
| | Fluid | 1360-1500+ | 1360-1500+ |

TABLE 7-4

Size Consist - Powerplant Feed

| Size mm | Normal Coal Weight % | Stored Coal Weight % |
|------------|-------------------------|-------------------------|
| 50-25 | 10 | 7 ¹ |
| 25-13 | 16 | 15 |
| 13-6 | 17 | 16 |
| 6-3 | 15 | 15 |
| 3-1.5 | 13 | 10 |
| 1.5-0.6 | 14 | 12 |
| 0.6-0 | 15 | 25 |
| Total | 100 | 100 |

¹ Effective top size 40 mm or less.