

HAT CREEK PROJECT  
MINING REPORT - VOLUME 2  
DECEMBER 1979

ERRATA

Page 8-35	Section 8.3.7.1	First paragraph should be "... and Figure 8-12."
Page 8-36	Section 8.3.7.2	First paragraph should read "... as shown on Figure 8-10 and 8-13."
Page 8-37	Section 8.3.7.4	First paragraph should read "... is shown on Figures 8-10, 8-11 and 8-13."
Page 8-46	Table 8-3	Conveyor C1 - speed should be 2.6 m/s.
Page 9-15	Table 9-1	32 t Truck - revise second line to 4-15                    6 and add 16-17            8 18-22                    6 23-28                    5 29-35                    2
Page 10-36	Table 10-4	In Years 21 to 25 inclusive Annual Energy (MW hours) should be 201,348 not 634,525.
Page 11-12	Section 11.6.1	Second last sentence should read "... by restricting the time coal spends in ..."
Page 14-43	Section 14.4.1.5	Include the following "... material handling equipment and support facilities."

**B.C. HYDRO AND POWER AUTHORITY**  
Mining Department — Thermal Division



## **HAT CREEK PROJECT**

**MINING REPORT —**  
**Volume 2 (of 2)**

**DECEMBER, 1979.**

**Copy No.**

**32**

8	<u>MATERIALS-HANDLING</u>	
8.1	Introduction	8-1
8.2	Coal-handling	8-3
8.2.1	Coal-handling System Requirements	8-3
8.2.2	Coal-handling - Design Criteria	8-3
8.2.2.1	Design Features	8-4
8.2.3	Coal-handling Facilities - Basic Description	8-5
8.2.4	Coal-handling - Mining and Powerplant	8-6
8.2.4.1	Coal-handling - Mining	8-6
8.2.4.2	Coal-handling - Powerplant	8-13
8.2.5	Coal System Operation	8-18
8.2.6	Low-grade Coal Facilities	8-23
8.2.7	Low-sulphur Coal	8-25
8.2.8	Coal Sampling	8-26
8.2.8.1	Belt-Sampling - Mine	8-26
8.2.8.2	Belt-Sampling - Powerplant	8-27
8.3	Waste-handling	8-28
8.3.1	Waste-handling System Requirements	8-28
8.3.2	Design Criteria	8-28
8.3.2.1	Design Features	8-28
8.3.3	Waste-handling System - Description	8-29
8.3.4	Waste-handling - In-Pit	8-29
8.3.5	Waste-handling - Houth Meadows	8-32
8.3.6	Waste-handling - Medicine Creek	8-34
8.3.7	Ash-handling - Medicine Creek	8-34
8.3.7.1	Bottom-ash	8-35
8.3.7.2	Fly-ash	8-36
8.3.7.3	Economiser and Airheater Ash	8-36
8.3.7.4	Transportation of Ash to Disposal Area	8-37
8.3.7.5	Ash Disposal, Pile Reclamation, Drainage and Stability	8-38
8.4	Electrical Power Supply	8-40
8.4.1	Mine - Coal, Waste, and Ash-handling	8-40
8.4.2	Powerplant - Coal-handling	8-40

	<u>Page</u>
8.5 Recommendations for Future Testwork	8-41
8.5.1 Crushing and General Characteristics of Run-of-Mine Materials and Blended Coal	8-41
8.5.2 Borecore Test Program	8-42
8.5.3 Crushing Tests	8-42
8.5.4 Handling Characteristics	8-43
8.5.5 Screening Tests	8-43
9 <u>EQUIPMENT</u>	
9.1 Production Equipment	9-1
9.1.1 Coal Mining	9-2
9.1.2 Waste Removal	9-3
9.1.3 Operation at Maximum Capacity Rating	9-5
9.2 Support Equipment	9-7
9.2.1 Road Construction and Maintenance	9-7
9.2.2 Mine Support	9-8
9.2.3 Material-handling Support	9-10
9.2.4 Service Equipment	9-11
10 <u>MINE SUPPORT FACILITIES</u>	
10.1 Introduction	10-1
10.2 Mine Services Area	10-2
10.2.1 Location	10-2
10.2.2 Facilities Required	10-2
10.2.2.1 Administration Building	10-2
10.2.2.2 Maintenance Complex	10-3
10.2.2.3 Mine Services Building	10-6
10.2.2.4 Field Maintenance Centre	10-7
10.2.2.5 Rubber Repair Shop	10-7
10.2.2.6 Laboratories	10-8
10.2.2.7 Lubricant Storage Building	10-9
10.2.2.8 Fuel Storage and Dispensing Area	10-10
10.2.2.9 Mine Dry	10-11
10.2.2.10 Storage Areas	10-11

	<u>Page</u>	
10.2.3	Structural Description of Buildings	10-12
10.2.4	Services to Buildings	10-13
	10.2.4.1 Water Supply	10-13
	10.2.4.2 Electrical Distribution	10-13
	10.2.4.3 Heating, Ventilating, and Air Conditioning	10-14
	10.2.4.4 Lighting	10-14
	10.2.4.5 Sewage Disposal	10-15
	10.2.4.6 Fire Protection	10-15
	10.2.4.6.1 Mine Services Area	10-15
	10.2.4.6.2 Coal Handling Systems	10-16
	10.2.4.6.3 Open Pit	10-17
	10.2.4.6.4 Waste Conveyors	10-17
	10.2.4.6.5 Mine Equipment and Vehicles	10-17
	10.2.4.7 Surface Drainage	10-17
	10.2.4.8 Security	10-18
10.2.5	Construction Period Requirements	10-19
	10.2.5.1 Construction Schedule	10-20
	10.2.5.2 Construction Period Facilities	10-20
	10.2.5.3 Mine Equipment Erection Area	10-20
10.3	Utilities	10-21
	10.3.1 Water Supply	10-21
	10.3.1.1 Introduction	10-21
	10.3.1.2 Water Requirements	10-21
	10.3.1.3 Water Sources	10-22
	10.3.1.4 Proposed System	10-23
	10.3.1.4.1 Source of Supply	10-23
	10.3.1.4.2 Mine Services Area	10-23
	10.3.1.4.3 Coal Blending Area	10-24
	10.3.1.4.4 Overland Coal Conveyor	10-24
	10.3.1.4.5 In-Pit Water Supply	10-24
	10.3.1.4.6 Revegetation Nursery	10-25
	10.3.2 Mine Power Supply	10-25
	10.3.2.1 Introduction	10-25
	10.3.2.2 Electrical Loads	10-25
	10.3.2.2.1 Power Shovels	10-25
	10.3.2.2.2 Voltage Regulations	10-26
	10.3.2.2.3 Estimated Annual Power Demands and Energy Consumption	10-26
	10.3.2.3 Network Design Criteria	10-27
	10.3.2.4 System Description	10-28
	10.3.2.4.1 General	10-28
	10.3.2.4.2 Pit Area	10-29

	<u>Page</u>
10.3.2.4.3 Houth Meadows Waste Dump	10-29
10.3.2.4.4 Medicine Creek Waste Dump	10-30
10.3.2.4.5 Mine Service Facilities	10-31
10.3.2.4.6 Crushing/Blending Plant	10-31
10.3.2.4.7 Reliability	10-31
10.3.2.4.8 Construction Power	10-32
11 <u>ENVIRONMENTAL PROTECTION</u>	
11.1 Introduction	11-1
11.2 Dust	11-2
11.3 Noise	11-3
11.4 Mine Drainage and Water Quality	11-4
11.5 Land Reclamation	11-5
11.5.1 On-site Reclamation Testing	11-5
11.5.2 Waste Dumps and Embankments	11-8
11.5.3 Material Storage Areas After Abandonment	11-9
11.5.4 Transportation Corridors	11-9
11.5.5 Support Facilities	11-10
11.5.6 The Open Pit After Abandonment	11-10
11.5.7 Disturbances and Possible Resource Losses	11-11
11.6 Other Measures	11-12
11.6.1 Spontaneous Combustion	11-12
11.6.2 Environmental Services Complex	11-12
11.6.3 Monitoring	11-12
11.6.4 Archaeology	11-13
11.7 Costs	11-14
12 <u>CONSTRUCTION SCHEDULE</u>	12-1
13 <u>MANPOWER</u>	13-1

	<u>Page</u>
14	<u>ECONOMICS AND COSTS ESTIMATES</u>
14.1	Summary 14-1
14.2	Estimating Criteria 14-4
14.2.1	Introduction 14-4
14.2.2	Overall Approach to the Development of the Project Cash Flow 14-4
14.2.2.1	Equipment Productivity Standards 14-8
14.2.2.2	Equipment Cost Standards 14-8
14.2.3	Capital Cost Estimating Criteria 14-9
14.2.3.1	Buildings and Civil Works 14-9
14.2.3.2	Major Equipment 14-9
14.2.4	Operating Cost Estimating Criteria 14-13
14.2.4.1	Staff Salaries and Benefits 14-13
14.2.4.2	Hourly Labour Rates 14-13
14.2.4.3	Mine Operating Schedules 14-14
14.2.4.4	Materials Parameters 14-14
14.2.4.5	Equipment Parameters 14-15
14.2.4.5.1	Drilling and Blasting Equipment 14-15
14.2.4.5.2	Loading Equipment 14-15
14.2.4.5.3	Haulage Trucks 14-15
14.2.4.5.4	Coal and Waste-handling Systems 14-16
14.3	Capital Costs 14-34
14.3.1	Description of Costs Included in the Major Cost Centres 14-35
14.3.1.1	Engineering and Construction 14-35
14.3.1.2	Mine Property Development 14-35
14.3.1.3	Buildings and Structures 14-35
14.3.1.4	Mining Equipment 14-36
14.3.1.5	Coal Conveying, Crushing, and Blending Equipment 14-36
14.3.1.6	Low-grade Coal Beneficiation Equipment 14-37
14.3.1.7	Waste Disposal Equipment 14-37
14.3.1.8	Reclamation and Environmental Protection 14-38
14.3.1.9	Contingency 14-38

	<u>Page</u>
14.4 Operating Costs	14-41
14.4.1 Description of Costs Included in the Major Cost Centres	14-42
14.4.1.1 Drilling and Blasting	14-42
14.4.1.2 Loading and Hauling	14-42
14.4.1.3 Coal and Waste-handling Systems	14-42
14.4.1.4 Auxiliary Equipment	14-43
14.4.1.5 Power	14-43
14.4.1.6 General Mine Expense	14-43
14.4.1.7 Overhead	14-46
14.4.1.8 Royalties	14-48
14.4.1.9 Contingency	14-48
14.4.1.10 Contractor's Allowance	14-48
15 <u>MINING REPORTS AND STUDIES</u>	15-1



VOLUME 2

<u>No.</u>	<u>LIST OF TABLES</u>	<u>Page</u>
8-1	In-pit Crushing Plant - Transfer Conveyors	8-44
8-2	In-pit Incline - Coal and Waste Conveyors	8-45
8-3	Crushing, Stacking Reclaiming, and Delivery Conveyors	8-46
8-4	Low-grade Coal - Plant Conveyors	8-47
8-5	Houth Meadows Dump - Waste Conveyors	8-48
8-6	Medicine Creek Dump - Waste Conveyors	8-49
8-7	Powerplant Coal-handling Conveyors	8-50
8-8	Ash-handling Conveyors	8-51
8-9	Operating Regime - Examples of Various Operating Conditions	8-52
9-1	Mine Equipment List	9-13
9-2	Roads Scheduled for Construction	9-18
10-1	Preliminary Estimates of Consumptive Water Requirements	10-33
10-2	Water Quality Data	10-34
10-3	Total Estimated Mine Load During Peak Years	10-35
10-4	Estimated Annual Load and Energy Demands	10-36
11-1	Estimate of Areas Disturbed and Reclaimed by Year 35 and Year 45	11-15
12-1	Mine Development and Construction Schedule	12-1

<u>No.</u>		<u>Page</u>
13-1	Schedule of Peak Manpower Requirements	13-1
13-2	Manpower Schedule - Summary	13-5
14-1	Summary of Annual Costs	14-2
14-2	Breakdown of Total Estimated Capital and Operating Expenditures by Major Cost Centres	14-3
14-3	Equipment Capital Costs and Service Lives	14-10
14-4	Annual Salaries of Mine Staff	14-18
14-5	Labour Rates for Mine Operations Staff	14-19
14-6	Productivity Standards for Functional Cost Centres	14-20
14-7	Standard Costs for Functional Cost Centres	14-28
14-8	Development of Capital Costs for Major Mine Equipment	14-39
14-9	Summary of Capital Costs by Major Cost Centres	14-40
14-10	Development of Operating Costs for Functional Cost Centres	14-49
14-11	Summary of Operating Costs by Major Cost Centres	14-59
14-12	Other Costs Allocated to Mining Project	14-63

VOLUME 2

<u>No.</u>	<u>LIST OF FIGURES</u>	<u>Page</u>
8-1	Overall Project Flow Diagram	8-54
8-2	Materials-handling System Flow Diagram	8-55
8-3	Mine Conveyors and Truck Dump Stations - General Arrangement	8-56
8-4	Screening and Crushing - General Arrangement	8-57
8-5	Blending/Reclaiming - General Arrangement	8-58
8-6	Overland Coal Conveyor - General Arrangement	8-59
8-7	Waste Dump Development - Pictorial View	8-60
8-8	Powerplant - Plot Plan	8-61
8-9	Powerplant - Flow Diagram of Coal System	8-62
8-10	Powerplant - Flow Diagram - Bottom-ash Removal	8-63
8-11	Powerplant - General Arrangement - Drag-bar Conveyor for Bottom-ash	8-64
8-12	Powerplant - Flow Diagram - Fly-ash Pressure System	8-65
8-13	Powerplant - Ash-handling Scheme	8-66
8-14	Powerplant - Ash Disposal System - Isometric View	8-67
10-1	Mine Services Area - General Arrangement	10-37
10-2	Administration Building	10-38
10-3	Maintenance Complex	10-39
10-4	Mine Services Building and Rubber Repair Shop	10-40
10-5	Mine Dry	10-41

<u>No.</u>		<u>Page</u>
10-6	Mine Power Distribution Network	10-42
10-7	Typical Portable Sub-station Layout	10-43
10-8	Typical Permanent Sub-station Layout	10-44
11-1	Map of Reclamation by Year 45	11-16
13-1	Organization Chart	13-6
14-1	Overall Approach to Development of Cash Flow	14-5
14-2	Development of Equipment Productivity Standards	14-6
14-3	Development of Standard Costs Per Shift for Machine Operations	14-7

8	<u>MATERIALS-HANDLING</u>	<u>Page</u>
8.1	Introduction	1
8.2	Coal-handling	3
	8.2.1 Coal-handling System Requirements	3
	8.2.2 Coal-handling - Design Criteria	3
	8.2.2.1 Design Features	4
	8.2.3 Coal-handling Facilities - Basic Description	5
	8.2.4 Coal-handling - Mining and Powerplant	6
	8.2.4.1 Coal-handling - Mining	6
	8.2.4.2 Coal-handling - Powerplant	13
	8.2.5 Coal System Operation	18
	8.2.6 Low-grade Coal Facilities	23
	8.2.7 Low-sulphur Coal	25
	8.2.8 Coal Sampling	26
	8.2.8.1 Belt-Sampling - Mine	26
	8.2.8.2 Belt-Sampling - Powerplant	27
8.3	Waste-handling	28
	8.3.1 Waste-handling System Requirements	28
	8.3.2 Design Criteria	28
	8.3.2.1 Design Features	28
	8.3.3 Waste-handling System - Description	29
	8.3.4 Waste-handling - In-Pit	29
	8.3.5 Waste-handling - Houth Meadows	32
	8.3.6 Waste-handling - Medicine Creek	34
	8.3.7 Ash-handling - Medicine Creek	34
	8.3.7.1 Bottom-ash	35
	8.3.7.2 Fly-ash	36
	8.3.7.3 Economiser and Airheater Ash	36
	8.3.7.4 Transportation of Ash to Disposal Area	37
	8.3.7.5 Ash Disposal, Pile Reclamation, Drainage and Stability	38
8.4	Electrical Power Supply	40
	8.4.1 Mine - Coal, Waste, and Ash-handling	40
	8.4.2 Powerplant - Coal-handling	40
8.5	Recommendations for Future Testwork	41
	8.5.1 Crushing and General Characteristics of Run-of- Mine Materials and Blended Coal	41
	8.5.2 Borecore Test Program	42
	8.5.3 Crushing Tests	42
	8.5.4 Handling Characteristics	43
	8.5.5 Screening Tests	43

<u>No.</u>	<u>LIST OF TABLES</u>	<u>Page</u>
8-1	In-pit Crushing Plant - Transfer Conveyors	44
8-2	In-pit Incline - Coal and Waste Conveyors	45
8-3	Crushing, Stacking Reclaiming, and Delivery Conveyors	46
8-4	Low-grade Coal - Plant Conveyors	47
8-5	Houth Meadows Dump - Waste Conveyors	48
8-6	Medicine Creek Dump - Waste Conveyors	49
8-7	Powerplant Coal-handling Conveyors	50
8-8	Ash-handling Conveyors	51
8-9	Operating Regime - Examples of Various Operating Conditions	52

LIST OF FIGURES

8-1	Overall Project Flow Diagram	54
8-2	Materials-handling System Flow Diagram	55
8-3	Mine Conveyors and Truck Dump Stations - General Arrangement	56
8-4	Screening and Crushing - General Arrangement	57
8-5	Blending/Reclaiming - General Arrangement	58
8-6	Overland Coal Conveyor - General Arrangement	59
8-7	Waste Dump Development - Pictorial View	60
8-8	Powerplant - Plot Plan	61
8-9	Powerplant - Flow Diagram of Coal System	62

LIST OF FIGURES (Continued)

Page

8-10	Powerplant - Flow Diagram - Bottom-ash Removal	63
8-11	Powerplant - General Arrangement - Drag-bar Conveyor for Bottom-ash	64
8-12	Powerplant - Flow Diagram - Fly-ash Pressure System	65
8-13	Powerplant - Ash-handling Scheme	66
8-14	Powerplant - Ash Disposal System - Isometric View	67

## SECTION 8

### MATERIALS--HANDLING

#### 8.1 INTRODUCTION

This section of the report describes the various materials-handling systems employed in the different areas of the Hat Creek Project, i.e. mining, powerplant, waste, and ash disposal. These systems receive and deliver the different materials to their respective destinations, bearing in mind the environmental impacts, the operational requirements, the characteristics of the material, and costs as well as the safety and reliability of all components. The systems, described in Section 8.2 "Coal-handling", and Section 8.3 "Waste-handling" (including "Ash-handling"), have been developed by the following groups:

- (1) Mining and Waste-handling - Cominco-Monenco Joint Venture, Simon-Carves of Canada Ltd., and B.C. Hydro Mining Department;
- (2) Powerplant Coal-handling and Ash-handling - Integ-Ebasco/B.C. Hydro Thermal Engineering Department.

The different materials to be handled, and their destination points, are noted below:

#### Coal

With a range of heating values, above cut-off grade, i.e. +9.3 MJ/kg (d.c.b.), containing varying amounts of waste materials such as clays and carbonaceous shales not removed separately in the mining process: This material will be delivered to the stockpile for blending prior to delivery to either the powerplant silos or the powerplant storage area.

#### Low-sulphur Coal

Better-quality coal from D-zone of the deposit, with lower sulphur content, will be delivered to the stockpile areas for blending, or direct to either the powerplant silos or to the powerplant storage area.



### Low-grade Coal

Generally below cut-off grade, i.e. 7 MJ/kg - 9.3 MJ/kg (d.c.b.), containing large amounts of waste materials: This material will be delivered to a dry beneficiation plant for up-grading, with acceptable material being delivered to the stockpiles for blending with the coals described above. Reject material with high ash content will be routed to the waste dumps. Provision can readily be made to divert the reject material to alternative uses if and when these develop.

### Waste

The run-of-mine wastes can generally be classified as: (1) construction-grade material, i.e. sands and gravels for construction of retaining embankments; (2) general mine waste, i.e. clays, shales. The materials will be delivered to Houth Meadows, and in later years to Medicine Creek, for construction of embankments and dumps. Some waste materials will also be required for other construction requirements, i.e. road construction.

### Ash

Removed from the powerplant as fly-ash and bottom-ash: This will be delivered to a dry-ash disposal area in Medicine Creek.

With this range of materials, there will be many different handling problems which the design has taken into account. Their handling properties will be greatly affected by Summer and Winter conditions; moisture content could also pose problems. The gradual development of the mine and the phased installation of fixed equipment, such as conveyors and crushers, will allow the design of mining equipment to be modified as experience proves necessary.

8.2 COAL-HANDLING

8.2.1 Coal-handling System Requirements

The requirements of the Coal-handling System are:

- (1) To provide a reliable supply of coal to the powerplant silos at a consistent quality, as defined in Section 5.2.1, "Powerplant Requirements", and at the quantities shown in Table 5-6;
- (2) To supply the required daily tonnage of performance coal, based upon an 18 out of 24-hour silo-filling sequence at full load conditions;
- (3) To provide a reliable and readily available supply of higher quality lower-sulphur coal to meet the Meteorological Control System or plant upset conditions;
- (4) To handle the clays in the coal, bearing in mind the climatic conditions;
- (5) To allow for the considerable variation in the run-of-mine coal quality.

8.2.2 Coal-handling - Design Criteria

The coal-handling systems have been designed to the following criteria:

- (1) A bulk density for conveyor capacity calculations of  $800 \text{ kg/m}^3$ ;
- (2) A maximum slope for conveyors of  $14^\circ$ ; for capacity calculations, a surcharge angle of  $25^\circ$  for materials, and a  $35^\circ$  troughing angle for conveyor idlers; all conveyors designed to start-up under full load conditions.
- (3) The Conveyor Equipment Manufacturers' Association Handbook for belt load, friction factors, power calculations, and so forth.

The individual conveyor capacities are discussed in the relevant sections.

#### 8.2.2.1 Design Features

Many important design features have been incorporated into the system to handle the variety of materials and to provide both safety and reliability.

Further test work on the materials must be carried out before detailed engineering of these systems can proceed. This is discussed further in Section 8.5.

All chutes, transfer hoppers, and surge bins will be designed with slopes to reduce the incidence of material sticking to the walls. Conveyor transfer and loading points will be installed on the horizontal wherever possible, and impact rollers will be incorporated for conveyor belt protection. Skirtboards will also be fitted to conveyor transfer points to provide for safe and effective load control. This is especially important on inclined conveyors carrying lump material. Magnets and metal detectors will be installed to protect equipment from damage by tramp metal.

Dust-control measures will include water sprays for dust suppression and/or dust collection systems at transfer points. Open conveyors will be fitted with dust covers where necessary and practical.

Fire protection systems will consist generally of automatic sprinkler systems in transfer houses and galleries, and fire hydrants in other areas. The Fire Protection System for the coal-handling in the powerplant is part of a comprehensive Fire Protection System planned for the entire powerplant. This greater system has not been engineered in any detail, but it will include, as a minimum, detection and sprinkler-deluge devices for enclosed galleries and underground conveyors with fire hydrants to protect open conveyors and stockpiles.

All stockpiles will be designed to minimize spontaneous combustion. This will be achieved by compacting dead piles and ensuring that live piles are consumed within a short time, usually two weeks.

Comprehensive control schemes will be installed for both the mine and powerplant conveying systems. At the interface of the two areas, special care has been taken to integrate the systems.

The control schemes incorporate certain safety features and devices. These are designed to ensure safe and reliable operation of the conveyor system and early detection of conditions potentially damaging to the conveyors or associated equipment, or causing excessive spillage of material. These include:

- (1) Sequential starting and stopping of all pieces of equipment forming one line of transportation;
- (2) Chute-plugging switches which detect the blockage of a chute and stop the system;
- (3) Safety cords along the conveyors which allow manual stopping of the conveyor line in emergencies;
- (4) Side travel switches which stop the conveyor in case of excessive off-centre movement of the belt;
- (5) Low-speed switches which stop the conveyor in case the speed drops below normal. These also prevent the start-up of the preceding conveyor until the conveyor on which the switch is installed has reached its normal speed;
- (6) Belt-tensioning devices and controls to ensure that the correct operating tension has been reached before loading the conveyor;
- (7) Overload protection devices for motors and conveyor belts; this feature will shut down upstream equipment at a predetermined set-point to minimize overload hazards;
- (8) Holdbacks to prevent an inclined conveyor from running backwards under load;
- (9) Torque-limiting devices to prevent over-tensioning of the belt during start-up.

### 8.2.3 Project Coal Facilities - Basic Description

The proposed project coal system can be divided into the three operational areas shown on Figure 8-1.

- Operation 1: Mining, processing, blending, and storing, adjacent to the mine;
- Operation 2: Reclaiming, loading, and delivery to the powerplant;
- Operation 3: Receiving, storing, and handling at the powerplant.

Operations 1 and 2 fall under the jurisdiction of the mine. Operation 3 is under the jurisdiction of the powerplant.

The three operations are described in detail below. In the detailed engineering phase, the engineering specifications for all handling equipment will be correlated to permit standardization of major components where practical.

#### 8.2.4 Coal-handling - Mining and Powerplant

##### 8.2.4.1 Coal-handling - Mining

As noted in Section 8.2.3, the mine Coal-handling System consists of two separate operations. The operations and their main components are described below. The total quantity of performance coal to be delivered to the powerplant is  $331 \times 10^6$  t, with a peak annual requirement of  $11.64 \times 10^6$  t in Year 13. Figure 8-2 shows the system flow diagram. The main control room for the mine Materials-handling System will be located in the Coal Surge Bin House.

#### (1) Mining, Processing, Blending, and Storing (Operation 1)

##### 1. Truck Dump Stations

Three dump stations are proposed for the full capacity mining operations over the life of the mine. Located adjacent to the inclined in-pit conveyors at the Northern end of the proposed mine, the stations, designed to handle all run-of-mine material, will be built in sequence as the pit deepens. The first, near the surface, will be installed during the pre-production phase; the second in Year 8, approximately half-way down the incline; and the third in Year 20, at the bottom of the incline. Two dump stations will normally operate at any one time.

As shown in Figure 8-3, a dump station will consist of a series of separate dump pockets, each designed to handle a separate material. This section deals only with coal; low-grade coal and waste materials are described in Sections 8.2.6 and 8.3, respectively.

Coal loaded into 77-t rear dump haulage trucks by 10.7 m<sup>3</sup> hydraulic shovels will be delivered at a peak rate of 3,200 t/h to coal pockets (M1, M2) at one of the dump stations.

Each coal pocket, with a capacity of 300 t, will receive coal from rear dump trucks. A 600 mm square grizzly, covering the hopper, screens off oversize petrified wood and boulders, which are disposed of by front-end loader and truck. At the planned production rates, two pockets will be required. Initially, these will be installed at the first dump station. However, as the mine deepens and truck haulage distances increase, they will be relocated to the second and third stations, as required. A third pocket (M9) will be required when the second dump station becomes operational. This will allow delivery of coal to two dump stations, giving additional flexibility.

## 2. Primary Crushing

Run-of-mine coal will be fed from each dump-hopper at 1,600 t/h maximum by an apron feeder, which discharges the coal to a roller screen working in conjunction with a Siebra crusher. The roller screen will allow coal at -200 mm to pass through, while larger pieces are crushed by an overhead crushing mechanism. Uncrushable material, such as petrified wood, lifts this mechanism and passes through to a short rejects-conveyor, which discharges the material to a stockpile for disposal by a front-end loader and truck. Coal at -200 mm will be discharged to a transfer conveyor and delivered to the mine Coal Conveyor. Table 8-1 gives details of the conveyors in this area.

## 3. Mine Coal Conveyor

The mine Coal Conveyor (M8A), with 1,400 mm-wide steel cord belt and designed to handle 3,200 t/h, receives coal from the transfer conveyors and delivers it via the Conveyor Drive and Transfer House to the secondary screening and crushing plant. The conveyor initially will consist of one flight, with two more (M9A, M10A) being installed in series to follow the mine development sequence as noted above. Table 8-2 gives details of the conveyors. In the event of a breakdown of this system, a back-up is provided by use of the Low-grade Coal Conveyor described in Section 8.2.6. As shown in Figure 8-4, a bypass conveyor (C1) located in the Conveyor Drive and Transfer House will be used to deliver coal from the Low-grade Coal Conveyor (M8D) to the Coal Transfer Conveyor (C2) and to the Screening and Crushing Plant.

#### 4. Secondary Screening and Crushing

Coal received from the mine Coal Conveyor (M8A), or from the Bypass Conveyor (C1), is discharged to a 1,400 mm-wide transfer conveyor (C2) and delivered to a set of four surge bins, as shown on Figure 8-4. Table 8-3 gives details of the conveyors in this area. A rotating chute will distribute the coal feed equally into the bins. Reclaim from each of the 150 t-capacity bins at 1,000 t/h will be by apron feeders (C3A, 3B, 3C, 3D). Each feeder will discharge to a screen-feed conveyor (C4A, 4B, 4C, 4D) delivering to the Screening and Crushing Plant. The coal will be discharged from each delivery conveyor to a two-deck inclined vibrating screen (C5A, 5B, 5C, 5D). The top decks of these screens will be fitted with 50 mm square woven wire surfaces to classify by size at 50 mm nominal. The lower deck will be fitted with mild steel plate and function as a carrying deck.

Screen overflow will be discharged to an impact-type crusher (C6A, 6B, 6C, 6D), sized to handle up to 350 t/h for reduction to -50 mm. Screen underflow will be carried forward to blend with the crusher product. The -50 mm coal will gravitate to a two-way chute for diversion to either of two parallel conveyors (C7A, 7B). One of these two conveyors will also receive coal from the low-grade coal facilities described in Section 8.2.6.

These conveyors transfer to a second pair of conveyors (C8A, 8B), which then deliver the coal to the Sampling House. A further transfer of the coal to a third pair of conveyors (C9A, 9B) will occur in this house. Either of this third pair of conveyors will deliver the coal to the Stockpile Conveyor (C10) in the Blending/Storage Yard, or to the Reclaim/Bypass Conveyor (C12) if the coal is to be delivered directly to the powerplant.

The provision of four separate screening and crushing lines and a second conveyor line to the Blending Stockpile Area ensures maximum reliability.

#### 5. Blending/Storage Piles

The purpose of the Blending/Storage System is two-fold: (1) to smooth out the short-term variations in the quality of coal received from the mine; and (2) to provide a surge capacity in the flow of coal from the mine in case of breakdown of the Overland Conveyor to the powerplant or powerplant problems.

The crushed coal, at -50 mm, from the crushing plant or low-grade coal beneficiation plant, will vary in quality from the cut-off grade of 9.3 MJ/kg (dry basis) to about 22.0 MJ/kg. The average

quality of the coal to be delivered to the powerplant will be 18 MJ/kg. Therefore, the blending system selected must be capable of producing performance coal. The quality of coal delivered to, and reclaimed from, the blending piles will be continuously monitored, as described in Section 8.2.8. This will allow the mine coal production schedule to be adjusted to ensure the delivery of performance coal to the powerplant.

Several factors were considered in selecting the size and location of the blending/storage piles, and a study to determine their location was carried out. The study considered the powerplant storage requirements to eliminate unnecessary duplication of facilities, provide a reliable supply, furnish operational control, ensure efficiency of operation, and meet environmental standards.

Earlier studies by the Cominco-Monenco Joint Venture on stockpile size to suit the predicted blending requirement for the varying qualities of coal and on mine dust, were also taken into consideration. The location selected for the piles is adjacent to the mine mouth in an area that has room for expansion.

The selected layout of the facility, as shown on Figure 8-5, comprises two regular blending piles, each with a maximum 300,000 t capacity. Each pile will be equal to about one week's supply of performance coal for full-load operation of the powerplant. Normally, one pile is being built while the other is being reclaimed.

The operating size of the blending piles will vary according to the long-term and short-term coal forecasts of the powerplant. These forecasts enable the mine to schedule coal production and blending pile construction accordingly. Spontaneous combustion hazards will also be reduced by such planning and scheduling. The size of the piles will also vary in the early years of operation as the powerplant construction proceeds to full production from the four generating units, i.e. from 500 MW to 2,000 MW. Quality control of the coal in the piles during these periods is assured by varying the pile construction technique, as given in Section 7.6.3.

The size and configuration of the piles is influenced by the space limitations of the site and the selection of 300,000 t as the size of a blending pile. Other factors include the size and availability of the required equipment, and the stockpile efficiency, which is determined by the ratio of pile length to width. The selection of the blending method is influenced by the method in which a pile is deposited and reclaimed. The Windrow Method, as shown on Figure 8-5, has been selected over the Chevron Method, as the most suitable for Hat Creek. The Windrow Method gives better blending efficiency by reducing particle segregation and reduces dusting potential.



The system will use a slewable, luffing, rail-mounted stacker receiving coal at 3,200 t/h from the Central Stacking Conveyor (C11), 1,400 mm wide, via a travelling-belt tripper. The luffing boom will deposit the coal by the Windrow Method. Normally, the stacker constructs a pile of 100 windrows, but is designed to construct a pile of 200 windrows. The stacker has its travelling speed controlled by a weigh scale, and is in other respects automatically controlled. This enables windrows of uniform cross-section to be built, which allows maximum use of the storage space and gives better assurance of quality. Table 8-3 gives details of the conveyors in the area.

The stacker, after building one pile, slews through 180° and is able to begin building the other pile with a minimum of delay.

Major specifications of the stacker are:

Capacity	- 3,200 t/h
Boom length	- 55 m
Slewing arc	- 200° minimum
Lifting height	- 18 m
Travelling speed	- 3 to 30 m/min.

Normally, all coal arriving from the mine would pass through the Blending/Storage System after crushing. However, as described in Section 8.2.7, a bypass will be provided to allow direct delivery to the powerplant of low-sulphur coal to meet MCS conditions or to replenish low-sulphur storage stockpiles at the powerplant.

As recommended in the CMJV Dust Study, certain features have been incorporated into the Blending/Storage System. As shown on Figure 8-5, the piles will be specially contoured and oriented to minimize dusting potential, considering the prevailing wind directions, i.e. in a North-East - South-West direction. A specially constructed berm along the Southern edge of the piles will provide a windbreak. A dust-suppression system using water guns will also be installed. The stacker discharge boom will be equipped with a telescopic chute to reduce dusting in the stacking operation, and all transfer points on the system will be equipped with dust-suppression equipment.

Normally, because of the short residence time, the blending/storage piles would not be compacted. Provision would be made for compacting if this should prove necessary to prevent spontaneous combustion.

(2) Reclaiming, Loading, and Delivery (Operation 2)

1. Reclaiming and Loading

To ensure the delivery of performance coal in the desired quantities to the powerplant, close co-ordination will be required between powerplant and mine operations. The powerplant requirements for coal of performance quality will be advised in advance, according to short-term and long-term electricity production schedules. Accurate forecasting of coal requirements is necessary to enable the mine to schedule production of the required quantity and quality of coal to the Blending System.

The Reclaiming System consists of a single rail-mounted bucketwheel reclaimer with a reversible shuttle conveyor. The reclaimer is also equipped with a moving rake which moves the coal down the face of the pile to the bucketwheel moving across the face at the foot of the pile. The rake aids in the blending of the coal and allows for a safer operation, i.e. it does not allow undercutting of the pile. As shown on Figure 8-5, the reclaimer reclaims blended coal from one pile, feeding it to the Reclaim/Bypass Conveyor (C12) on the South side of the Blending/Storage Yard. After reclaiming one pile, the reclaimer travels back to the Eastern side of the yard, where a transporter car transfers it to the other pile which the stacker has built. After reconnection of the power supply, the Shuttle Conveyor will be repositioned and its direction of travel reversed.

Reclaiming operations will then recommence, with the reclaimed coal being fed to the other 1,400 mm-wide reclaim conveyor (C13) on the Northern side of the yard, which will deliver it to a collecting conveyor (C14) 1,400 mm wide feeding the Overland Coal Conveyor. Stacking operations will then resume to rebuild the first pile.

The reclaimer has a maximum capacity of 3,000 t/h. Normal flow to the powerplant is 2,500 t/h, based upon filling the powerplant silos for 18 out of 24 hours. When necessary, the reclaim/delivery facilities could be operated at up to 3,000 t/h to simultaneously fill the powerplant silos and replenish the dead stockpile at the powerplant after prolonged outage of the Reclaim/Delivery System.

The most important features of the reclaimer are:

- track mounted with reversible operation;
- bridge span between tracks - 51 m;

- number of bucketwheels - 1;
- capacity - variable from 3,000 t/h to 500 t/h.

An emergency back-up system is also provided. This consists of a portable conveyor supplied with coal from front-end loaders and dozers, which will be supplied from mine operations. The coal is delivered to the Reclaim Conveyor via a hopper.

## 2. Overland Conveyor

A single conveyor in four flights (C15, C16, C17, and powerplant Receiving Conveyor 1) carries coal from the reclaiming area to a Main Transfer House at the powerplant. This conveyor, with steel cord belt, normally operates at a capacity not exceeding 2,500 t/h, based upon an 18-hour silo-filling sequence. The maximum design capacity of the Overland Conveyor, however, is 3,000 t/h to replenish powerplant stockpiles as well as deliver 2,500 t/h to the powerplant silos. Tables 8-3 and 8-7 give details of the conveyor flights and Figure 8-6 shows the layout.

The conveyor is mounted near ground level, with cut and fill sections to suit the land contours. Adequate clearance is provided to permit clean-up of spillage. It passes underneath the project access road in one location. A 5 m-wide road allowance is included alongside the conveyor for inspection and maintenance.

The conveyor is covered to prevent dusting and, in certain areas, a totally enclosed gallery may be used, e.g. where deep snowdrifts can occur. An allowance for such enclosures has been included in the capital cost of the conveyor.

A study of the reliability of a number of overland conveyors has been carried out. However many overland conveyors are provided, there is still a risk that the coal supply may be interrupted. Therefore, as an insurance, a minimum supply of 14 days' coal at continuous full-load conditions will be stored in the powerplant storage yard. This storage facility is described in Section 8.2.4.2. This amount of storage is sufficient to maintain operation of the powerplant for the longest predictable major breakdown, i.e. the complete replacement of one conveyor belt.

Based on this reasoning, a single overland conveyor has been selected. The provision of four flights, with a change in direction occurring at the end of the first and third flights, allows a conservative route for the conveyor line to be chosen. This results in

shallower inclines for the conveyor and access roads compared with a direct route, minimizes contact with the highway, and reduces belt tensions to allow selection of proven belts giving better assurance of reliability.

#### 8.2.4.2 Coal-handling System - Powerplant (Operation 3)

##### General

The powerplant Coal-handling System includes:

- (1) A facility for receiving the discharge from the Overland Conveyor System;
- (2) A Silo-filling System to deliver coal to the silos above the pulverizers from the Overland Conveyor or from powerplant storage;
- (3) Powerplant storage and reclaiming facilities.

Powerplant coal-related design data, including coal requirements, are assembled in the Station Design Manual (SDM) compiled by the powerplant consultant, Integ-Ebasco.

In 18 hours, the Silo-filling System would provide the coal required by four units at full load for 24 hours.

##### Summary of Components

The main components of the powerplant Coal-handling System, in addition to the Receiving Conveyor (1) from the powerplant perimeter, are:

- (1) The Main Transfer House, including a 600 t surge bin and crushers for frozen coal;
- (2) Conveyors 4A and 4B from Main Transfer House to Surge Bins 1 and 2;
- (3) Surge Bins 1 and 2 in the Auxiliary Bay;
- (4) Feeders and conveyors for transfer from Surge Bins 1 and 2 to silo conveyors;

- (5) Silo conveyors;
- (6) Silos;
- (7) Stocking-out Reclaiming Conveyor 18;
- (8) Stacker-reclaimer and live storage facility;
- (9) Dead-storage facility, mobile equipment, and emergency reclaim facilities;
- (10) Powerplant coal-handling control facilities;
- (11) Powerplant coal-handling sampling/testing facilities.

Figure 8-1 shows the powerplant Coal-handling System diagrammatically as part of the overall project coal system.

Major features of the coal-handling layout are shown on the plot plan of the powerplant, Figure 8-8.

Figure 8-9 shows the detailed coal-handling diagram for the powerplant.

Table 8-7 lists the conveyors and belt-feeders for the powerplant Coal-handling System.

#### Description of Components

A description of the powerplant Coal-handling System follows:

##### 1. Final Flight of the Overland Conveyor

The Receiving Conveyor (1) at the powerplant is an extension of the Overland Conveyor and operates as part of that complete system. This conveyor (1) is a single, covered belt, above ground, and running North/South on the East side of the cooling towers. Should the Overland Conveyor System be unavailable for any reason, it does not preclude operating the remainder of the powerplant Coal-handling System or prevent the supply of coal to the silos, because the powerplant has storage under its direct control, as described in items 9 and 10.

Capacities of the Overland Conveyor and Receiving Conveyor (1) are:

Normal maximum            2,500 t/h

Peak capacity             3,000 t/h

Normally, the Overland Conveyor will empty before being stopped. Should the coal on the Overland Conveyor have to be dumped, the silo in the Transfer House is used. The Overland Conveyor can hold about 900 t. Excess coal will be dumped via the Excess Discharge Conveyor (17) to the ground.

## 2. Main Transfer House

This Transfer House is the main coal receiving and distribution point for the powerplant. It will contain a 600 t surge bin and transfer conveyors for normal delivery of coal to the powerplant silos or, when desirable or necessary, to the powerplant Storage System.

Two 100%-capacity frozen lump crushers, with variable-speed inlet feeders, are included for recrushing frozen coal reclaimed from the storage areas in Winter, if and when necessary. Screens may be included ahead of the crushers after a full evaluation of crusher alternatives. Normally, the crushers are bypassed. Protective devices such as metal detectors are provided.

The Transfer House is heated and includes dust-control and fire-protection facilities.

## 3. Powerhouse Conveyors (4A and 4B)

Two 2,500 t/h inclined Powerhouse Conveyors (4A and 4B), housed in a common enclosed and heated gallery, carry coal from the Main Transfer House to the Surge Bins (1 and 2) in the Auxiliary Bay of the Powerhouse. These conveyors enter the Powerhouse between Boilers 1 and 2. Normally, one conveyor operates and the other is on standby.

## 4. Powerhouse Surge Bins and Transfer Conveyors

Surge Bins (1 and 2), each of 100 t capacity, are located respectively between Boilers 1 and 2 and Boilers 3 and 4 in the Auxiliary Bay. Surge Bin 1 is fed directly from the Powerhouse Conveyors (4A and 4B). Surge Bin 2 is fed from the Powerhouse Conveyors (4A or 4B) by two 2,500 t/h Transfer Conveyors (5A and 5B). Normally, the surge bins are fed by either of the inclined Powerhouse Conveyors (4A or 4B) in conjunction with either of Transfer Conveyors (5A or 5B).

## 5. Powerhouse Surge Bin Outlet Feeders and Conveyors

Discharge from the Powerhouse Surge Bins (1 and 2) is by variable-speed discharge feeders and manually-operated gates. The feeders supplying the adjacent silo conveyors feed direct. Those supplying the outer silo conveyors feed to 400 t/h Intermediate Conveyors (6A, 6B, 7A, and 7B). For each conveyor there is a standby of equal capacity.

## 6. Silo Conveyors

Over the row of four silos on each side of each boiler, a single silo-filling conveyor (10A/B, 11 A/B, 12 A/B, and 13 A/B) of capacity 400 t/h each delivers coal to a travelling tripper, which fills the silos.

Simultaneous filling of all rows of silos, so that daily coal demand for full-load boiler operations can be completed in 18 hours out of a 24-hour period, is tentatively planned as the operating mode. However, the system design is flexible and allows continuous filling with varying boiler loads.

Individual silos are filled on a "layering" basis.

The silo-filling operation is automated to a reasonable degree, but is under constant supervision from the coal-handling control panel, from which the filling rate can be manually adjusted.

Key signals (e.g. low silo-level alarms) are repeated in the boiler control panels.

## 7. Silos

Eight silos, four on each side, are provided for each boiler. Each silo feeds one pulverizer. The silos each hold up to eight hours' capacity for one pulverizer at full load with performance coal. Normally, seven mills carry full load. Silos are of circular construction, with conical bottoms of stainless steel with a 78° slope. Manual gates are fitted at each silo outlet, and provision is made for emptying the silo contents in an emergency.

The silo gates, downpipes, feeders, and emergency emptying chutes are part of the boiler.

## 8. Stocking-out Conveyor

A single 2,500 t/h conveyor (18) feeds from the Main Transfer House to the live storage area. It discharges to the stacker/reclaimer.

Conveyor (18) is tentatively of the open type. A study would be made of enclosing this conveyor along with the live storage pile (see below).

## 9. Stacker/Reclaimer - Live Storage

The base scheme includes a live storage pile of up to 2½ days' supply at full load (about 100,000 t) in two sections. This ensures that the powerplant has performance coal and low-sulphur coal directly and promptly reclaimable to assure continuity of power production at all times, including short interruptions in the coal supply from the mine.

Lower-sulphur coal is stored at one end of the live pile in readiness for coal switching for the MCS.

A travelling, rail-mounted stacker/reclaimer stacks coal at up to 2,500 t/h on the live storage piles adjacent to the track.

The live storage piles are reclaimed regularly to avoid spontaneous combustion.

Reclaim from the uncompacted live storage piles is by the bucketwheel on the stacker/reclaimer. Alternatively, a bottom-reclaim system with ploughs may be used. Reclaim capacity is 2,500 t/h.

The live storage pile may be roofed so that, for a reasonable period, the powerplant could directly reclaim dry coal regardless of climatic conditions.

## 10. Dead Storage

Adjacent to the live storage area, a compacted dead storage pile of approximately 30 days' capacity at full station load could be built. This would allow the powerplant to be self-sufficient for a reasonable period if a major interruption in coal supply from the mine were to occur. The dead storage would be compacted to avoid spontaneous combustion. This storage would be built by mobile equipment taking coal from the live storage area. A minimum of 14 days' supply in dead storage is proposed.



Reclaim would be by mobile equipment to the live storage reclaimer. Emergency reclaim hoppers and conveyors are also included.

The powerplant Coal-handling Plant is designed so that live or dead storage can be rebuilt following heavy usage, while also receiving coal and filling silos at the normal rate of 2,500 t/h. Accordingly, the Supply System (operation 2) will have a maximum capacity of 3,000 t/h.

Part of the dead storage area would be stocked with lower-sulphur coal required for MCS operation.

It is anticipated that, in addition to giving the power-plant operators an assured supply of coal at all times and rapid retrieval of lower-sulphur coal, the live and dead storage facilities may also be used to ease temporary operating problems which may arise from difficult coal quality or other operational factors.

#### 11. Other Powerplant Coal-handling System Features

Many items of detailed engineering related to the coal system will be performed in the final design stage, particularly after the major boiler and coal-handling equipment is ordered.

Particularly important are:

- (1) The basic control and instrumentation scheme, including the necessary sampling and testing facilities;
- (2) Environmental protection (e.g. dust control, noise control).

#### 8.2.5 Coal System Operation

##### General

Detailed operating regimes for the components of the project coal system can only be finalized when engineering has advanced into the detailed stage. However, the basic operational concepts are:

- (1) Power production for the next period (say one month) will be planned ahead;

- (2) The coal requirements will be determined and communicated to both powerplant coal operators and to the mining operation;
- (3) Mine production will be scheduled to construct one blending pile, while coal from the other pile is reclaimed and delivered to the powerplant;
- (4) When a new blending pile is complete and the other pile is reclaimed, the stacker and reclaimer are interchanged and the process repeated;
- (5) In normal operation, coal deliveries will be balanced to powerplant consumption;
- (6) Sampling and quality control facilities in operations 1 and 2 will monitor delivered quality. The powerplant will also sample quality of coal delivered to the silos;
- (7) The blending piles act as a surge between the mine and the Overland Conveyor, and the powerplant stockpiles provide surge capacity between the Overland Conveyor and the silos. This allows reasonable flexibility to maintain efficient operations in all areas despite temporary imbalance.

Planning has recognized that there may be short periods of emergency when the quantity and quality of the supply of coal to the powerplant does not meet the requirements of the powerplant. Table 8-9 lists some of these possible situations and typical corresponding corrective actions. Strategically placed stockpiles are integrated with the mining and powerplant operations. This provides a means of dealing with emergencies without affecting electricity production.

The overriding concept in operation 3, the powerplant coal operation, is to ensure reliability of power production, with coal of adequate quantity and quality available at all times.

#### Coal-handling Control System

The instrumentation and control of the powerplant system will be centralized on a separate panel located in the main control room of Generating Units 1 and 2 in the powerhouse. Further consideration will be given to the location of a separate panel in the Main Transfer House for remote control of the storage facilities. A programmable logic controller will be used for the Coal-handling System because of its flexibility and suitability for program changes. This may be integrated with the powerplant process control computer. Program changes will be available to suit various layering techniques required for the mixing of coal in the silos and to change silo-filling programs when handling free-flowing or sticky coals.

The objectives of the Control System are:

- (1) To provide an automatic Silo-filling System in which the rate of fill and silo levels can be varied to meet predetermined powerplant coal demand, short-term adjustments, handling ability of the coal, and availability of the coal-handling equipment;
- (2) To provide manual selections and indications so that the system can be operated manually;
- (3) To provide operational protection of the Coal-handling System.

Silo feed rates are based on unit load, and silo operating levels are adjusted to suit the flow characteristics of the coal and silo-filling requirements. The readout from the belt scale on the third flight of the Overland Conveyor is available in the powerplant control room to assist the operators in setting the loading sequence.

Intermittent operation of the mine Reclaim System and overland conveyors will be avoided.

Coal delivered from the mine is normally directed to the boiler house silos. When handling free-flowing coal after the silos are filled, the powerplant operators may divert the coal to their stockpiles or instruct the mine to stop delivery.

The powerplant Coal-handling System comprises several sub-systems, each connected in independent series, as described in items 1 to 6 below.

The coal-delivery sub-system from the mine, the powerplant, and normal and emergency reclaim systems, discharge coal to the Main Transfer House Surge Bin. Each one is connected in independent series, with plugged chute controls in their discharge chutes located above the surge bin. The bin in the Main Transfer House provides surge capacity for the above systems.

Surge Bins 1 and 2 in the Auxiliary Bay provide surge capacity for the Powerhouse conveyors fed from the Main Transfer House.

An independent system for each row of four silos delivers coal from the Surge Bins (1 and 2) to the silos.

The powerplant stockout sub-system is interlocked with the overland conveyors by a plugged chute detector below the variable splitter in the Main Transfer House.

All sub-systems interlocked in series are provided with timers for sequential starting. Initiation of any stop control on any conveyor in series automatically stops all conveyors upstream of the conveyors on which the stop is made.

#### 1. Overland Conveyors to Surge Bins in Main Transfer House

Receiving Conveyor (1) is part of the Overland Conveyor System, which is interlocked with the high-level chute control in the Main Transfer House. Initiation of any stop of the controls on the overland system or of the variable splitter in the Transfer House switches off all equipment back to the reclaimers at the blending piles.

#### 2. Surge Bin in Main Transfer House

Activation of the high level control automatically speeds up the discharge feeders and/or starts up the Excess Discharge Belt 17. Activation of the plugged chute controls in the chutes feeding the surge bin stops the Overland Conveyor System, the Reclaim System from live storage (Conveyor 18), and the Emergency Reclaim System (Conveyors 19A and 19B). Operation of the low-level control stops the Discharge Feeders.

#### 3. Delivery from Main Transfer House Surge Bin to Surge Bins 1 and 2

Feeders (2A and 2B), the frozen coal crushers, Powerhouse Conveyors (4A and 4B), Transfer Conveyors (5A and 5B), form two independent sub-systems operating in parallel and receiving signals from the high-level control in the Powerhouse Surge Bins (1 and 2).

The variable splitter at the discharge of Powerhouse Conveyors (4A and 4B) automatically adjusts to equalize the loads in the Powerhouse Surge Bins (1 and 2). Indications from the silo load cell determine when the silo for any pair of units is nearly full. When this occurs, the feed from the Transfer House automatically reduces by 50% and, after a delay, the splitter positions the bypass gate to deliver all coal to the surge bin serving the silos not yet filled.

#### 4. Delivery System from Surge Bins 1 and 2 to Silos

The low-level controls of the surge bins are interlocked with their discharge feeders in order to maintain an operational layer of coal on the feeders.

Limit switches confine operating limits and indicate positions for tripper or shuttle conveyors over each silo. Movement of trippers (or shuttles) is under automatic control, with manual override.

All systems, after manual initiation, are automatically controlled.

5. Reversible Stock-out from the Main Transfer House to the Live Stockpile and Reclaim for Normal Reclaim

(1) Stock-out mode:

The Stocking-out Conveyors (16 and 18) operate with the Bucketwheel Conveyor (20); the reversing drives are blocked out and the system interlocked with the Overland Conveyor via the plugged chute control below the splitter in the Main Transfer House.

(2) Reclaim mode:

The bucketwheel, the Stocking-out Conveyors (16 and 18) operating in reverse, and Bucketwheel Conveyor (20) are connected in series and interlocked with the plugged chute and system controls.

6. Emergency Reclaim from Storage

The Dual Conveyor Feeders (14A/B, 14C/D, and 14E/F) below the emergency reclaim hoppers are connected in series with the Dual Emergency Conveyors (15A/B and 19A/B). Both systems are interlocked with the plugged chute control in the Main Transfer House Surge Bin.

General

All silos, distribution bins, and the Main Transfer House Surge Bin are mounted on load cells, and each is equipped with high-level and low-level controls or alarms. Indications of the amount of coal in each bin and silo is shown in the control room.

All feeders from the surge bin and distribution bins have variable-speed drives automatically controlled, but manually adjustable from the control room. Low-level controls switch off the feeders.

The variable splitters in the Main Transfer House and above Powerhouse Surge Bin 1 are motorized with position indicators, and are manually adjustable from the control room.

All flop gates are motorized and may be manually positioned from the control room. In addition, the loads in the Surge Bins (1 and 2) will automatically adjust the variable flop gate splitter into which the Powerhouse Conveyors (4A and 4B) discharge. Limit switches indicate the position of the gate.

All chutes are equipped with plugged chute detectors. All conveyor belts are equipped with:

- (1) Belt misalignment switches (two at each head end and two at each tail end);
- (2) Emergency pull-cord trip switches on both sides of the conveyor;
- (3) Speed switches.

Details of the control of crushers, belt scales, magnetic separators, and metal detectors are not included in this preliminary description.

#### 8.2.6 Low-grade Coal Facilities

The low-grade coal facilities are designed primarily to beneficiate the low-grade coal, i.e. coal between 7.0 and 9.3 MJ/kg. However, coal which is above 9.3 MJ/kg can also be routed through the facility for beneficiating when problems are encountered in making target quality. The facility also allows flexibility in the selective mining process by handling coal which contains excessive amounts of waste materials. Also, should the secondary screening and crushing plant be required to handle low-sulphur coal, or should it be out of commission, the low-grade coal facility can be modified to handle normal-grade coal at a reduced rate.

The estimated quantity of low-grade coal to be handled over the life of the mine is  $21.7 \times 10^6$  t. Details of the low-grade coal beneficiation study appear in Simon-Carves' report, dated August 1979. Further testing on a pilot-plant scale is required to confirm the feasibility and design parameters for low-grade coal beneficiation before final design. Figures 8-2 and 8-4 show the layout of the facility, and Tables 8-2 and 8-4 give details of the conveyors.

The low-grade coal is delivered to the low-grade coal truck dump pocket (M4). The truck dump pocket, also capable of accepting waste material or coal, is fitted with a grizzly having 600 mm square openings.

Coal reclaimed from the pocket by a reciprocating push feeder discharges to a cascading vibrating grizzly with 200 mm square openings. The grizzly overflow discharges to an impact-type crusher for size reduction to -200 mm. Grizzly underflow, together with the crusher product, gravitates to a 1,400 mm-wide transfer conveyor for transport to the Low-grade Coal Conveyor, also 1,400 mm wide, which feeds it to the Low-grade Coal Conveyor (M8D), terminating at the drive and Transfer House. A transfer conveyor (LG1) then delivers it to the low-grade coal bins.

The Low-grade Coal System is designed for 1,000 t/h. However, the Conveying System is designed to handle up to 5,000 t/h to allow greater flexibility by providing a back-up system for both coal and waste systems. If coal is being handled, a bypass conveyor (C1) in the Drive and Transfer House allows the coal to be diverted to the Transfer Conveyor (C2) feeding the coal bins. Waste-handling on this system is described in Section 8.3.

Low-grade coal is discharged to one of the two low-grade coal bins by means of a reciprocating chute. The reclaiming of low-grade coal at 500 t/h from each bin is by apron feeder (LG2A, 2B). Each apron feeder feeds to a low-grade coal screen feed conveyor (LG3A, 3B) delivering to the Screening and Crushing House for low-grade coal. Each conveyor then discharges its product to an inclined three-deck vibrating screen (LG4A, 4B). The top deck is fitted with a 50 mm square opening woven wire deck, while the middle deck is fitted with a rod deck having 13 mm spacings. The bottom deck is blanked off with mild steel plate and acts as a carrying deck. The screen can be upgraded to a capacity of 1,000 t/h by blanking off the middle deck when the system has to handle regular grades of coal as described in Section 8.2.4.1.

The +50 mm oversized material carried on the top deck is discharged to an impact-type crusher (LG5A, 5B) for reduction to -50 mm. Material sized 50 x 13 mm passes via a chute to join the crusher product. A portion of this product is directed to a bulk density meter (LG6A, 6B) for ash monitoring. The ash value determines to which conveyor the +13 mm low-grade coal is discharged. Should a low ash-reading indicate the +13 mm fraction as acceptable for inclusion in the blended product for the powerplant, the fraction gravitates to the Coal Conveyor. Conversely, a high ash-reading causes the flop gate in the two-way chute to automatically divert the +13 mm coal to the Reject Conveyor.

The -13 mm low-grade coal carried on the lower deck is similarly sampled on a bulk density meter (LG6C, 6D) to determine ash. A two-way chute and flop gate diverts this product either to the Reject Conveyor (LG1) or to the Product Conveyor (C7B), depending on the measured ash.

The Reject Conveyor terminates at a transfer house, where the product is discharged to a second reject conveyor (LG8). This conveyor delivers it to a transfer house, where the product is fed to a two-way chute for routing either to the Houth Meadows Waste Dump, to Medicine Creek in later years, or for other uses.

#### 8.2.7 Low-sulphur Coal

The Coal-handling System will be required to convey low-sulphur coal from the mine direct to the powerplant, bypassing the blending piles.

The low-sulphur coal will be required to meet MCS conditions, or to replenish the low-sulphur portion of the stockpiles at the powerplant, whenever these become depleted.

Low-sulphur coal at a peak rate of 3,000 t/h will be routed from the mine face to the mine Coal Conveyor (M8A), which delivers the coal to the Screening and Crushing Plant. The low-sulphur coal will be crushed to -50 mm, and routed through the Sampling and Transfer House via Product Conveyors C7A and C8A to Product Conveyor C9A. Product Conveyors C7B, 8B, and 9B provide back-up to this delivery line and would also handle normal-grade coal production, if required, from the low-grade coal facility to the blending piles.

The low-sulphur coal transfers to the Reclaim/Bypass Conveyor C12, bypassing the blending piles, and then via the Overland Conveyor System to the 600 t surge bin. The powerplant Coal-handling System will then route the low-sulphur coal to the silos or to the storage areas.



## 8.2.8

### Coal Sampling

Throughout the coal-mining and handling operations described in the preceding sections, coal-sampling is used to monitor the quality of the coal. This is necessary to ensure the supply of coal of consistent quality to the powerplant, efficient use of the resource, and to allow efficient control in all areas of the project. Sulphur content, as well as HHV/ash, is analysed to assist in maintaining a mean sulphur level in powerplant fuel which provides SO<sub>2</sub> emission levels within the predicted range. The coal-sampling techniques employed in the mine area are described in Section 7.5, "Fuel Quality Control". Sampling of coal in the materials-handling system takes place in each of the coal-handling operations described in Section 8.2.3. The locations, as shown on Figure 8-1, are: (1) before blending; (2) after reclaiming in the mine operations; and (3) before silo-filling in the powerplant.

Standard and special analyses of the samples from the various stages will be carried out in on-site laboratories. The results will be used to monitor the operation. The measurement of sulphur in the coal will be also carried out by standard methods. However, a sulphur monitor with rapid readout is being developed and is expected to be installed for testing in the near future. This type of device would be included in the Sampling System in the detailed engineering phase, should it prove effective.

The installations are described below.

#### 8.2.8.1

##### Belt-Sampling - Mine

Automatic samplers, one on each of two conveyor belts (C8A, 8B), are installed in the Sample and Transfer House located between the Screening and Crushing Plant and the Blending/Storage Yard. These samplers monitor the quality of coal going into the blending/storage piles. A second installation located in the Sampling and Transfer House on the Overland Conveyor monitors the quality of coal being delivered to the powerplant.

Each of these installations is interlocked with weigh scales, which allows the samples to be taken at predetermined intervals. This also enables the weighted average quality of coal in the blending piles, or shipped to the powerplant, to be determined.

The information provides feedback to mine operations to check predictions and to adjust the mining schedule if required.

The variation in values obtained from these two installations checks the efficiency of the blending operations. In addition, provision is made for the installation of continuous ash monitors, which give a rapid check of the ash content of the coal. Because of the linear relationship between ash and heating value, a quick check on the heating value of the coal is therefore possible. This readout can then be integrated to show the aggregate value of the coal in the stockpile or of the coal shipped to the powerplant in a given period. The heating value of the coal being delivered to the powerplant is automatically relayed to the powerplant.

#### 8.2.8.2 Belt-Sampling - Powerplant

Sampling installations similar to those described in 8.2.8.1 are employed. At the powerplant, coal-sampling will be carried out for plant operation, for plant performance assessment, and for monitoring in relation to stack emission data.

### 8.3 WASTE-HANDLING

#### 8.3.1 Waste-handling System Requirements

This section describes the material-handling equipment and methods required to transport waste materials from the pit to their respective disposal areas and to construct the waste dumps to meet the requirements of the mining plan and production schedule presented in Section 5. The schedule shows that the total volume of waste to be handled over the life of the mine is  $426.8 \times 10^6$  bank  $m^3$ . It is planned to dispose of  $418 \times 10^6$  bank  $m^3$  in the waste dumps; the remainder will be used for road construction, etc. The peak year for waste production will be Year 11, when  $18.25 \times 10^6$  bank  $m^3$  will be handled.

#### 8.3.2 Design Criteria

The basic design criteria described in Section 8.2.2, "Coal-handling - Design Criteria", will apply to the waste-handling and conveying systems. The bulk density for conveyor and equipment capacity calculations is  $1,600 \text{ kg}/m^3$  for the waste materials. For other waste material parameters refer to Section 5.2.5. For ash-handling, the bulk density of loose ash is about  $800 \text{ kg}/m^3$  and of compacted ash about  $1,280 \text{ kg}/m^3$ .

##### 8.3.2.1 Design Features

The design features noted in Section 8.2.2, "Coal-handling - Design Criteria", are also incorporated in the design of the Waste-handling System. The clay-handling system is carefully designed to account for the volumes of wet and sticky materials. Features of this system minimize the handling of the material by eliminating surge hoppers and storage bins, reducing the number of transfer points, employing vertical drops at transfer points where possible, and avoiding two-way chutes, etc.

### 8.3.3 Waste-handling System - Description

The project Waste-handling System can be divided into two separate areas, as shown on Figure 8-1. They are:

#### 1. Mine Waste Disposal

Mine waste disposal consists of an in-pit handling system and a dump construction system to handle the mine waste materials. The latter will consist of two identical systems initially installed in the Houth Meadows Dump, with one of them being relocated to the Medicine Creek Dump in Year 15.

#### 2. Ash Disposal

This consists of two identical systems to handle the fly-ash and bottom-ash materials from the powerplant for disposal in Medicine Creek.

Ultimately, Medicine Creek will receive both mine waste and ash. Careful scheduling of the dumps' construction will ensure that each system can operate effectively without affecting the other.

These separate and independent operations are described below.

### 8.3.4 Waste-handling - In-Pit

The In-pit Waste-handling System shown on Figure 8-3 consists of the following:

#### 1. Truck Dump Stations

As described in Section 8.2.4.1, "Coal-handling - Mining", a total of three dump stations are installed. Waste materials, loaded on 154 t rear dump haulage trucks by the 14.5 m<sup>3</sup> hydraulic shovels, are delivered at a peak rate of 5,000 t/h to the designated dump pockets at the dump stations. In-seam waste materials are handled by the 77-t trucks and 10.7 m<sup>3</sup> shovels, as required during mining operations. Each dump pocket is designed to handle up to 2,500 t/h. The number of dump

pockets installed at each of the dump stations depends upon the quantities of the different materials to be delivered to each dump station. Each pocket holds three truckloads of material and has a 600 mm square grizzly installed to screen off oversize material.

As shown on Figure 8-2, there are four pockets installed at the first dump station, two for construction materials (M3 and M4) and two for general waste/clay materials (M5 and M6). The second station has two pockets for construction waste (M11 and M12), one for general waste, and the third has one for construction materials (M13). The pocket at the third dump station will be relocated from the first station. Each of these pockets is identical in design, to allow for the handling of all materials.

Separate dump pockets (M7 and M14), as shown on Figure 8-3, with a capacity of one truckload of material, are installed at the first and second dump stations, to handle wet clay. This pocket is located directly over the general waste/clay conveyor, allowing the transfer of material to the conveyor through an apron feeder, and eliminating handling through a crusher. A grizzly will screen off oversize materials, which will be disposed of by front-end loader and truck.

Further testing on this wet clay is required before final design of the Clay-handling System.

## 2. Primary Crushing

Waste materials are reclaimed from each dump pocket by a hydraulic reciprocating feeder at a peak rate of 2,500 t/h. Two feeders are required at any time to handle the peak tonnage of a given waste material, i.e. construction grade or general waste/clay. The feeder delivers the waste to a vibrating screen, which removes the -200 mm material and feeds it to a 1,400 mm-wide transfer conveyor below. The oversize material is crushed to -200 mm by an impact crusher, then passes to the Transfer Conveyor for delivery to the appropriate mine waste conveyor.

A preliminary selection of an impact crusher has been made. This crusher has the ability to handle the run-of-mine materials in Hat Creek, although further tests are required, especially for the clay materials. The crusher can be fitted with heated impact surfaces which would release wet clay. This feature can be easily retrofitted if necessary. Other types of crushers studied are discussed in the Simon-Carves' report 1979.

Although the crushers are designated for specific materials, their ability to handle other materials allows added flexibility in the

system - for example, coal and low-grade coal routed through the impact crusher and delivered to the coal belt by use of a two-way chute on the Transfer Conveyor. Figure 8-3 shows this arrangement.

### 3. Waste Conveyors

The In-pit Waste Conveying System is designed to handle the two types of waste. Two conveyors, each with 1,400 mm-wide steel cord belt, will be installed. The first, designated "Waste Conveyor" (M8B), handles only construction-grade materials; and the other, designated "Waste/Clay" (M8C), handles general mine waste/clay and is equipped to handle wet clays. Table 8-5 gives details of the conveyors.

The Waste Conveyor, ultimately three flights long (M8B, M9B, and M10B) to follow the mine development, receives the construction-grade material from the transfer conveyors and transports it at up to 5,000 t/h to the Drive and Transfer House. Here the material is routed to a pair of waste bins, adjacent to the low-grade coal bins, by a 1,400 mm-wide transfer conveyor (W1). A two-way chute ensures equal distribution of material into the bins. A pair of apron feeders (W2A and 2B) discharge the waste from the bins to a 1,400 mm-wide transfer conveyor (W3), which feeds it to one of two overland conveyors (H01 and H02). A two-way chute determines which conveyor carries the material to Houth Meadows, or, in later years, to Medicine Creek. The waste bins incorporate truck-loading facilities for emergency use and surge if the dump waste-conveying systems are inoperative, and also provide a supply of construction-grade materials for road building or other uses.

The Waste/Clay Conveyor is only two flights long (M8C and M9C). A study of material distribution indicates that a third flight is not required. The general waste materials received from the Transfer Conveyor, or, in the case of wet clay from the apron feeder at dump pocket M7 or M13, are delivered to the surface, bypassing the Drive and Transfer House, and are delivered to either one of the overland waste conveyors to Houth Meadows. A moving-head pulley on the Waste/Clay Conveyor allows selection of the appropriate conveyor to Houth Meadows.

Mine conveyors (M8D and M9D), as shown on Figure 8-3, provide some flexibility and back-up in emergencies. These conveyors, primarily handling low-grade coal, as described in Section 8.2.6, also handle construction-grade material as well as coal when required.

The Waste-handling System must be able to dispose of both types of waste materials to suit the method and sequence of construction of the dumps.

The retaining embankment must be constructed using only sand and gravel. The section of the dump upstream from the embankment will be used to dispose of the general waste/clay materials.

The dumps will be constructed in 35-m lifts with a system which consists of conveyors and spreaders. Two systems, each building a 35-m lift, will be installed initially at Houth Meadows, with one system being relocated to Medicine Creek in Year 15.

Each system will be installed at the upstream end of the dump and will progress downstream to the retaining embankment. After each lift is completed, the system will be dismantled and reassembled at the upstream end of the dump to begin another lift. A pictorial layout of the Houth Meadows Waste-handling System is shown on Figure 8-7; the components are described below. Section 5.5 describes the method of construction and the development sequence of the dump and its retaining embankment.

#### 1. Conveyors

The initial development of Houth Meadows Waste Dump will be carried out by two independent systems. Each of the two systems consists of three types of conveyor, i.e. permanent overland, transfer, and shiftable. Table 8-5 lists the conveyors. Because of the capacity and high belt tensions, the conveyors are equipped with a steel-cord belt.

Although similar in design and construction, the 1,400 mm-wide conveyors have special features necessary for their particular function. For example, the Shiftable Conveyor is complete with shifting rails to facilitate moving the conveyor line on the dump. Drive stations on the transfer and shiftable conveyors are mounted on pontoons for easy moving.

Material from the mine, i.e. construction waste or waste/clay, is delivered to one of the two overland permanent conveyors (H01 or H02), either from the waste bins or direct from the mine in the case of clay materials. The material is then fed to the Transfer Conveyor (HT1 and HT2), and then to the Shiftable Conveyor (HS1 and HS2) via a short portable conveyor. A travelling-belt tripper transfers the material to the spreader.

The position of the system on the dump determines which material is required, i.e. construction waste for embankment construction or general waste for other areas.

## 2. Spreaders

Each of the two systems incorporates a crawler-mounted spreader to place the waste materials.

The specifications are as follows:

Length of loading boom	- 40 m
Length of discharge boom	- 40 m
Belt width	- 1,400 mm
Belt speed	- 4.5 m/s
Discharge height	- 18 m
Capacity	- 5,000 t/h.

As shown in Figure 8-7, the spreader, receiving material via the belt tripper, dumps the waste first in a 20-m lift below and ahead of the Shiftable Conveyor, and then in a 15-m lift above and behind the conveyor. The spreader and Shiftable Conveyor, after completing a cycle, are moved 50 m down the dump towards the retaining embankment to begin another pass. A dozer provides the necessary back-up to the spreader for levelling and clean-up. One of the spreaders will also be relocated to Medicine Creek in Year 15. A front-end loader and 32-t truck fleet are used to deliver waste to areas beyond the reach of the spreader.



### 8.3.6

#### Waste-handling - Medicine Creek

It is planned to begin using Medicine Creek for waste disposal in Year 15. One of the two conveyor and spreader systems will be relocated from Houth Meadows; additional overland conveyors will be required. The route selected for the Overland Conveyors (M01 to M05) from the mine mouth will be parallel to the Overland Coal Conveyor C15, and will continue to a transfer station at the Northern edge of Medicine Creek. The system of Transfer Conveyors (MT1 and MT2) and Shiftable Conveyor (MS1) and spreader extends from this Transfer House into the dump area.

The method of operation of the system and dump development sequence will be the same as for Houth Meadows. Table 8-6 gives details of the conveyors.

The Ash-handling System, as described in Section 8.3.6, will be in operation in mid-Medicine Creek at all times. Delivery of waste materials to Medicine Creek will be scheduled to ensure that the disposal of ash will not be affected. Figure 5-20 shows the dump with the waste and ash interface.

### 8.3.7

#### Ash-handling - Medicine Creek

Close attention has been paid to the design of the Hat Creek Ash-handling and Disposal System due to the large quantities involved, because reliability of the entire system is of the utmost importance for continuous power production. The system caters for variations in ash production under all conditions of the specified operating regime, such as the unusual amounts of bottom-ash which could form at times.

For ash systems, environmental impacts are particularly prominent, and these have been addressed, together with mitigation measures. The adoption of a "dry" disposal scheme reduces the quantity of water required from the Thompson River and uses the storage area more effectively than "wet" ash disposal.

Safe working conditions are vital and will be prescribed during the construction, operation, and maintenance of the system. Economics of operation, including manpower requirements, have been studied to minimize costs.

Provision for loading fly-ash or bottom-ash for sale has not been included, but can be incorporated if and when needed. Provision for possible recovery of fly-ash or bottom-ash from the disposal site is not included.

#### 8.3.7.1 Bottom-ash

The Bottom-ash Removal System is shown on Figures 8-10 and 8-11.

A continuous removal system using a submerged drag-bar conveyor (98) moves the ash from beneath each boiler and discharges it to a cross-belt conveyor (99) and thence to one of two collecting belt conveyors (100A and 100B) which service all four boilers.

The final position and arrangement of this equipment will be established when the boiler is designed.

The Drag-bar Conveyor (98) is driven through a motor-gearbox combination to a round-link-type chain and sprocket assembly at a fixed or variable speed related to boiler load. The design incorporates within the boiler hoppers quenching water sprays, which cool and break up the ash. The hoppers are fitted with shut-off gates.

The ash is further cooled in the Drag-bar Conveyor Trough to an acceptable temperature for handling by the belt conveyors. The water temperature in the trough is controlled by a heat exchanger and recirculating-pump cooling system. A surge tank is incorporated to absorb the excess water during removal cycles of rejects from the coal pulverizers, which are sluiced intermittently to the Drag-bar Conveyor Trough.

The bottom-ash and pulverizer rejects move up the inclined section of the conveyor, allowing the quenching water to drain off and eliminating the need for dewatering bins.

Provision for an ash crusher, between the Drag-bar Conveyor (98) and the Unit Cross-belt Conveyor (99), would be included, should it be established that this would reduce compacting effort at the disposal site.

During normal operation only one of two collecting belt conveyors (100A and 100B) will operate; start up and transfer to the standby conveyor is automatic.

Capacities are based on bottom-ash at 40% water content. Unit cross-belt capacity includes 20% surge capacity and collecting belt conveyors include 10% surge capacity.

#### 8.3.7.2 Fly-ash

The Fly-ash Removal System is shown on Figure 8-12.

Reliability at high elevations necessitates a pressure system for fly-ash removal.

Fly-ash is released from collecting hoppers by air lock valves and is pneumatically conveyed in pipes. Fly-ash discharges to one of two storage silos whose volume depends upon the selection of either an intermittent or a continuous removal system.

Each silo is equipped with two conditioner/unloaders to discharge fly-ash in a dampened state to the transport conveyors (101A and 101B).

#### 8.3.7.3 Economiser and Airheater Ash

Ash collected from the economiser hoppers and air pre-heater hoppers is transported by the Fly-ash Pressure System to the two storage silos.

As a possibility exists that large pieces of ash may form in the economiser from agglomeration, there will be provision to fit the hoppers with grizzlies to prevent blockage.

#### 8.3.7.4

#### Transportation of Ash to Disposal Area

Two single-flight belt conveyors (101A and 101B) transport both bottom-ash and fly-ash from the powerplant to the North side of the disposal area in mid-Medicine Creek Valley. This system is shown on Figures 8-10, 8-12, and 8-13.

To minimise dust problems, dewatered bottom-ash is deposited over the fly-ash on the conveyors, although it is necessary periodically to load bottom-ash and fly-ash on separate conveyors when building drainage courses within the ash disposal pile.

As they are downhill conveyors, the loaded ash transportation conveyors will feed power back to the plant. A reliable braking system is provided.

Typically, the Ash Transportation System will handle about 10,000 t/d of ash from four units operating at full load when burning performance coal.

One transportation conveyor runs continuously, carrying bottom-ash, and the other conveyor is on standby. For five hours in each shift, fly-ash is discharged from the storage silos to the Transportation Conveyor upstream of the bottom-ash loading point, allowing bottom-ash to cover the fly-ash. During the time that only bottom-ash is sent to the disposal area, this is spread and compacted in the drainage layer for the succeeding mixture of fly-ash and bottom-ash.

The control station for the ash-handling systems is located in the South end of the Powerhouse at ground level, with local/remote controls for cross-belt conveyors at each unit. Bicolour signal lights operated in conjunction with the discharge gates from the fly-ash silos indicate to the operators at Medicine Creek what material is being loaded to the Transportation Conveyor, which is fitted with emergency stop controls at the discharge end.

The mid-Medicine Creek Valley disposal site will be prepared by removal of all vegetation and topsoil.

Two Shiftable Conveyors (102A and 102B) are used to deliver the ash from the transportation conveyors to the required location at the disposal site. This will initially be at the base of the reservoir dam at the East end of mid-Medicine Creek Valley, moving Westwards.

Two mobile conveyors (103A and 103B), two shiftable stackers (104A and 104B), and two rubber-tired dozers distribute the ash, which is deposited and compacted in layers of approximately 300 mm thickness. One shiftable conveyor, one mobile conveyor, and one shiftable stacker will be in service while the second of these pieces of equipment will either be on standby or will be moving to a new location on the disposal site.

Most of the ash is placed and compacted as a mixture of fly-ash and bottom-ash, but drainage courses of bottom-ash are laid at specified elevations to promote proper drainage within the pile. It is possible that during Winter months, less compaction will be achieved than during the warmer season.

#### 8.3.7.5 Ash Disposal, Pile Reclamation, Drainage, and Stability

Reclamation of the Ash Disposal Pile will be a continuous process. Figure 8-14 shows an early stage in the development of the ash disposal area and its reclamation.

As soon as the final elevation has been reached in each section, approximately 600 mm of topsoil will be spread and seeded to prevent erosion. This will occur following Year 3, Year 6, and Year 15 of powerplant operation, and is environmentally advantageous, as reclamation of disturbed land areas reduces erosion, seepage, and fugitive dust emissions.

Removal of all vegetation and topsoil from the ash disposal area will leave a stripped surface of glacial till or other similarly impermeable surface.

Lined drainage courses are provided at the bottom and sides of the disposal area in addition to those within the pile, to prevent accumulation of water and consequential pile instability.

The finished surface of the pile is sloped a minimum of 1% to the West and South. During the initial 15 years of powerplant operation, precipitation and seepage from the make-up water reservoir will be collected behind a berm located just downstream of the ash-pile toe. This wastewater will then be pumped to a runoff holding basin sited North of the waste pile.

Rainfall runoff from the powerplant site and the associated coal storage area is collected in drainage ditches and feeds by gravity to the holding basin, where it is available for ash-dust suppression.

The lower slope of the ash disposal area is sloped 5% as shown on Figure 8-13. Ash and mine waste volumes produced may also be higher than anticipated, but the capacity of the disposal area can be increased by raising the mine waste embankment and filling the area up to the minimum slope of 1% if required, depending upon volumes required by less densely compacted ash during freezing conditions.

#### 8.4 ELECTRICAL POWER SUPPLY

##### 8.4.1 Mine - Coal, Waste, and Ash-handling

The mine coal and waste conveyors, Coal Screening and Crushing Scheme, Coal-blending and Reclaim System, overland conveyor intermediate drive motors, and Ash-handling System, will all be tapped off the 60 kV overhead ring main system supplied from the switchyard at the powerplant. One overhead 60 kV line runs from the switchyard down a common corridor with the Overland Conveyor to the Coal Blending Area, where it turns South down the waste conveyor route to Medicine Creek. A second 60 kV line runs down the ash conveyor route, turning West along the North edge of Medicine Creek, to link up with the first 60 kV line to complete the ring. In this way, all areas of the Materials-handling System have two independent and physically segregated alternative supplies.

##### 8.4.2 Powerplant - Coal-handling

The powerplant Coal-handling System and the drive motors at the delivery end of the Third Overland Conveyor are supplied from the generating station 6.9 kV station auxiliary boards.

8.5

RECOMMENDATIONS FOR FUTURE TESTWORK

8.5.1

Crushing and General Characteristics of Run-of-Mine  
Materials and Blended Coal

Bulk samples representative of the various run-of-mine materials must be obtained for testing. However, some material samples will not be available until after mining commences, as they will derive from lower levels of the pit.

The following tests are recommended:

- (1) A run-of-mine size analysis, and a size analysis for each material after crushing and handling operations, using different crushers;
- (2) Tests to determine the breaking characteristics of the better coals; specifically, to obtain answers to such questions as: If the better coals are harder than the waste materials, is beneficiation by selective crushing and screening feasible? Would a Bradford Breaker reject good coal along with petrified wood and clay?
- (3) Tests to identify problems connected with petrified wood to obtain answers to questions such as: Could impactor crushers allow scalping off this material after being subjected to primary crushing? Is the material intrinsically so hard that damage may result by using simpler types of crushers like the "Wing" crusher? Could a Bradford Breaker reject this material from say 200 x 50 mm raw coal at the secondary crushing stage?
- (4) Tests to indicate practical methods for dealing with claystone waste, specifically in connection with moisture content, and crushing and handling characteristics when mined in conditions anticipated;
- (5) Tests to determine the basic material parameters to aid in the design and selection of handling equipment and silos, such parameters to include bulk density factors, angle of repose and surcharge, flowability, and shearing.



### 8.5.2 Borecore Test Program

Since bulk samples can only be obtained from many areas after mining has advanced, it will be necessary to obtain data from suitable large-diameter (200 mm) drill cores. In many cases they should help to answer the above questions, subject only to final design stage confirmation.

The program must first establish the applicability and technique of the method by comparison with data from adjacent bulk trenches.

It is not anticipated that a large number of these drill cores will be required. (Their situation can be determined from existing small-diameter core results, to ensure that the complete range of materials is sampled.) Due to the thickness of the measures, each core would produce a significant sample weight.

- (1) Dry tumbling tests should be performed to establish the raw coal size consist of coal zones which have not been sampled.
- (2) Samples of all materials should be obtained for practical classification by crushing and handling equipment manufacturers.

### 8.5.3 Crushing Tests

There are no standard test procedures, since each type of crusher makes use of different characteristics. Specific requirements should be determined by consultation with each crusher manufacturer. The following types of crusher will be considered:

Bradford Breakers;  
Siebra Screen/Crusher;  
Impactors;  
Roll Crusher;  
Hammermills;  
Clay Shredders.

Specific attention should be paid to the characteristics of the 200 mm x 50 mm fraction after primary breaking at 200 mm.

#### 8.5.4 Handling Characteristics

- (1) A series of 500 mm x 0 coal qualities should be tested at various surface-moisture contents between 3% and 10%. This should enable the plant designers to project chute angles for the coarser fractions;
- (2) A series of 13 mm x 0 coal qualities should be similarly tested;
- (3) Clay samples must be submitted to equipment manufacturers.

#### 8.5.5 Screening Tests

Specific requirements for a detailed test program for the screening of the various materials will be determined by consultation with screen manufacturers.

The following types of screens will be considered: roller (self-cleaning type), vibrating (woven wire, rod), probability, disc., etc.

Special attention will be paid to the handling of wet fines and sticky materials.

TABLE 8-1

IN-PIT CRUSHING PLANT - TRANSFER CONVEYORS

Conveyor	Length m	Lift m	Capacity t/h	Speed	Installed hp	Year Installed
<u>Dump Station No. 1</u>						
Coal Transfer M1	47	6	1,600	2.5	175	-1
Coal Transfer M2	62	7	1,600	2.5	200	-1
Waste Transfer M3	47	6	2,500	2.5	300	1
Waste Transfer M4 <sup>1</sup>	47	6	2,500	2.5	300	1
Waste/Clay						
Transfer M5	47	6	2,500	2.5	300	1
Waste/Clay						
Transfer M6	47	6	2,500	2.5	300	1
<u>Dump Station No. 2</u>						
Coal Transfer M1 <sup>2</sup>	47	6	1,600	2.5	175	8
Coal Transfer M9	62	7	1,600	2.5	200	8
Waste Transfer M11 <sup>1</sup>	47	7	2,500	2.5	300	8
Waste Transfer M12	47	6	2,500	2.5	300	8
Waste/Clay						
Transfer M13	47	6	2,500	2.5	300	8
<u>Dump Station No. 3</u>						
Coal Transfer M1 <sup>2</sup>	47	6	1,600	2.5	175	20
Coal Transfer M9 <sup>2</sup>	62	7	1,600	2.5	200	20
Waste Transfer M4 <sup>1,2</sup>	47	6	2,500	2.5	300	20

<sup>1</sup> Handles low-grade coal

<sup>2</sup> Relocated from Dump Stations No. 1 and No. 2

Sources: Simon-Carves of Canada Ltd.  
B.C. Hydro Thermal Division

TABLE 8-2

IN-PIT INCLINE - COAL AND WASTE CONVEYORS

Conveyor	Length m	Lift m	Capacity t/h	Installed Power hp	Year Installed
<u>Dump Station No. 1</u>					
Coal M8A	500	45	3,200	1,000	-1
Waste M8B	500	45	5,000	1,400	1
Waste M8C	500	45	5,000	1,400	1
Low-grade Coal M8D	500	45	5,000	1,400	1
<u>Dump Station No. 2</u>					
Coal M9A	400	75	3,200	1,400	8
Waste M9B	400	75	5,000	2,000	8
Waste M9C	400	75	5,000	2,000	8
Low-grade Coal M9D	400	75	5,000	2,000	8
<u>Dump Station No. 3</u>					
Coal M10A	600	90	5,000	1,600	20
Waste M10B	600	90	5,000	2,400	20

Note: All conveyors 1,400 mm wide and 4.5 m/s

Source: B.C. Hydro Thermal Division

TABLE 8-3

## CRUSHING, STACKING RECLAIMING, AND DELIVERY CONVEYORS

Conveyor	Length m	Lift m	Capacity t/h	Speed m/s	Installed hp
<u>Crushing</u>					
Bypass C1 <sup>1</sup>	26	4	3,200	4.5	150
Transfer C2	197	24	3,200	4.5	700
Screen Feed C4A	121	25	1,000	2.5	200
Screen Feed C4B	116	25	1,000	2.5	200
Screen Feed C4C	116	25	1,000	2.5	200
Screen Feed C4D	121	25	1,000	2.5	200
Product C7A	86	7	3,200	4.5	250
Product C7B	112	7	3,200	4.5	250
Product C8A	127	11	3,200	4.5	350
Product C8B	127	11	3,200	4.5	350
Product C9A	187	34	3,200	4.5	700
Product C9B	183	34	3,200	4.5	700
<u>Stacking and Reclaiming</u>					
Transfer C10	135	6	3,200	4.5	200
Stacking C11	670	10	3,200	4.2	600
Reclaim Bypass C12	670	10	3,000	4.2	600
Reclaim C13	670	10	3,000	4.2	600
Collecting C14	135	10	3,000	4.2	250
<u>Delivery</u>					
Overland C15	1,000	80	3,000	4.2	1,500
Overland C16	1,100	245	3,000	4.2	3,200
Overland C17	1,850	165	3,000	4.2	3,000

Note: All conveyors are 1,400 mm wide, except as noted

<sup>1</sup> This conveyor is 1,800 mm wide, 2.6 m/s

Source: Simon-Carves of Canada Ltd.

B.C. Hydro Thermal Division

TABLE 8-4

LOW-GRADE COAL - PLANT CONVEYORS

---

---

Conveyor	Length m	Lift m	Capacity t/h	Speed m/s	Installed hp
Transfer LG1	94	23	5,000	4.5	700
Screen Feed LG3A	115	25	1,000	2.5	200
Screen Feed LG3B	115	25	1,000	2.5	200
Rejects LG7	76	6	1,000	2.5	100
Rejects LG8	188	6.5	1,000	2.5	125

---

Note: All conveyors are 1,400 mm wide

Source: Simon-Carves of Canada Ltd.

TABLE 8-5

HOUTH MEADOWS DUMP - WASTE CONVEYORS

Conveyor	Length at Installation m	Lift m	Installed hp	Year Installed
Transfer W1	93	23	700	1
Transfer W3	75	6	300	1
<u>Line No. 1</u>				
<u>EL900</u>				
Overland H01	600	5	600	1
Transfer HT1	1,150	-	1,000	1
Shiftable HS1	900	-	1,200	1
<u>EL970</u>				
Overland H03	700	70	2,000	6
Transfer HT1A	1,250	-	1,000	6
Shiftable HS1A	1,700	-	1,500	6
<u>Line No. 2</u>				
<u>EL935</u>				
Overland H02	900	35	1,500	2
Transfer HT2	1,250	-	1,000	2
Shiftable HS2	1,300	-	1,500	2
<u>EL1005</u>				
Overland H04	700	70	2,000	9
Transfer HT2A	1,250	-	1,000	9
Transfer HT4	900	-	750	9
Shiftable HS2A	1,500	-	1,200	9
<u>EL1040</u>				
Overland H06	900	70	2,400	23
Transfer HT2B	850	-	750	23
Transfer HT6	850	-	1,000	23
Shiftable HS2B	1,600	-	2,000	23

Note: All conveyors on this table are 1,400 mm wide, 5,000 t/h @ 4.5 m/s

Source: B.C. Hydro Thermal Division

TABLE 8-6

MEDICINE CREEK DUMP - WASTE CONVEYORS

Conveyor	Length at Installation	Lift m	Installed hp	Year Installed
Overland M01	100	6	500	15
Overland M02	100	6	500	15
Overland M03	350	30	1,000	15
Overland M04	1,700	120	4,000	15
Overland M05	1,400	140	4,000	15
<u>EL1060</u>				
Transfer MT1	1,600	-145	Regenerative	15
Transfer MT2	1,000	-	1,000	15
Shiftable MS1	500	-	500	15
<u>EL1095</u>				
Transfer MT1A	1,200	-110	Regenerative	18
Transfer MT2A	1,400	-	1,200	18
Shiftable MS1A	500	-	500	18
<u>EL1130</u>				
Transfer MT1B	800	-95	Regenerative	26
Transfer MT2B	1,500	-	1,200	26
Shiftable MS1B	500	-	500	26

Note: All conveyors are 1,400 mm wide, 5,000 t/h @ 4.5 m/s

Source: B.C. Hydro Thermal Division



TABLE 8-7

POWERPLANT COAL-HANDLING CONVEYORS

Conveyor	Length m	Capacity t/h
Receiving (from Overland Conveyor) 1A and 1B	190	3,000
Belt Feeders (Main Transfer House) 2A and 2B	11	2,500
Powerhouse 4A and 4B	356	2,500
Transfer 5A and 5B	154	2,500
Intermediate 6A, 6B, 7A, and 7B	51	400
Belt Feeders (Powerhouse) 8A, 8B, 8C, 8D, 9A, 9B, 9C, and 9D	11	400
Silo 10A, 10B, 11A, 11B, 12A, 12B, 13A, and 13B	51	400
Belt Feeders (Reclaim Hoppers) 14A, 14B, 14C, 14D, 14E, and 14F	6	1,300
Emergency Reclaimer 15A and 15B	180	2,500
Stacker/Reclaimer 16	43	2,500
Excess Discharge Pile 17	15	1,200
Reclaim and Stockout 18	460	2,500
Emergency Reclaim 19A and 19B	160	2,500

- Note: (1) Belt speeds shall not exceed 3.3 m/s on conveyors except the Silo Conveyors (10, 11, 12, and 13) where the belt speed shall not exceed 2.2 m/s.
- (2) The total installed capacities of the motors for the power-plant Coal-handling System is approximately 3,280 kW.

TABLE 8-8

ASH-HANDLING CONVEYORS

Conveyor	Length m	Lift m	Capacity t/h	Speed m/s	Installed hp
Drag-bar Conveyor 98	21	-	90	-	-
Cross-belt Conveyor 99	48	-	127	1.0	8
Collecting-belt Conveyors 100A and 100B	310	-	453	1.5	50
Transport Conveyors 101A and 101B	2,950	-155	851	2.2	200
Shiftable Conveyors 102A and 102B	1,200	varies	851	2.2	300
Mobile Conveyors 103A and 103B	30	-	851	2.2	20
Shiftable Stackers 104A and 104B	36	-	851	2.2	50

PROJECT COAL-HANDLING SYSTEM  
OPERATING REGIME - EXAMPLES OF VARIOUS OPERATING CONDITIONS

Operating Condition	<u>Mine</u>		<u>Powerplant</u>
	Operation 1: Mining Processing Blending	Operation 2: Reclaiming Loading Delivery	Operation 3: Receiving and Handling to Boilers
Normal silo-filling four units at full load. (Power production maximum for current period of production.)	Mine and process coal to build blending pile at a rate of 40,000 t/d. Hourly rate varies to suit mining operation.	Reclaim, load and deliver 2,500 t/h for 18 hours out of 24 from blending pile.	Receive and fill silos for 18 hours out of 24 at a rate of 2,500 t/h.
Normal silo-filling at 70% full load. (Power production 70% for current period of production.)	Mine and process coal to build blending pile at a rate of 28,000 t/d. Hourly (or daily) rate varies to suit mining conditions.	Reclaim, load and deliver 2,500 t/h for 12½ hours out of 24 from blending pile (or 4 hours/shift).	Receive and fill silos for 12½ hours out of 24 at a rate of 2,500 t/h or (4 hours/shift).
Operations 1 and 2 lost temporarily. (Mine and blending, etc.)	Out	Out	Reclaim and fill silos for 18 hours out of 24 from storage at a rate of 2,500 t/h. (Minimum storage about 14 days at full load.)
Operation 3 lost temporarily. (All powerplant production.)	Continue to feed both blending piles until their capacity reached. Then switch, if necessary to waste material moving.	Cease delivery until powerplant calls for coal for silo-filling or storage.	Silo-filling ceases. If auxiliary power is functional silos can be filled and coal can be accepted to storage.
Mine over-producing temporarily.	Continue building blending piles to capacity.	Deliver at rate advised acceptable by powerplant.	Fill silos normally. Excess to powerplant storage.
Operation 2 under-producing temporarily. (Blending, loading and delivering.)	Continue building blending piles to capacity.	Deliver at best rate possible. Restore planned rate as soon as possible.	Fill silos continuously with mine deliveries. Reclaim necessary quantity from storage to supplement.
Operation 1 under-producing temporarily. (Mine)	Restore planned rate as soon as possible. Continue to build blending pile at best rate possible.	Deliver at planned rate until blending piles used.	Continue normally unless shortfall of delivery occurs. Reclaim necessary quantity from storage to supplement.

Operating Condition	<u>Mine</u>		<u>Powerplant</u>
	Operation 1: Mining Processing Blending	Operation 2: Reclaiming Loading Delivery	Operation 3: Receiving and Handling to Boilers
Lower-sulphur coal required for brief MCS operation.	No change.	No immediate change. Plan deliveries based on revised daily instructions from powerplant.	Reclaim lower-sulphur coal from live storage immediately and start filling silos. If necessary continue from dead storage. If necessary call for delivery of lower-sulphur coal from operation 1.
Lower-sulphur coal required for lengthy MCS operation.	Mine and process high-grade coal for delivery to powerplant bypassing operation 2.	If required, can continue to build blending piles with coal routed through low-grade coal facilities at 2,000 t/h.	Receive lower-sulphur coal only from operation 1 to fill silos.
Rebuilding performance coal stockpile at powerplant after major period of non-delivery.	Mine at maximum rate to keep up with operation 2.	Deliver maximum rate powerplant can take from overland conveyor as long as powerplant can accept maximum flow.	Receive coal at maximum overland conveyor capacity (3,000 t/h) continuously. Excess coal to stockpile. Rebuild live and dead storage. Rebuilding live storage on this basis would take about two days even with four units at full load. Rebuilding 14-day dead storage pile would take up to 17 days on this basis.
Rebuilding lower-sulphur stockpiles at powerplant while burning performance coal.	Deliver lower-sulphur coal for six hours out of 24 bypassing operation 2.	Deliver performance coal for 18 hours out of 24.	Performance coal to silos. Lower-sulphur coal to storage.

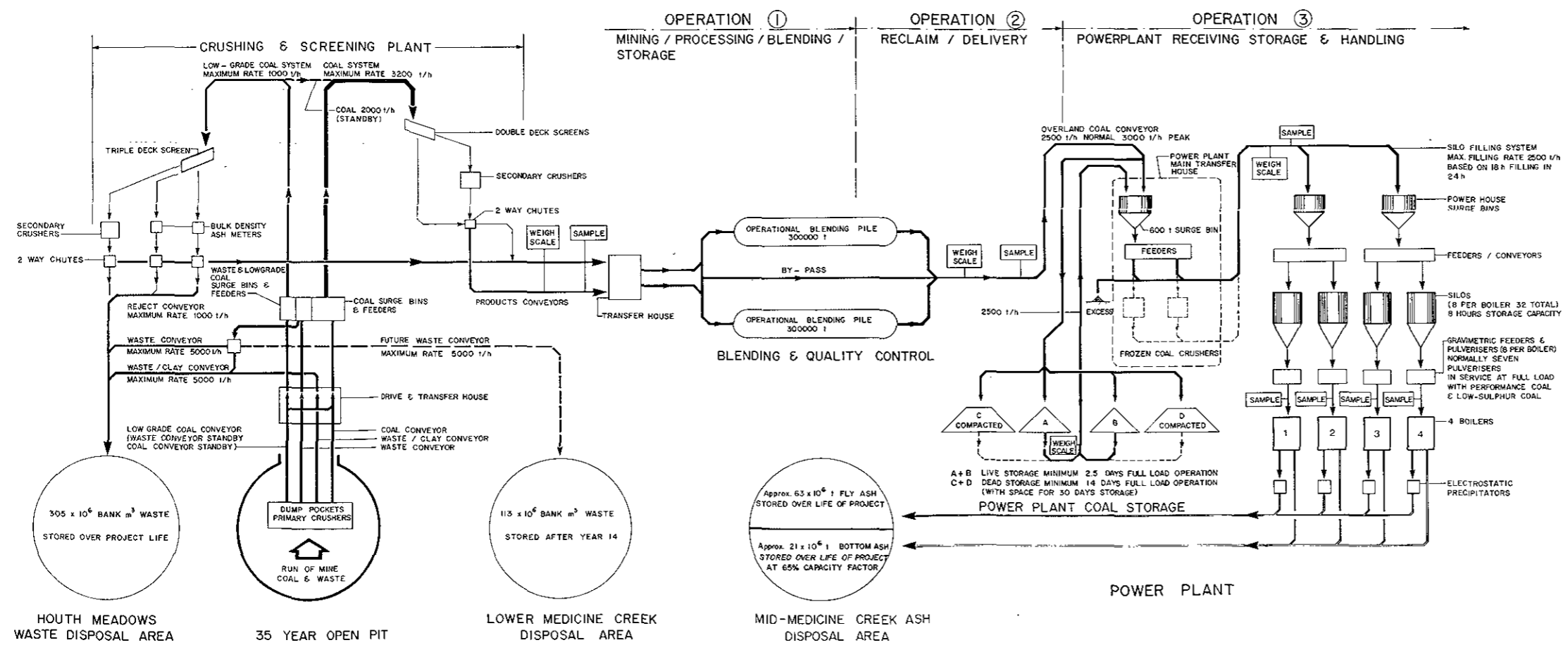

HAT CREEK PROJECT  
**FIGURE 8-1**  
**Overall Project Flow Diagram**

SOURCE: British Columbia Hydro and Power Authority

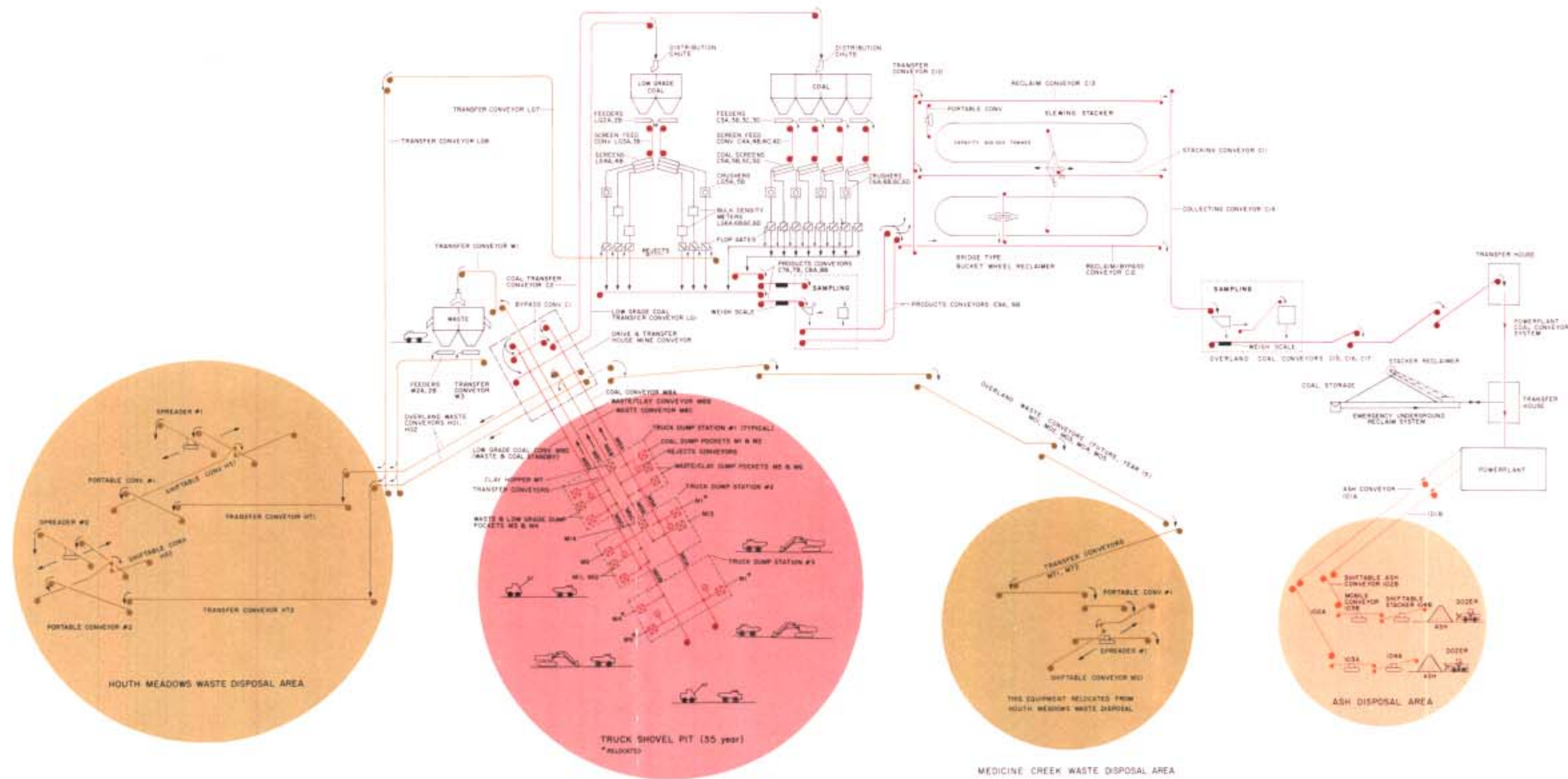

HAT CREEK PROJECT  
 FIGURE 3.6  
 MATERIALS HANDLING SYSTEM  
 FLOW DIAGRAM

SOURCE: Conoco — Moberly Joint Venture (3)

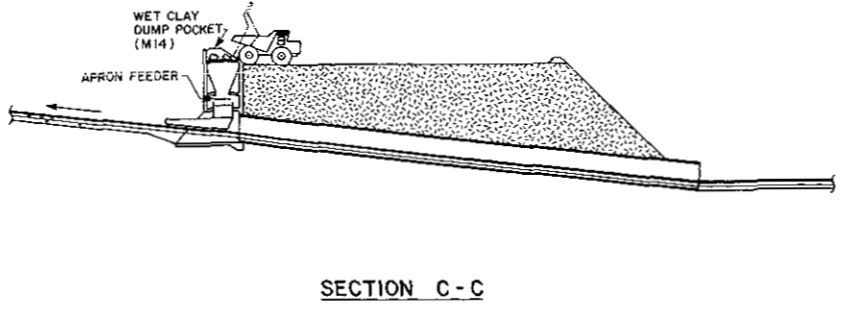
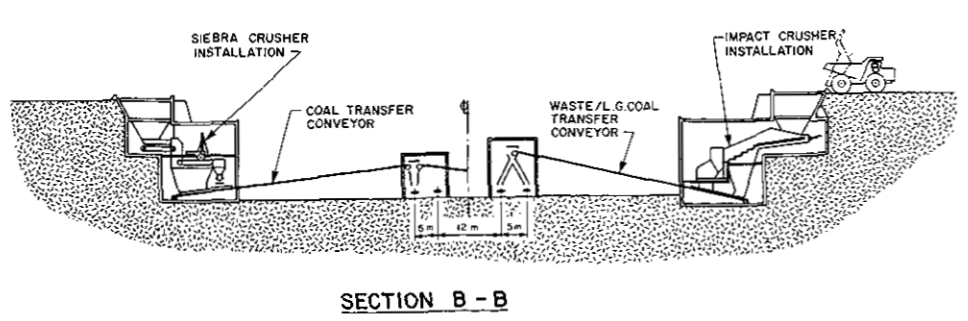
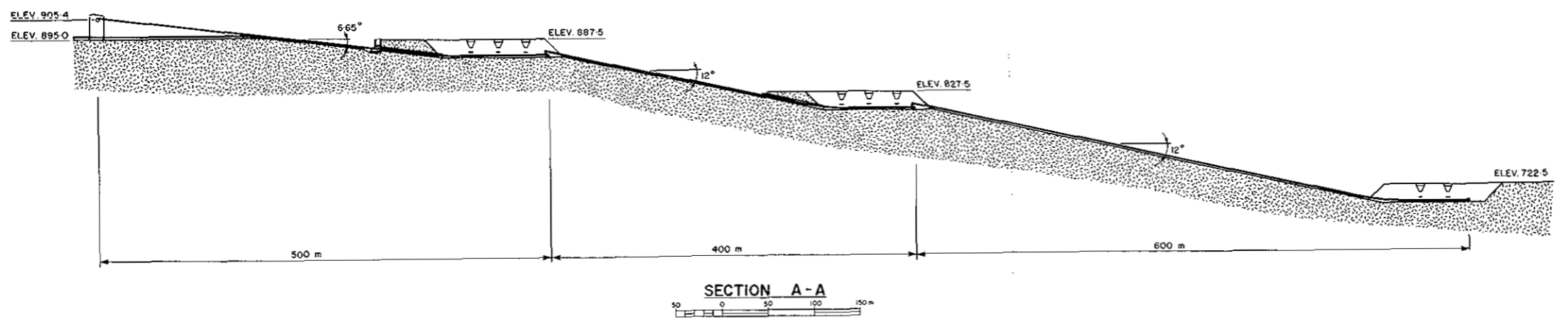
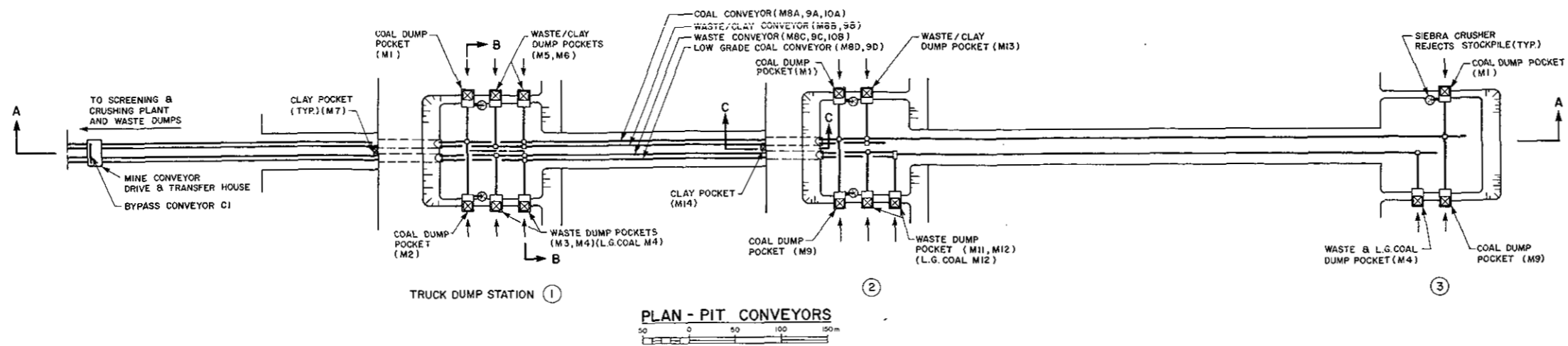

HAT CREEK PROJECT  
**FIGURE 8-3**  
**General Arrangement**  
**Mine Conveyors and**  
**Truck Dump Stations**

SOURCE: Simon-Carves of Canada Ltd.

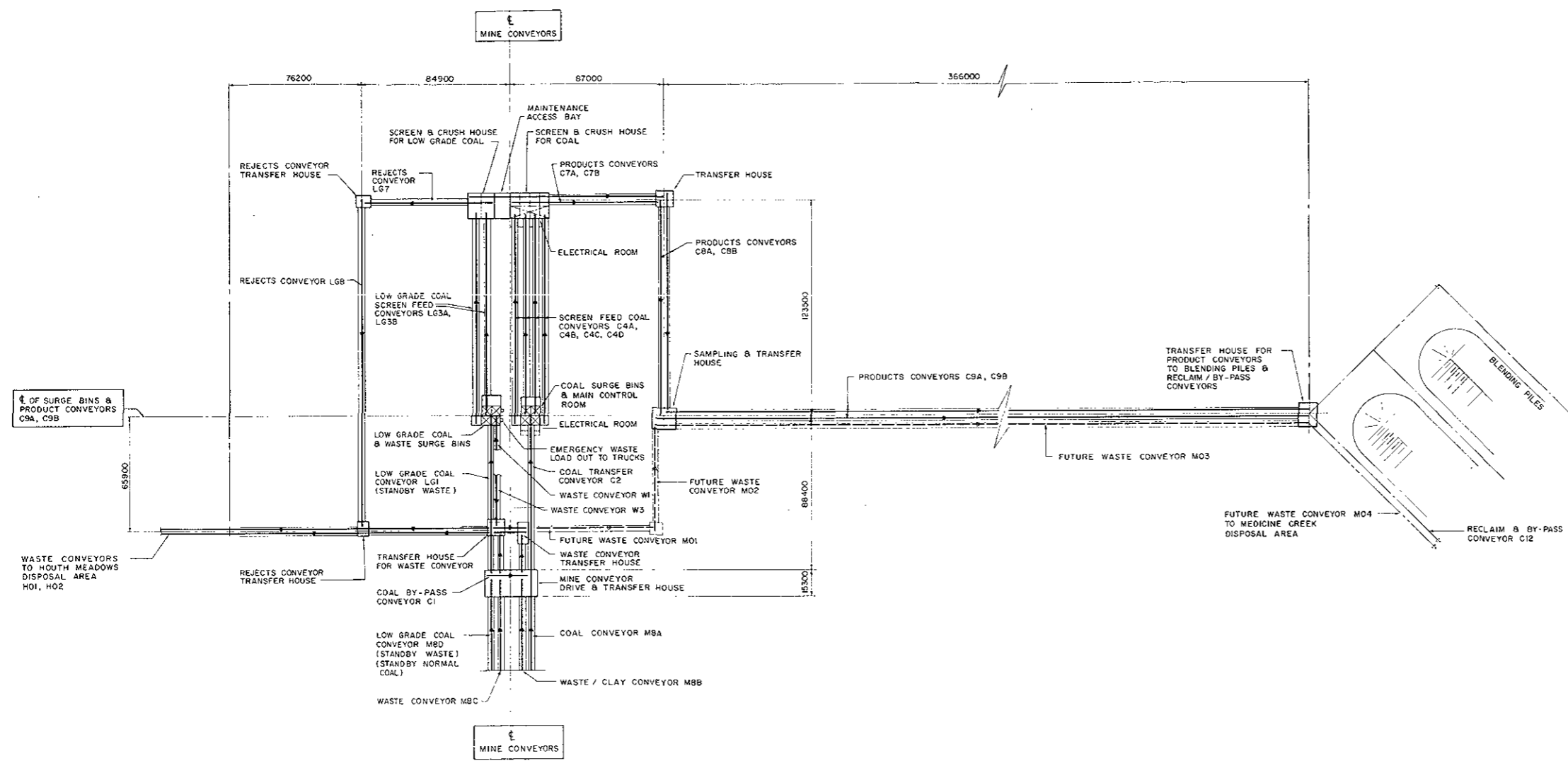

HAT CREEK PROJECT

FIGURE 8-4

**General Arrangement  
Screening and crushing**

SOURCE: Simon-Carves of Canada Ltd.



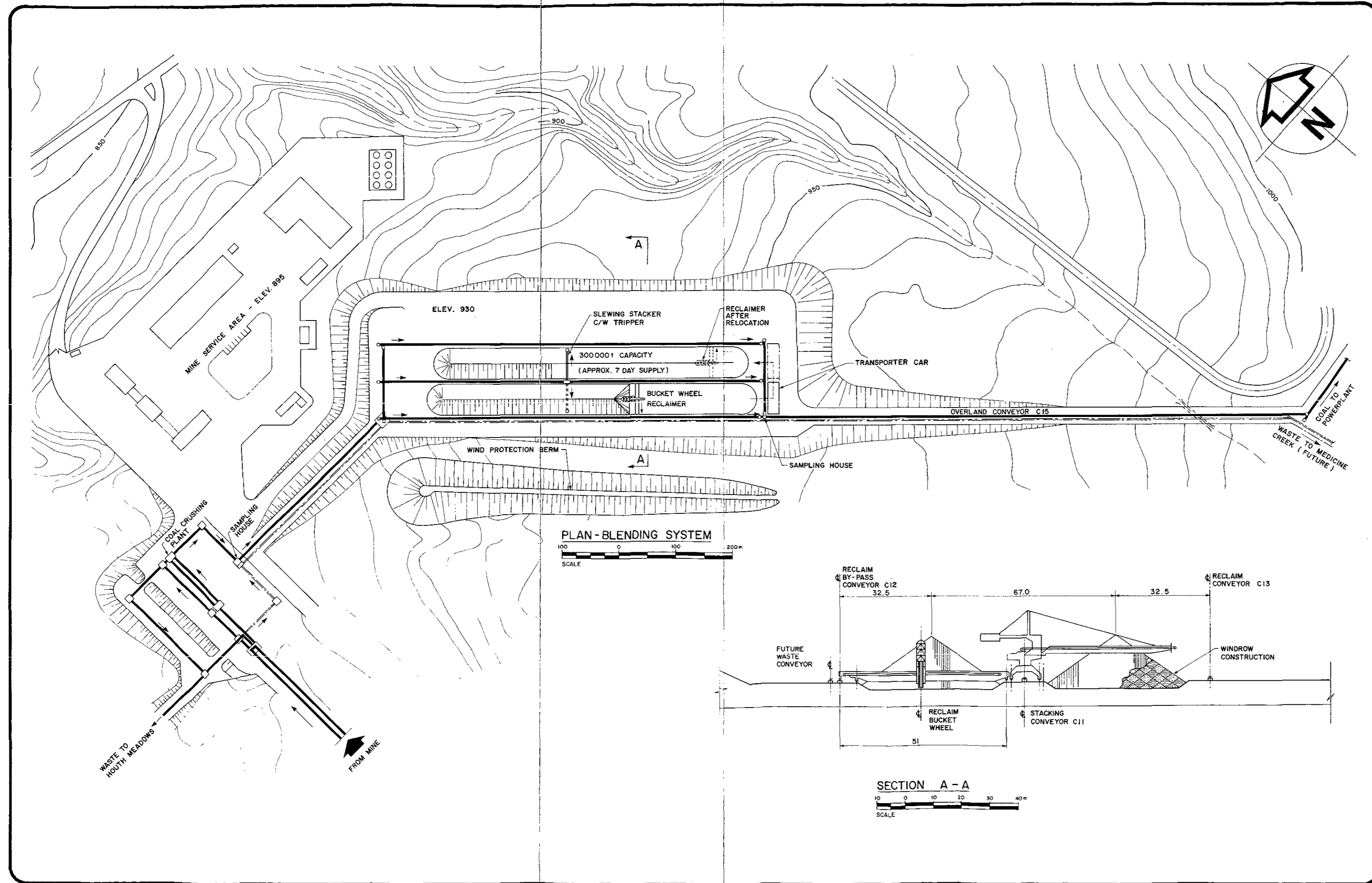

HAT CREEK PROJECT  
**FIGURE 8-5**  
**General Arrangement**  
**Blending / Reclaiming**

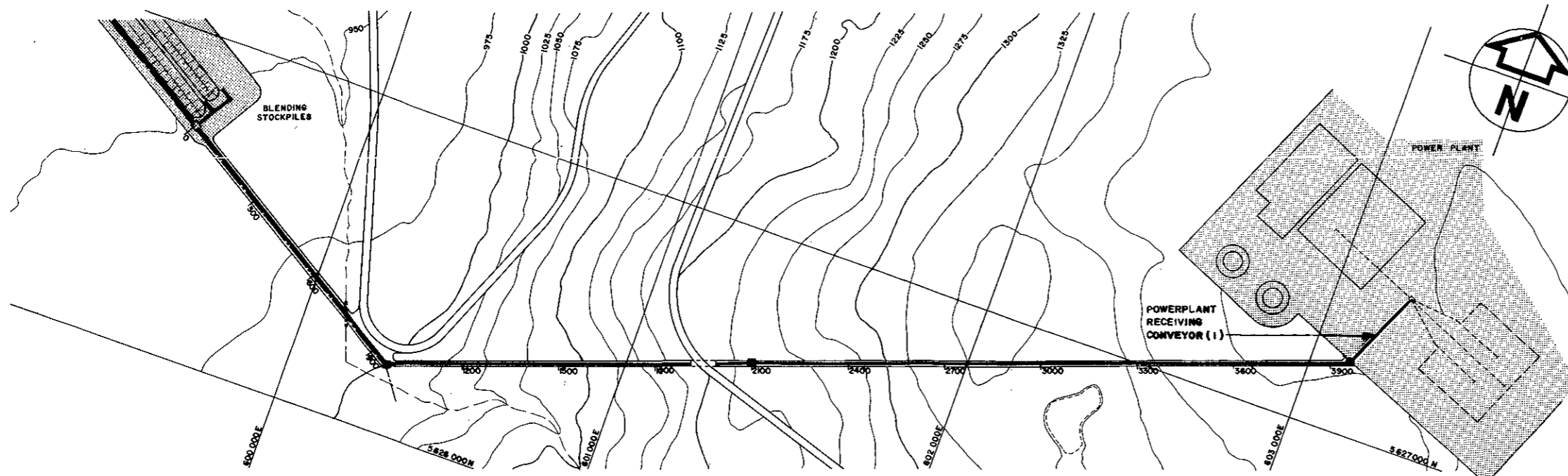

PLAN - OVERLAND COAL CONVEYOR

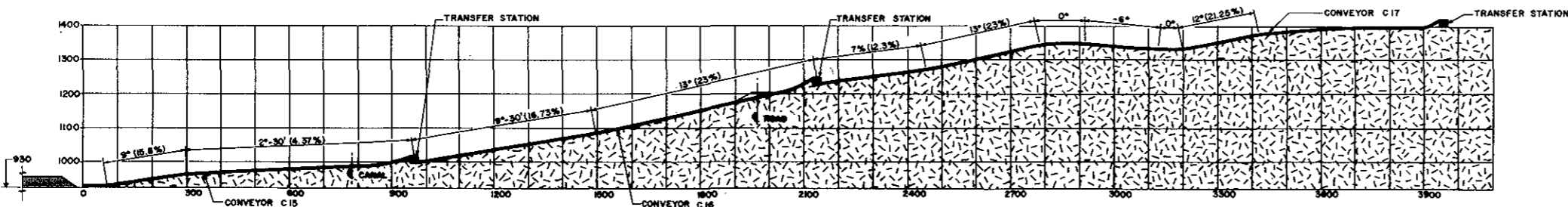

PROFILE - CONVEYOR

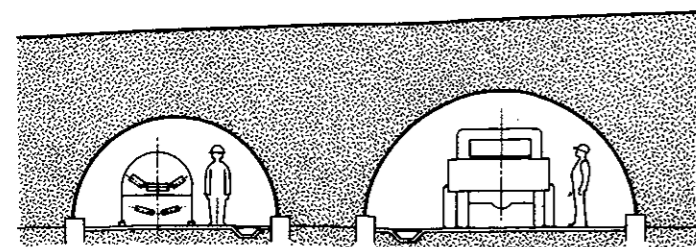

SECTION - HIGHWAY UNDERPASS

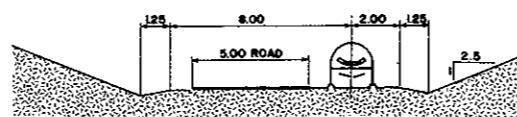

TYPICAL SECTION - CUT

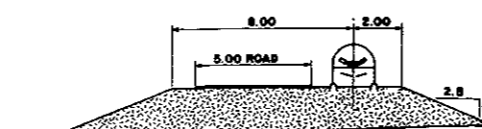

TYPICAL SECTION - FILL

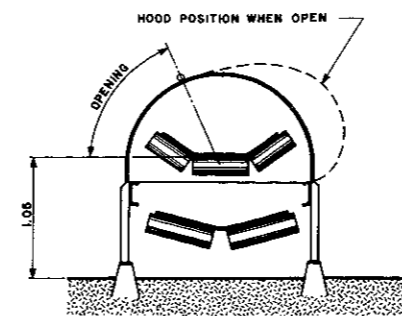

TYPICAL SECTION - COAL CONVEYOR



HAT CREEK PROJECT

FIGURE 8-6

**General Arrangement  
Overland Coal Conveyor**

SOURCE: British Columbia Hydro and Power Authority

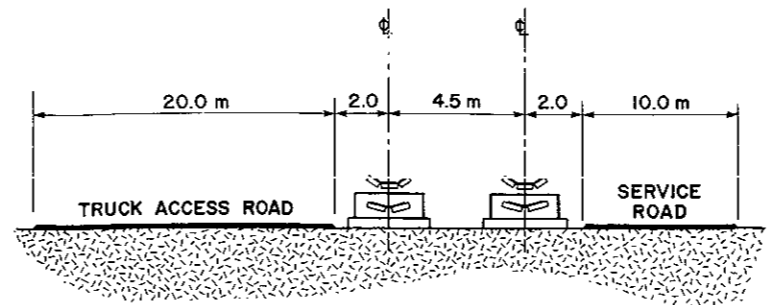
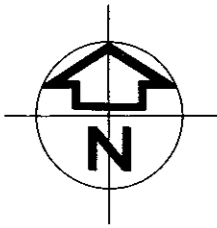

**TYPICAL SECTION**  
OVERLAND CONVEYORS

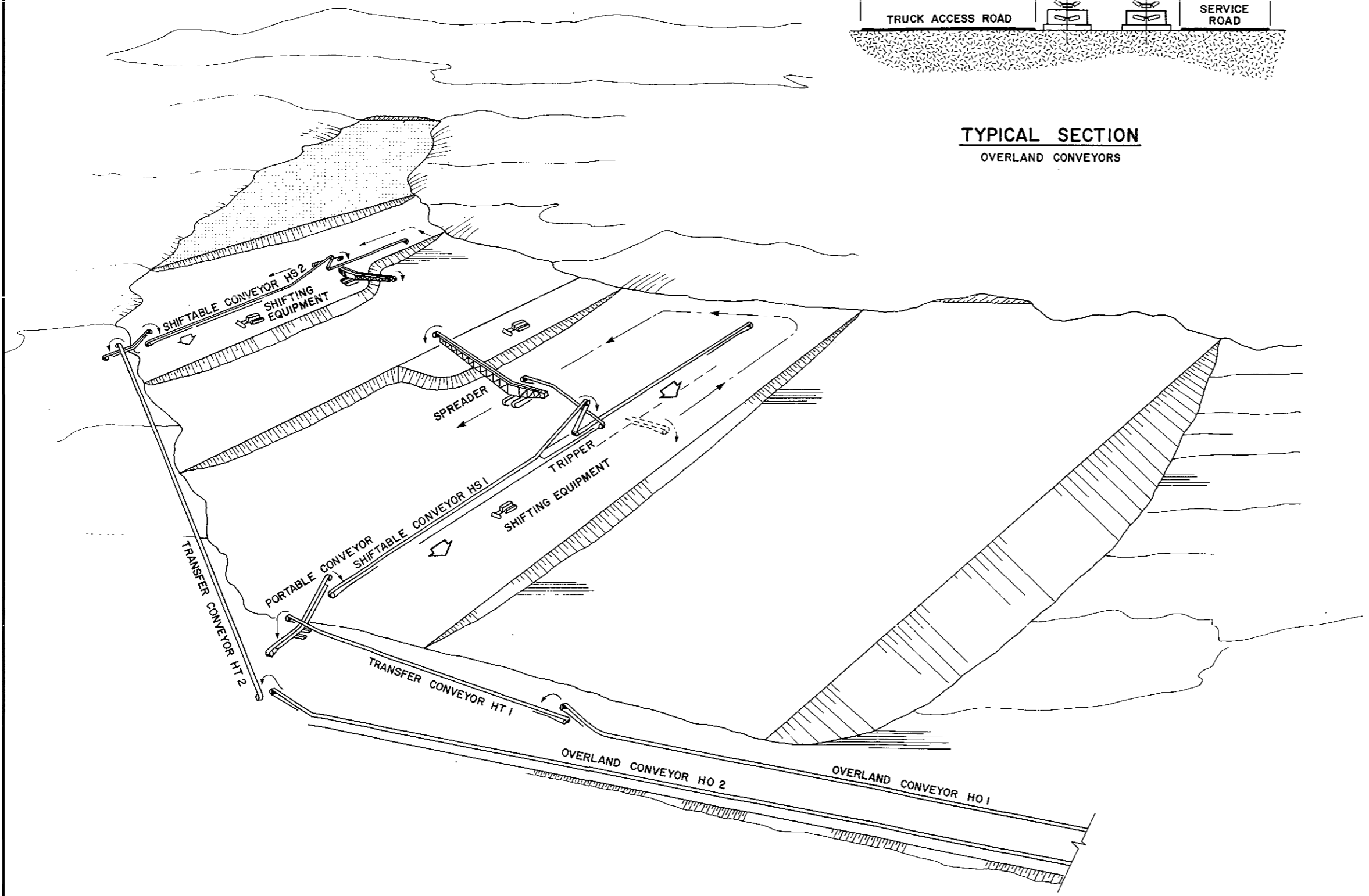

HAT CREEK PROJECT  
**FIGURE 8-7**  
**Pictorial View**  
**Waste Dump Development**

SOURCE: British Columbia Hydro and Power Authority

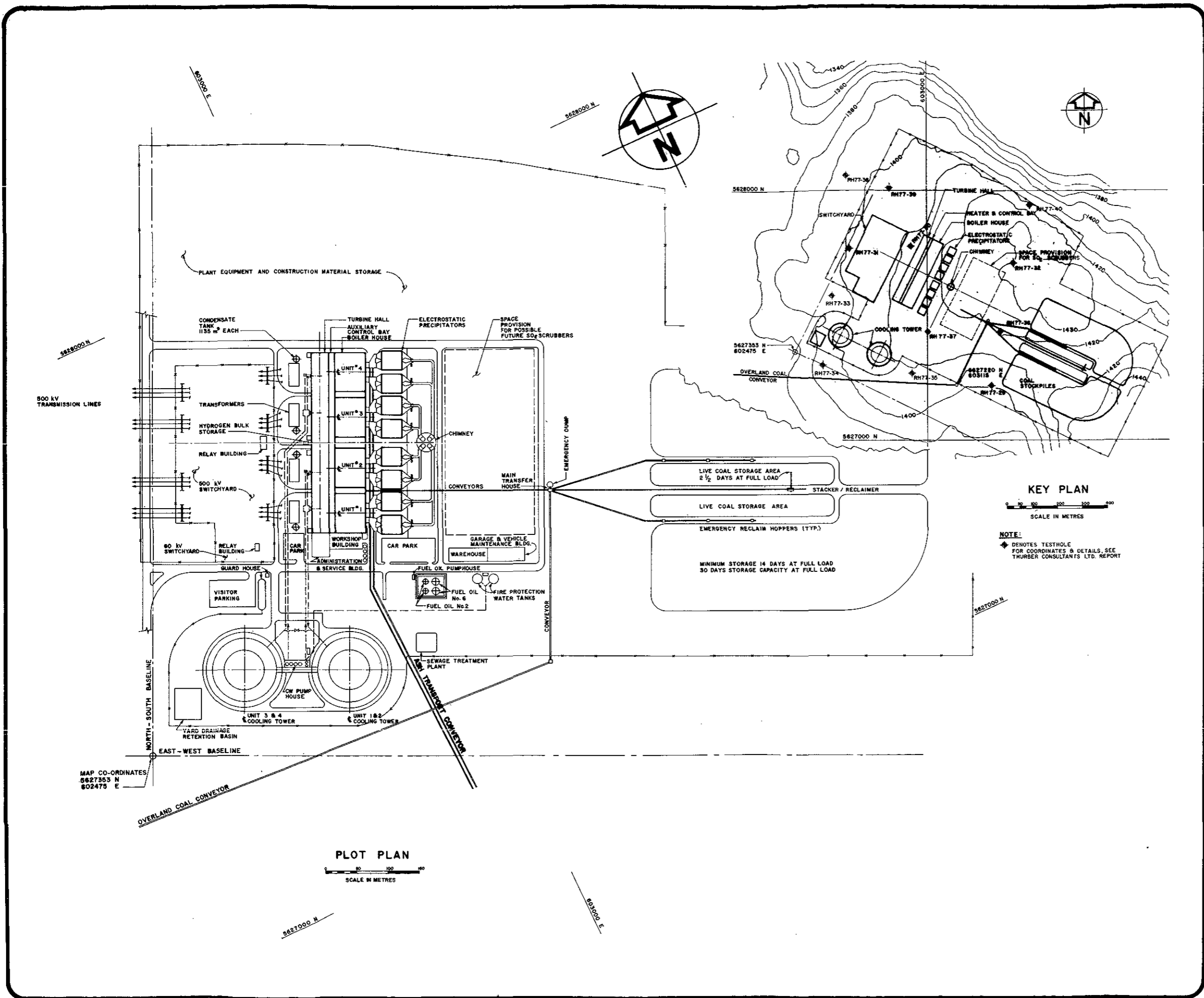

HAT CREEK PROJECT  
**FIGURE 8-8**  
**Powerplant — Plot Plan**

SOURCE: Integ-Ebasco

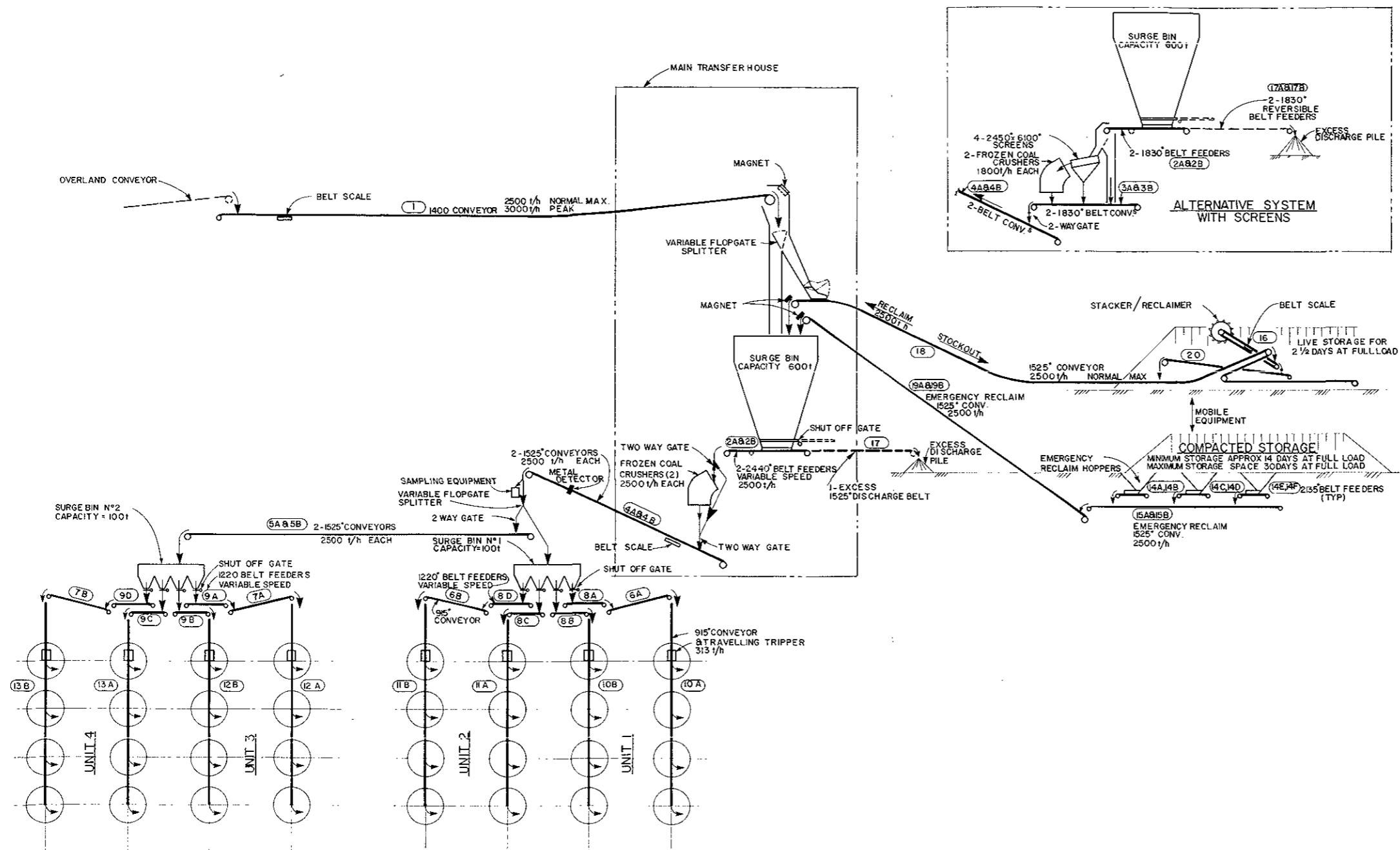

NOTE:  
 - ALL MEASUREMENT FIGURES ARE GIVEN IN MILLIMETRES.

HAT CREEK PROJECT  
**FIGURE 8-9**  
**Powerplant**  
**Flow Diagram of Coal System**

SOURCE: Integ-Ebasco

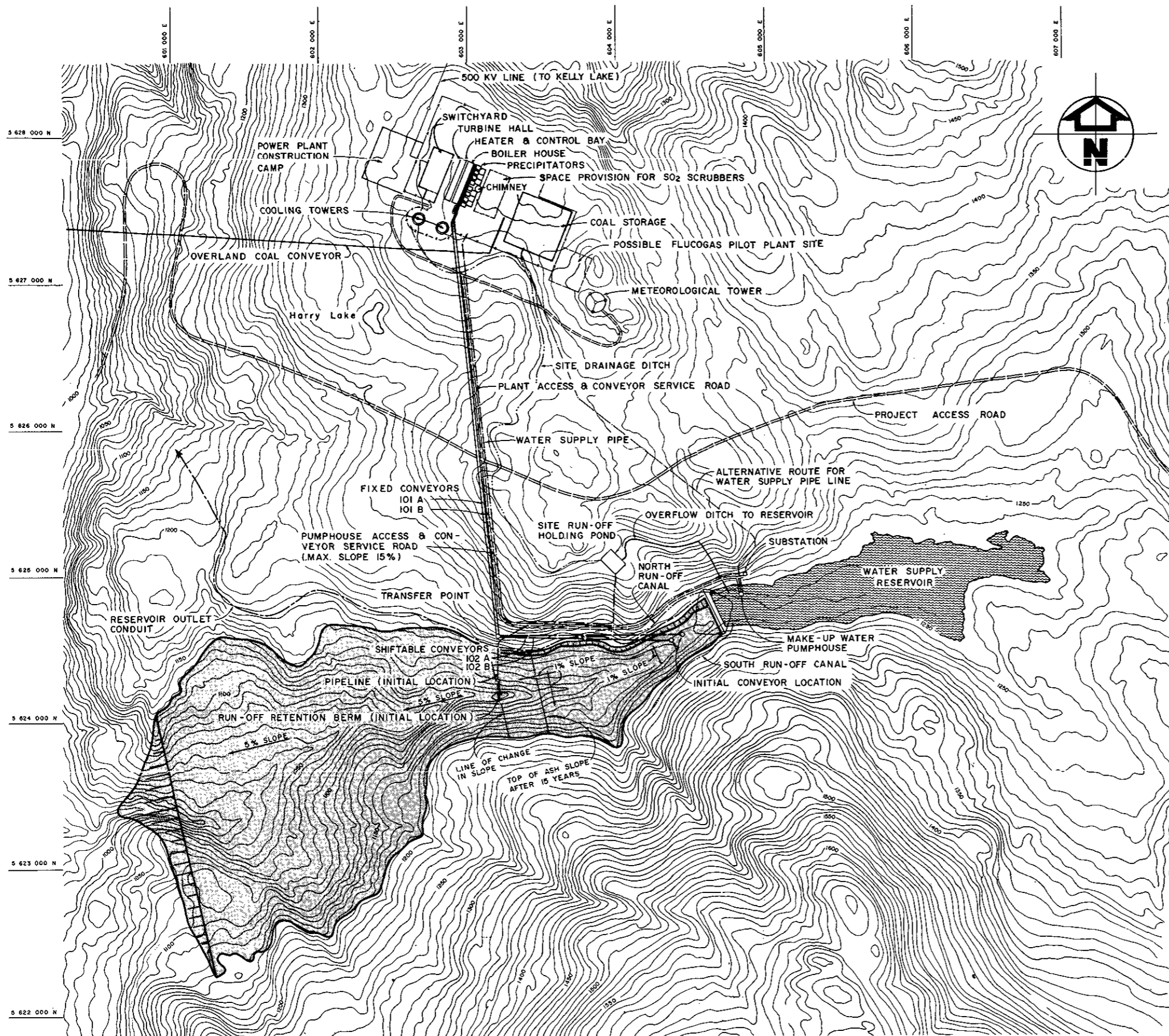

HAT CREEK PROJECT  
**FIGURE 8-10**  
**Powerplant**  
**Ash-Handling Scheme**

SOURCE: Integ-Ebasco

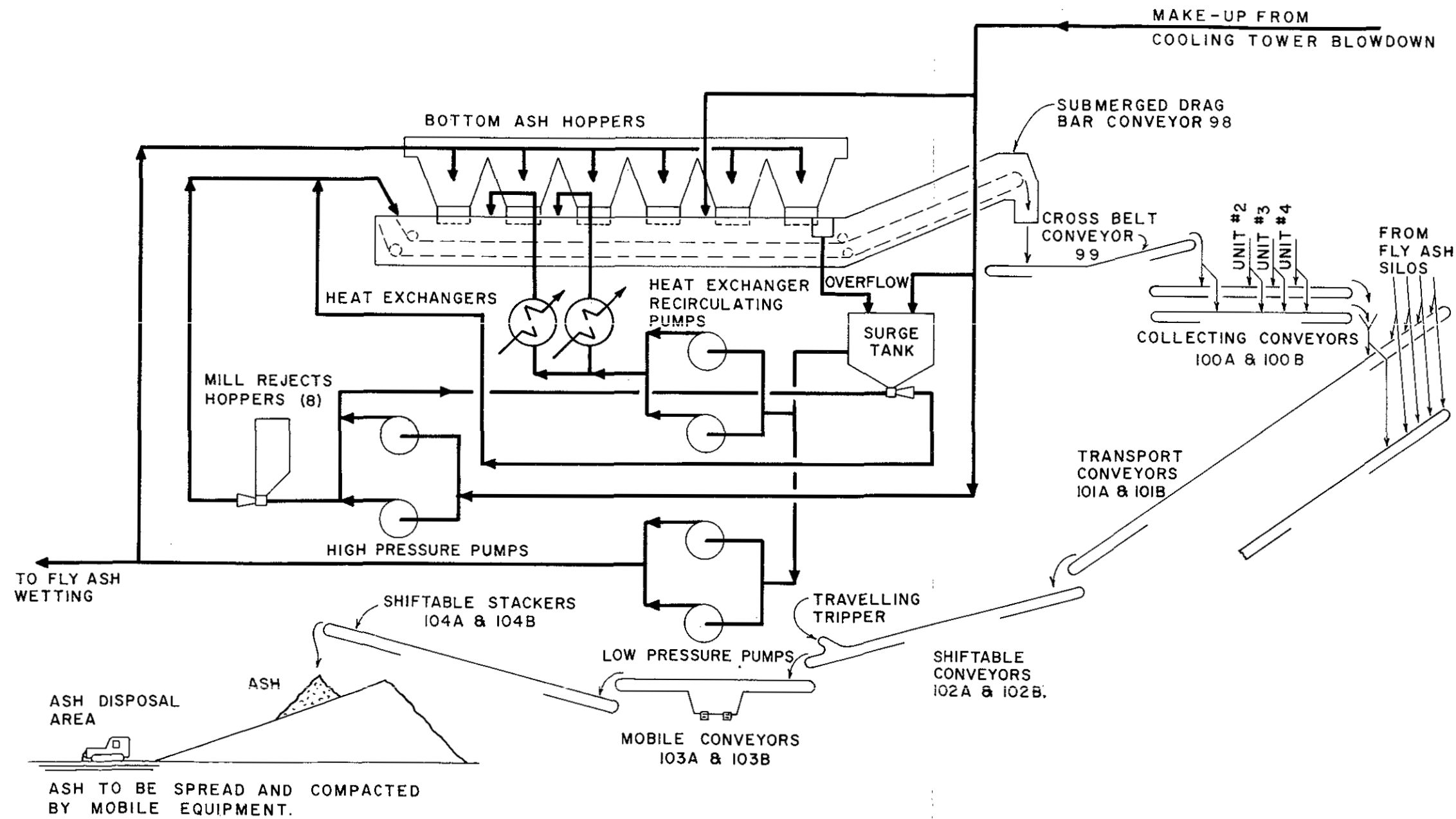

HAT CREEK PROJECT  
 FIGURE 8-11  
 POWERPLANT – FLOW DIAGRAM  
 BOTTOM-ASH REMOVAL

SOURCE: Integ-Ebasco

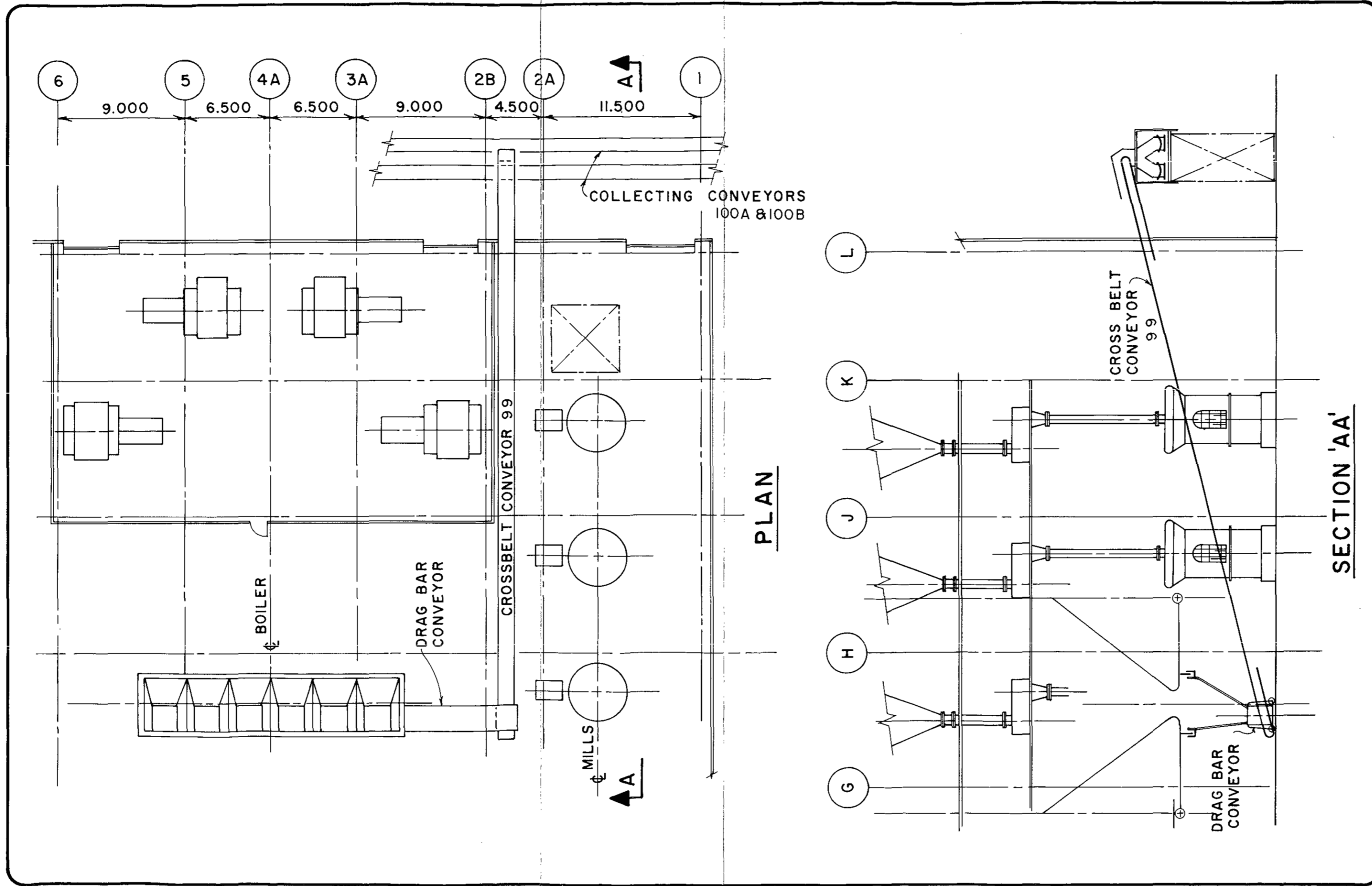

HAT CREEK PROJECT  
 FIGURE 8-12  
 Powerplant-General Arrangement  
 Drag-bar Conveyor for Bottom-Ash

SOURCE: Integ-Ebasco



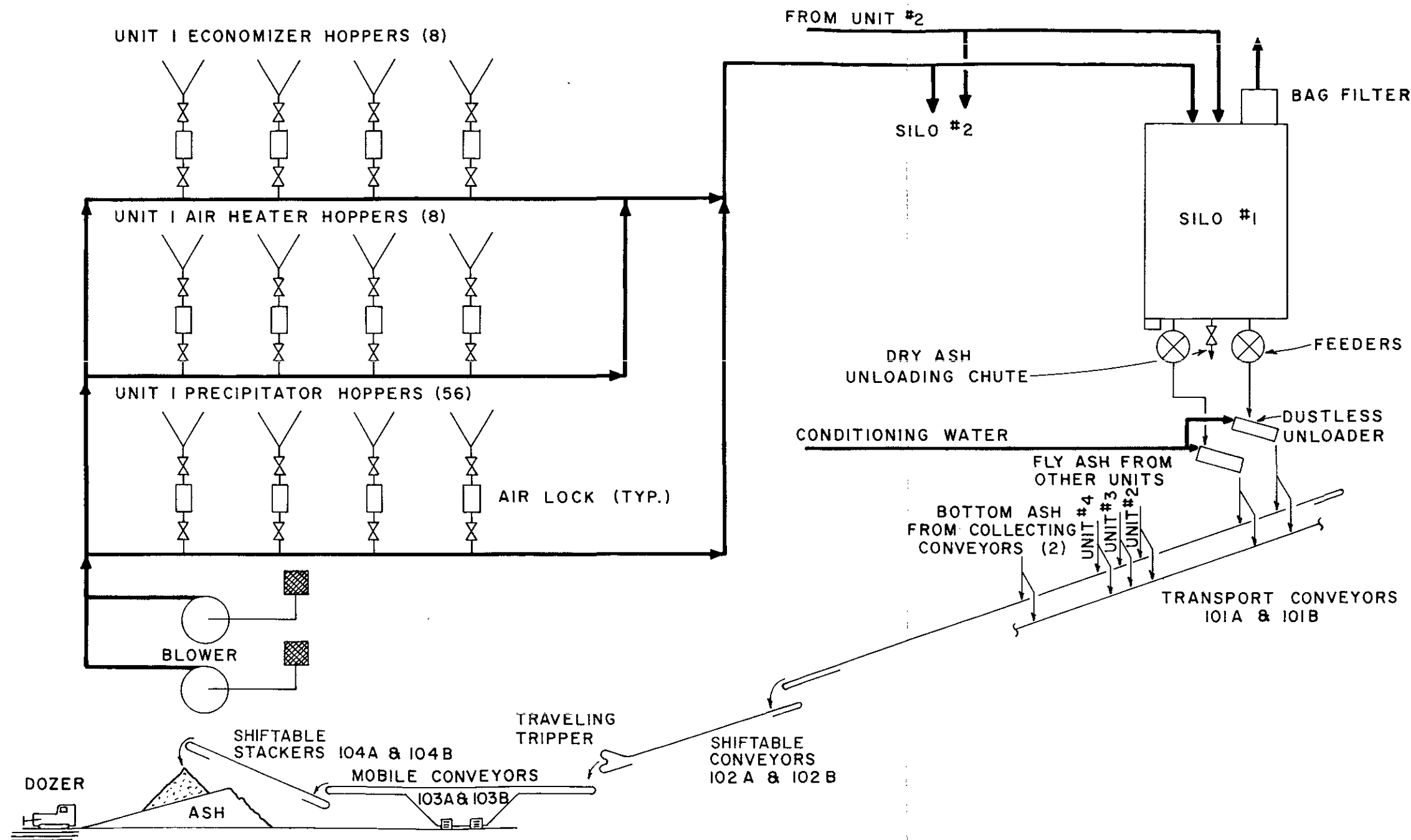

HAT CREEK PROJECT  
**FIGURE 8-13**  
**Powerplant — Flow Diagram**  
**Fly-Ash Pressure System**

SOURCE: Integ-Ebasco

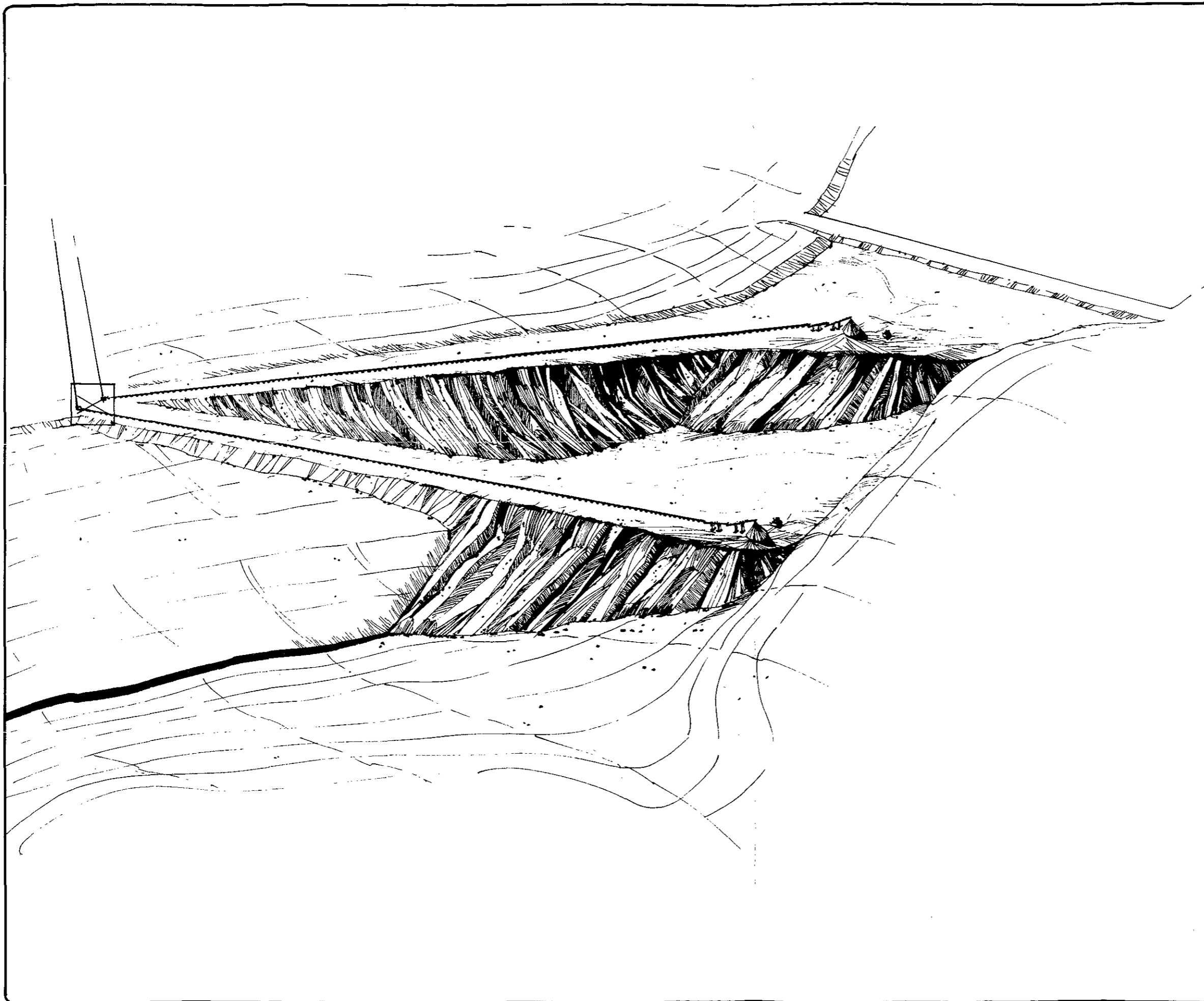

HAT CREEK PROJECT  
FIGURE 8-14  
**Isometric View  
Powerplant - Ash Disposal System**

SOURCE: Integ-Ebasco

9 EQUIPMENT

Page

9.1	Production Equipment	1
9.1.1	Coal Mining	2
9.1.2	Waste Removal	3
9.1.3	Operation at Maximum Capacity Rating	5
9.2	Support Equipment	7
9.2.1	Road Construction and Maintenance	7
9.2.2	Mine Support	8
9.2.3	Material-handling Support	10
9.2.4	Service Equipment	11

<u>No.</u>	<u>LIST OF TABLES</u>	<u>Page</u>
9-1	Mine Equipment List	13
9-2	Roads Scheduled for Construction	18

## SECTION 9

### EQUIPMENT SELECTION

This section discusses the selection of the equipment that will be used in the development and operation of the mine. The initial equipment is scheduled to become operational in Year -2 to commence pre-production development.

For the purposes of this study it has been assumed that any earth-moving required outside the limits of the pit for site preparation and construction purposes would be performed by contractors' equipment. The costs of this work have been provided in the construction capital cost estimates. This work could be reassigned to the mine crew and equipment with a minor revision of the schedule.

The mining equipment is divided into two groups: production equipment for loading and hauling coal and waste; and support equipment to execute the numerous other tasks required for the continuous, efficient operation of the mine.

#### 9.1 PRODUCTION EQUIPMENT

A preliminary evaluation of possible mining equipment was conducted to determine its suitability for the proposed methods of operation. The equipment that passed this initial screening was subjected to a detailed cost and productivity analysis in the context of the mine plan and schedule.

The cost and productivity analysis was performed considering the shovels and trucks as a system for three critical mining periods:

- (1) Year 6 - utilization of first dump pocket only; first high production period;
- (2) Year 9 - utilization of first and second dump pockets; multiple mining areas;

- (3) Year 21 - utilization of first, second, and third dump pockets; high coal production from lower benches.

These time periods include both long and short distances with uphill, downhill, and level hauls. For each year, haul road profiles were developed and truck travel times calculated. Fixed cycle times were developed for each shovel-truck combination. On level hauls, trucks were limited to a maximum speed of 40 km/h. On downhill hauls the speed limits were established to provide maximum braking capability.

### 9.1.1 Coal Mining

#### 1. Shovels

The selection of the coal shovel is dictated by the decision to adopt selective mining methods. The most effective shovel for this purpose is the hydraulic excavator. Because of the variability of the deposit, the more shovels available for operation, the easier it is to maintain a consistent quality of output. The need to provide flexibility for quality control and to permit effective partings removal at 2 m was balanced against the economics of using larger equipment. The machine selected for loading coal is a hydraulic shovel with a 10.7 m<sup>3</sup> bottom-dump bucket equivalent to the Poclain 1000.

In addition to the scheduled coal production, these shovels have been assigned a quantity of waste partings and low-grade coal to be removed each year equivalent to 20% of the coal tonnage.

Over the project life, between two and three shovels are capable of loading the assigned quantities of coal and parting materials. To provide the necessary flexibility for producing a uniform quality of coal, and to accommodate extended periods of powerplant operation at maximum capacity, four electrically-powered hydraulic shovels will be operational, except during the initial buildup to full production and a tailing-off period in the latter years of the project.

In the peak production years, coal will be mined from as many as 15 benches. During this period, a fifth shovel has been provided for to reduce the impact of numerous shovel moves. This additional shovel would be a diesel-powered unit and would be supplied with a backhoe attachment as well as the standard shovel front. This unit provides mobility and flexibility to the operation. The backhoe

attachment will also be useful in excavating sinking cuts and assisting in selective mining.

## 2. Trucks

Three sizes of diesel-electric haulage trucks were evaluated operating in conjunction with the 10.7 m<sup>3</sup> hydraulic shovel. These trucks were rated at 77 t, 91 t, and 109 t.

The economic analysis performed for the three selected critical periods showed a marginal cost advantage for the 77-t truck over the 91-t truck, with the 109-t truck ranked third. In reviewing the fleet size developed in the analysis, a better balance of trucks to shovels was obtained with the 77-t trucks, which were confirmed as the most suitable coal truck.

During the peak production years the number of 77-t trucks required ranges from nine to 11. The principal specifications of the truck are: 77 m<sup>3</sup> coal box; 1,000 hp engine; 24.00 x 49 tires, and a 23:1 gear ratio.

### 9.1.2 Waste Removal

There are two principal types of waste materials to be moved: consolidated and unconsolidated. The consolidated materials are typified by the claystones and siltstones of the Medicine Creek and Coldwater formations. Glacial till, and the sands and gravels on the East side of the pit are classified as unconsolidated materials, along with large quantities of bentonitic slide material on the West side.

#### 1. Shovels

The two different categories of waste material to be mined present very different problems. The consolidated waste is a saturated, soft, cohesive material, which, when frozen, will form a rock-like crust a metre or more deep during an extended cold weather period. When blasted, frozen clay breaks into chunky pieces that are not compatible with conveyor transportation. An alternative approach to blasting the claystones and siltstones would be to blast the material prior to freezing, using crater blasting techniques, a method that has proven effective in tar sands. However, because of the high moisture content of the clays, the effectiveness of this approach is questionable until operational testing can be done.

Because of the nature of the claystones, it was concluded that the most effective method of excavating this material would be to use hydraulic shovels. A Demag 241 with a 14.5 m<sup>3</sup> bucket is the only production unit in this size range currently available.

The application of this unit would require the assistance of a D-9 ripper to handle the frozen toe. Special attention will also be required in operational planning to maintain continuous operation during the Winter months to prevent the face freezing. It will also be necessary to prevent traffic travelling on top of material to be mined during the Winter, because of the greater depth of the frozen layer that this causes.

The unconsolidated materials present less serious excavating problems. This material can be excavated with either a standard mining cable shovel or a hydraulic shovel. A cost and productivity analysis was conducted to compare a 16.8 m<sup>3</sup> cable shovel with the 14.5 m<sup>3</sup> hydraulic shovel. The results showed marginal cost savings using the 16.8 m<sup>3</sup> shovel for loading unconsolidated waste. The study also demonstrated that additional equipment scheduling problems would be introduced with a mixed shovel fleet, causing an increase in the number and length of shovel moves. The hydraulic shovels have the additional advantages of being lighter in weight, exerting less ground-bearing pressure, and capable of travelling approximately twice as fast as the cable shovels.

These factors outweigh the insignificant cost savings of the cable shovel and resulted in the 14.5 m<sup>3</sup> hydraulic shovel being selected for loading both the consolidated and unconsolidated waste materials.

## 2. Trucks

Three sizes of diesel-electric haulage trucks being loaded by 14.5 m<sup>3</sup> hydraulic shovels were evaluated for waste haulage. These trucks were 109 t, 136 t, and 154 t. Other truck sizes were eliminated in a preliminary evaluation.

The economic analysis was performed using the same three critical periods identified above. The 154-t truck showed the lowest unit production costs and was selected for waste haulage. The principal specifications for the truck are: 90 m<sup>3</sup> rock box; 1,600 hp engine; 36.00 x 51 tires, and a 28.85:1 gear ratio.

Consideration was given to standardizing trucks for coal and waste, but the requirements for selective mining of coal dictate a smaller unit than is economically justified for moving larger quantities of waste over significantly different haul road profiles.



Under exceptional conditions the powerplant could be required, and be able, to operate at its full rated capacity for an extended period of up to six months. The plan presented in this report ensures that sufficient equipment is provided to meet the normal operational requirements established by the forecast operating regime. The purchase of additional equipment to cope with an event that is unlikely to occur is not justified where contingency plans can be implemented. The mining operation, as planned, has considerable flexibility to meet a number of widely varying conditions that can be used to meet emergency requirements for additional coal production.

It is assumed that any extended period of powerplant operation at maximum capacity rating will span the Winter months. This assumption is supported by the fact that maximum power demands occur in this period, transmission lines from more distant hydro-electric projects are exposed to greater hazards in the Winter, and the thermal powerplant at Hat Creek has extended maintenance scheduled for each unit during the Summer. It is also assumed that extended operation will not be required in successive years. Should the latter assumption prove wrong, additional equipment could be purchased. The additional equipment, primarily trucks, can usually be obtained with a three to six-month lead time.

The mining contingency plan only provides for mining additional coal during the emergency period. Existing plans provide for at least six months' coal to be uncovered at all times. In many time periods waste removal is even further advanced to facilitate a level production schedule. Thus it is not considered necessary to increase waste removal to cope with the emergency.

To meet the additional coal production requirement, adequate shovel-loading capability has already been provided to allow flexibility for coal production scheduling. The conveying systems are designed to handle peak hourly requirements. On an annual basis this means that the coal conveyor has a capacity 40% above the peak annual tonnage required. This does not include the use of the low-grade coal conveyor as a back-up facility. It is concluded that adequate conveying capacity exists.

The principal area for contingency planning is in the assignment of trucks. The re-assignment of one or two trucks from waste removal to coal production should be sufficient to provide the additional tonnage required. The larger 154-t waste trucks can be loaded by the 10.7 m<sup>3</sup> coal shovels. Although this would not use the trucks at maximum efficiency, the performance would be acceptable under emergency conditions.

Higher productivity is expected from trucks during the Winter months than during the remainder of the year. Experience in other operations indicates substantial productivity improvement in the Winter, primarily due to improved haul road conditions. This improvement is expected to be even more pronounced with the soft, weak materials at Hat Creek and will minimize the loss of waste production.

A further back-up system for coal production is the use of the smaller 32-t trucks loaded either by 10.7 m<sup>3</sup> shovel or by front-end loader. These trucks are available for use during the Winter months because of the limited road construction activity at this time. As a final back-up, additional shovels and trucks can be redirected from waste removal to coal production, and any shortfall in waste can be made up through the use of contractors.

The support equipment required for the mine can be broken down into four principal categories: road construction and maintenance; mine support; material-handling support; and general service equipment. There is a considerable overlap in the application of specific types of equipment to the different categories. Table 9-1 summarizes the total requirements of the major equipment types and their applications.

## 9.2.1

Road Construction and Maintenance

Because of the weakness of the materials at Hat Creek, considerable road construction will be required on virtually every bench to ensure that the production trucks and service equipment can operate efficiently. Truck haul roads will generally be constructed 25 m wide, with a one metre base topped with 20 cm of crushed gravel. It is estimated that half the roads to be constructed in a given year will require major construction. The remaining roads will be constructed on more stable gravel, till, and coal requiring only top dressing.

A major road building program will commence in the pre-production development period and continue throughout the life of the mine. Roads on the waste dump will be built intermittently; most of this work will be required immediately prior to the relocation of conveyor belts. The road construction requirements, shown in Table 9-2, decrease as permanent haulage roads are developed. The permanent roads above the present valley bottom will be operational in about Year 15, and below the valley bottom in Year 20.

Major haul road construction is restricted to the months of the year when the ground is not frozen, to avoid the problems that Winter-built roads have due to trapped excess moisture and poor compaction. It is planned to take advantage of the frozen conditions to gain access to the more unstable areas, using roads with only a minimum of surface topping.

The construction method for roads uses dozers to cut and fill where required and rough-level the foundation. Scrapers, aided by push dozers, would subsequently pick up run-of-mine gravels - mainly from the East side of the valley - in order to build up the lower portion

of the sub-base. The upper portion of the sub-base, including the running surface, would be crushed gravel or, when available, baked zone materials. The gravel crusher would be located on a gravel bench and fed by front-end loaders. It would convey crushed material to a pile for pick-up by scrapers or by front-end loaders for truck transport. Graders and vibrating compactors would complete the final surface. Provision has been made for water trucks for both the construction phase described above and for subsequent road maintenance practice.

From pre-production to Year 5, the bulk of road construction activity will be handled by 705 hp tandem-powered 16 m<sup>3</sup> struck capacity scrapers assisted by D-9 push-cat. During pre-production, the scrapers will remove an estimated 2.2 million m<sup>3</sup> of waste materials, the majority of which will be used to construct roads. From Year 6 onwards, the haul distances required for road construction lengthen beyond the economic limits for scraper use, and the 32-t trucks loaded by front-end loaders, assisted by D-9 dozers, become the primary equipment for this function. From Year 12 on, the number of working benches decreases and with it the amount of road construction in each year.

The bench pioneering operation is intermittent and involves cut and fill work at designated bench elevations. This work will provide a sufficient number of ramps and level operating space for subsequent shovel/truck operations. The principal equipment used for bench pioneering will be scrapers and D-9 dozers.

Caterpillar 16-G graders or equivalent will be used in the construction and maintenance of the haul roads. Grader requirements were established based on each grader maintaining 3 km of road per shift. A smaller, 14-G grader has been provided for in the estimates to maintain the narrower service roads around the property.

Provision has been made in the estimates for the purchase and operation of the major road construction equipment and for all aspects of road maintenance, including snow removal, dust and ice control, gravel crushing, and ditch maintenance.

## 9.2.2 Mine Support

### 1. Drilling

It is anticipated that the majority of the coal and waste materials can be excavated using hydraulic shovels without blasting.

However, exploration drilling has identified bands of cemented conglomerate that may require fragmentation to permit efficient loading operations. In addition, during the bulk sample program, an isolated plug of fused material was uncovered in the burn zone material that had to be blasted. No further plugs of this type have been identified in the drill holes, but it is reasonable to expect that more, similar plugs exist. An allowance has been made to drill and lightly blast 10% of the waste materials to cover these events.

Two drills have been included in the equipment list for the drilling of blast holes: a truck-mounted auger drill and a tracked percussion drill, complete with a 17 m<sup>3</sup>/s air compressor.

The principal production drilling would be performed by the auger drill, which would require only one shift a day, five days a week, to perform this task. The auger drill would also be used for close-spaced drilling for coal quality control. The percussion drill would be used in irregular terrain and in drilling material too hard for the auger.

Because of the expected low volume of drilling and blasting, the purchase of an AN-FO mix truck is not justified. Pre-packaged explosives transported by a 5-t stake-body truck would be used.

## 2. Shovel Support

Rubber-tired dozers will be supplied for clean-up operations around the shovels and for pit floor maintenance. Each Cat 824B rubber-tired dozer will service up to three operating shovels. During peak production years, three of these machines will be required.

Assistance in selective mining and excavating frozen waste materials will be provided by D-9 rippers. To assist selective mining of coal, the dozers will remove bands of coal or waste that the shovel has difficulty in digging cleanly. The support to the waste shovels will be: to rip frozen material on the crest of the bench to prevent unsafe overhangs developing; and also to rip frozen toe material to ensure the excavation of flat benches.

## 3. Pit Clean-up

Pit clean-up will be provided using front-end loaders and 32-t trucks. The clean-up function includes removal of boulders and petrified wood rejected by the shovels and removal of accumulations of saturated clay from bench toes or bladed-off haul roads.

Material-handling Support1. Waste Dumps

Each waste stacker system will be provided with two D-8's for maintaining a uniformly sloping dump surface, general dump maintenance, and shifting the waste conveyors. For the conveyor-shifting operation, additional dozers will be required either from the other stacker or the mine. The dozers assigned to the waste dumps will normally remain there because of the travel distance to other parts of the mine. Other duties for the dozers include any necessary land clearing and snow removal.

Periodically, conveyor pads must be constructed prior to relocation of a conveyor and areas of the dump that are inaccessible to the stackers must be filled. After Year 16, the filling of these areas is required on a continuous basis. This work will be performed using front-end loaders to load 32-t trucks with waste deposited by the stacker in a location as close as possible to where it is required.

2. Secondary Crushing and Blending Area

A 5.4 m<sup>3</sup> front-end loader will be assigned to the secondary crushing and blending area for clean-up and stockpile maintenance. Stockpile maintenance includes any movement of coal required to permit the efficient operation of the stacker and reclaimer and also to dig out any areas where spontaneous combustion develops.

Emergency reclaim capability, when the reclaimer is unable to operate, will be provided through a portable skid-mounted conveyor fed by front-end loaders. The loader assigned to the area would be augmented by equipment from the mine.

3. Conveyor Line Clean-up

Spillage under the conveyors will be removed using a tracked dozer loader equipped with a rake attachment. Two of these machines will be required to cover the full length of the installed conveyors.

Routine clean-up around the truck dump stations will be handled by the rubber-tired dozers assigned to shovel support. Removal of oversize material from the crushers will be handled periodically by front-end loaders and 32-t trucks.

## 9.2.4

Service Equipment

A fleet of emergency vehicles and service equipment will be required to maintain the mobile equipment fleet and the conveyor belt systems:

	<u>Number Required</u>
(1) Emergency vehicles:	
1. Fire trucks	2
2. Ambulances	2
(2) Cranes:	
1. 70 t	1
2. 50 t	1
3. 15 t	3
(3) Recovery vehicles:	
1. Low-boy tractor trailer	1
2. Hi-boy trailer	1
(4) Mechanical maintenance vehicles:	
1. 5-t mechanic's truck	4
2. Tire truck	1
3. 22,730-L fuel truck	2
4. Lube truck	2
5. 3-t Hiab truck	2
6. 17-m <sup>3</sup> compressor	1
7. Steam cleaner	3
8. 50-kW portable generator	1
(5) Fuelling station	1
(6) Electrical maintenance:	
1. Line truck	1
2. 1-t electrician's van	2
3. Light plants	6

		<u>Number Required</u>
(7)	Warehousing equipment:	
	1. 2,700-kg forklift	2
	2. 4,500-kg forklift	1
(8)	Personnel transportation:	
	1. 1-t four-wheel drive trucks	8
	2. 1-t pick-ups	26
	3. 3/4-t pick-ups	26
	4. Management cars	7
(9)	Pit buses:	
	1. 24-passenger	5
	2. 10-passenger	2

Miscellaneous other equipment required includes: conveyor belt vulcanizers, belt reeler, and cable reeler.



MINE EQUIPMENT LIST  
Equipment Type and Job Application

Item	Description	Fleet Size
Production Equipment:		
<u>10.7 m<sup>3</sup> Shovel</u>		
Years:	- pre-production	1
	- 3	3
	- 5 to 23	5
	- 24 to 35	4
Job application:	- Loading coal and low-grade coal	
	- Loading waste partings	
<u>14.5 m<sup>3</sup> Shovel</u>		
Years:	- pre-production	1
	- 3	3
	- 5 to 18	4
	- 23 to 35	2
Job application:	- Loading consolidated waste	
	- Loading unconsolidated waste	
<u>77-t Truck</u>		
Years:	- pre-production	3
	- 1	6
	- 5 to 7	10
	- 13 to 18	11
	- 25 to 35	8
Job application:	- Hauling coal and low-grade coal	
	- Hauling waste partings	

<u>Item</u>	<u>Description</u>	<u>Fleet Size</u>
<u>154-t Truck</u>		
Years:	- pre-production	3
	- 1	6
	- 5	12
	- 10 to 14	14
	- 25 to 35	8
Job application:	- Hauling consolidated waste	
	- Hauling unconsolidated waste	
Support Equipment:		
<u>D-9 Dozers</u>		
Years:	- pre-production to 3	4
	- 5 to 22	5
	- 23 to 35	3
Job application:	- Road construction and maintenance	
	- Bench pioneering	
	- Scraper assistance	
	- Front-end loader assistance	
	- Shovel assistance:	
	- partings removal	
	- ripping hard and frozen materials	
	- pit clean-up	
<u>D-8 Dozers</u>		
Years:	- pre-production to 5	7
	- 6 to 10	8
	- 10 to 35	7
Job application:	- Road construction and maintenance	
	- Front-end loader assistance	
	- Bench pioneering and land clearing	
	- Snow control	
	- Dump activities:	
	- spreader assistance	
	- levelling of spoil	
	- dump maintenance	
	- conveyor shifting	

<u>Item</u>	<u>Description</u>	<u>Fleet Size</u>
<u>D-7 Dozers</u>		
Years:	- pre-production to 5	1
	- 5 to 26	2
	- 27 to 35	1
Job application:	- Road construction and maintenance	
	- Pit clean-up	
<u>32-t Truck</u>		
Years:	- pre-production	3
	- 4 to 35	6
Job application:	- Road construction and maintenance	
	- Conveyor pad and causeway construction	
	- Pit clean-up	
<u>Wheel Dozer</u>		
Years:	- pre-production	1
	- 1 to 4	2
	- 5 to 20	3
Job application:	- Shovel and bench clean-up	
	- Road maintenance	
<u>Scraper - 16 m<sup>3</sup></u>		
Years:	- pre-production to 7	6
	- 8 to 10	4
	- 11 to 35	2
Job application:	- Road construction and maintenance	
	- Topsoil removal and replacement	
	- Bench pioneering	
<u>9.6 m<sup>3</sup> Front-end Loader</u>		
Years:	- Mine life	2
Job application:	- Road construction and maintenance	
	- Shovel back-up	
	- Pit clean-up	
	- Emergency reclaim of coal stockpiles	

<u>Item</u>	<u>Description</u>	<u>Fleet Size</u>
<u>5.4 m<sup>3</sup> Front-end Loader</u>		
Years:	- pre-production to 3	2
	- 4 to 22	3
Job application:	- Road construction and maintenance	
	- Pit clean-up	
	- Oversize reject handling	
	- Dump activities	
	- Bench pioneering	
<u>16G Grader</u>		
Years:	- pre-production	3
	- 3	5
	- 4 to 12	6
	- 13 to 22	5
	- 23 to 35	3
Job application:	- Road construction and maintenance	
	- Grading on dumps	
<u>14G Grader</u>		
Years:	- Mine life	1
Job application:	- Road construction and maintenance	
	- Snow control	
<u>Backhoe</u>		
Years:	- Mine life	1
Job application:	- Construction and maintenance of ditches	
	- Construction and maintenance of dewatering sumps	
<u>Gradall</u>		
Years:	- Mine life	1
Job application:	- Road maintenance	
	- Ditch and culvert maintenance	

Item	Description	Fleet Size
------	-------------	------------

Drills

Type:	Auger	- Mine life	1
	Percussion	- Mine life	1

Job application:

- Exploration drilling
- Close-spaced drilling
- Burn zone materials drilling
- Drilling of oversized boulders

Additional Equipment:

Water truck	3
Mobile crusher	1
Wheeled compactor	1
Towed compactor	1
Diesel pumps	10
CaCl spreader	4
Low-boy tractor/trailer	1
Hi-boy tractor/trailer	1

TABLE 9-2

ROADS SCHEDULED FOR CONSTRUCTION  
(kilometres)

Year	In-pit Roads	Dump Conveyor Pads	Total
-2	4		4
-1	8	3	11
1	9	4	13
2	14		14
3	21		21
4	29		29
5	32		32
6	32		32
7	31	4	35
8	32	5	37
9	32		32
10	34		34
11	34		34
12	32		32
13	32	2	34
14	30		30
15	29		29
16	27		27
17	26	2	28
18	25		25
19	23		23
20	23	5	28
21	22		22
22	22		22
23	22		22
24	22		22
25	22	2	24
26	20		20
27	20		20
28	20		20
29	21		21
30	21		21
31	21		21
32	21		21
33	21		21
34	11		11
35	10		10
			<u>882</u>

10	<u>MINE SUPPORT FACILITIES</u>	<u>Page</u>
10.1	Introduction	1
10.2	Mine Services Area	2
10.2.1	Location	2
10.2.2	Facilities Required	2
10.2.2.1	Administration Building	2
10.2.2.2	Maintenance Complex	3
10.2.2.3	Mine Services Building	6
10.2.2.4	Field Maintenance Centre	7
10.2.2.5	Rubber Repair Shop	7
10.2.2.6	Laboratories	8
10.2.2.7	Lubricant Storage Building	9
10.2.2.8	Fuel Storage and Dispensing Area	10
10.2.2.9	Mine Dry	11
10.2.2.10	Storage Areas	11
10.2.3	Structural Description of Buildings	12
10.2.4	Services to Buildings	13
10.2.4.1	Water Supply	13
10.2.4.2	Electrical Distribution	13
10.2.4.3	Heating, Ventilating, and Air Conditioning	14
10.2.4.4	Lighting	14
10.2.4.5	Sewage Disposal	15
10.2.4.6	Fire Protection	15
10.2.4.6.1	Mine Services Area	15
10.2.4.6.2	Coal Handling Systems	16
10.2.4.6.3	Open Pit	17
10.2.4.6.4	Waste Conveyors	17
10.2.4.6.5	Mine Equipment and Vehicles	17
10.2.4.7	Surface Drainage	17
10.2.4.8	Security	18
10.2.5	Construction Period Requirements	19
10.2.5.1	Construction Schedule	20
10.2.5.2	Construction Period Facilities	20
10.2.5.3	Mine Equipment Erection Area	20
10.3	Utilities	21
10.3.1	Water Supply	21
10.3.1.1	Introduction	21
10.3.1.2	Water Requirements	21
10.3.1.3	Water Sources	22

	<u>Page</u>
10.3.1.4 Proposed System	23
10.3.1.4.1 Source of Supply	23
10.3.1.4.2 Mine Services Area	23
10.3.1.4.3 Coal Blending Area	24
10.3.1.4.4 Overland Coal Conveyor	24
10.3.1.4.5 In-Pit Water Supply	24
10.3.1.4.6 Revegetation Nursery	25
10.3.2 Mine Power Supply	25
10.3.2.1 Introduction	25
10.3.2.2 Electrical Loads	25
10.3.2.2.1 Power Shovels	25
10.3.2.2.2 Voltage Regulations	26
10.3.2.2.3 Estimated Annual Power Demands and Energy Consumption	26
10.3.2.3 Network Design Criteria	27
10.3.2.4 System Description	28
10.3.2.4.1 General	28
10.3.2.4.2 Pit Area	29
10.3.2.4.3 Houth Meadows Waste Dump	29
10.3.2.4.4 Medicine Creek Waste Dump	30
10.3.2.4.5 Mine Service Facilities	31
10.3.2.4.6 Crushing/Blending Plant	31
10.3.2.4.7 Reliability	31
10.3.2.4.8 Construction Power	32



<u>No.</u>	<u>LIST OF TABLES</u>	<u>Page</u>
10-1	Preliminary Estimates of Consumptive Water Requirements	33
10-2	Water Quality Data	34
10-3	Total Estimated Mine Load During Peak Years	35
10-4	Estimated Annual Load and Energy Demands	36

LIST OF FIGURES

10-1	Mine Services Area - General Arrangement	37
10-2	Administration Building	38
10-3	Maintenance Complex	39
10-4	Mine Services Building and Rubber Repair Shop	40
10-5	Mine Dry	41
10-6	Mine Power Distribution Network	42
10-7	Typical Portable Sub-station Layout	43
10-8	Typical Permanent Sub-station Layout	44

## SECTION 10

### MINE SUPPORT FACILITIES

#### 10.1 INTRODUCTION

This section describes the facilities required to support mining operations at Hat Creek. These support facilities include an administrative centre; maintenance, service, and emergency facilities; and utilities supply and distribution. In all cases, consideration has been given to functionality, safety, fire protection, and provision for expansion.

The Mine Services Area would be just North-East of the pit, covering an area of approximately 40 ha. Included within the services area are buildings for administrative and personnel requirements, equipment repair shops, storage, laboratories, and open areas for parking, additional storage, and equipment erection. Initial development of the services area would commence in the middle of Year 4, concurrently with erection of some major mining equipment, and nine months prior to "breaking ground" in the actual pit.

The two utility services costed in this study, water and power supply, are discussed in Sections 10.3.1 and 10.3.2.

The overall recommended mining operation does not require large quantities of water; at full mine development, the maximum average daily requirement would be 2,855 m<sup>3</sup>, which would be sufficient for drinking water, fire protection, irrigation, and dust control. Water would be supplied from the powerplant supply line from the Thompson River, the pit rim reservoir on Hat Creek, and drainage from the mine area.

The electrical power supply and distribution system at the mine is designed to accept power from the 60 kV busbar at the proposed Hat Creek Generating Station, and to distribute it wherever required at voltages varying from 60 kV to 120 v. Construction power requirements would be met from an existing 60 kV line adjacent to Highway 12, North of the mine development. A maximum of eight portable sub-stations would be strategically located in the mine area. Operation of equipment is the largest power requirement of the project, the major equipment functions comprising mining in the pit, coal conveying, crushing and blending, and spreading operations at the waste dumps. Additional power demands include pit dewatering, mine area lighting, and complete electrical servicing of the buildings and facilities in the Mine Services Area.

## 10.2 MINE SERVICES AREA

### 10.2.1 Location

The proposed location of the Mine Services Area, to the North of the pit, was chosen for its proximity to the pit access road, out-of-pit conveying system, and Coal Blending Area. An additional consideration in choosing this location is that it does not affect the mining of future coal reserves in the Upper Hat Creek Valley. Geological investigations to date have indicated that no coal reserves are present beneath the proposed Mine Services Area. Furthermore, the proposed area for development is well drained, sufficiently level to preclude any major problems in site preparation, and large enough (40 ha) to accommodate the proposed service area, with ample room for expansion, during the anticipated 35-year life of the mine.

### 10.2.2 Facilities Required

The following structures and facilities comprise the Mine Services Area for the Hat Creek Mine:

- Administration Building;
- Maintenance Complex;
- Mine Services Building;
- Field Maintenance Centre;
- Rubber Repair Shop;
- Laboratories;
- Lubrication Storage Building;
- Fuel Storage and Dispensing Area;
- Mine Dry;
- Storage Areas.

The general layout of these facilities is shown on Figure 10-1.

#### 10.2.2.1 The Administration Building

The proposed Administration Building, located in landscaped surroundings on the Western edge of the Mine Services Area, is close to

the entrance to the proposed project access road and is also easily accessible from all other facilities in the area (see Figure 10-1). The proposed building is a two-storey structure with a total floor area of 1,770 m<sup>2</sup>, containing 50 office spaces as well as adequate storage area, service facilities, and a conference room (see Figure 10-2).

The ground floor has been arranged to provide offices for senior staff members and service and administrative departments such as accounting, data processing, payroll, personnel, and purchasing. Engineering departments such as mine planning and geology would be located on the upper floor with adequate office space and drafting area.

#### 10.2.2.2 The Maintenance Complex

This structure, of dimensions 189.0 m x 50.0 m and 0.945 ha area, is centrally located in the Mine Services Area, providing easy access to the repair and service shops for the in-pit vehicles, as well as to the other support facilities such as the Rubber Repair Shop, Administration Building, and the Mine Dry (see Figure 10-1). The building layout is shown on Figure 10-3 and consists of the following work and storage areas.

8 Haul truck repair bays	10.5 x 18.5 m
4 Tractor repair bays	10.5 x 18.5 m
8 Auto repair bays	5.25 x 9.25 m
2 Steam-clean bay/wash down bays	10.5 x 15.0 m
Welding and fabricating shop	1,350 m <sup>2</sup>
Machine shop	850 m <sup>2</sup>
Electrical repair shop	280 m <sup>2</sup>
Radio and instrument repair shop	60 m <sup>2</sup>
Hydraulic repair shop	200 m <sup>2</sup>
Warehouse areas	
- palletized	2,000 m <sup>2</sup>
- small piece (shelved)	385 m <sup>2</sup>
- flammable goods store	100 m <sup>2</sup>
- tool crib	70 m <sup>2</sup>

Planning area	300 m <sup>2</sup>
Fire Truck Storage Bay	6.5 x 12.0 m
Ambulance Storage Bay	6.5 x 12.0 m
First Aid Centre	78 m <sup>2</sup>
Training Centre	150 m <sup>2</sup>
Mechanical service rooms	110 m <sup>2</sup>
Battery Room	25 m <sup>2</sup>

The internal layout of the maintenance complex was designed to the following assumed criteria:

- (1) maintenance, planning, and supervisory office areas should be central and have easy access to all parts of the complex;
- (2) the vehicle repair bays should be within easy reach of warehouse storage of spare parts and materials; and
- (3) the vehicle repair bays should have easy access to ancillary repair and service areas such as the machine shop, welding and fabricating shop, etc.

The number of repair bays was determined by using anticipated mechanical availabilities for the various types of equipment.

All work areas in the complex will be supplied with compressed air, water, power, and oxyacetylene from bulk storage facilities. General service equipment such as welding machines, powered hand tools, welding screens, bench and floor-mounted grinders, and drill presses will also be supplied as required. In areas where fumes and dust will be a problem, such as the welding shop and steam bay, fume hoods and/or extractor fans should be provided.

Each shop area will include a foreman's office in addition to specialized equipment.

#### The Truck Repair Shop

This will be equipped with a 30 t overhead electric travelling crane fitted with a 5 t auxiliary crane, controlled from floor level, to accommodate work on the 77 t and 154 t mine trucks. Other equipment will include 100 t hydraulic jacks, a lubrication rack complete with hose reels to dispense all necessary fluids and greases in the service bays, and waste-oil disposal tanks from which the waste oil is pumped to a holding tank in the fuel storage and dispensing area (see Figure 10-1). A 10 m-wide concrete apron will be provided adjacent to the entrances to this and the following two shops.

#### The Tractor Repair Shop

This will be equipped with a 15 t overhead electric travelling crane with floor-level controls. A lubrication rack and a waste-oil disposal system, as described earlier, will be supplied in the service bays.

#### The Auto Repair Shop

This will be equipped with a 10 t overhead electric crane, plus floor-mounted hydraulic vehicle lifts of 500 kg capacity.

#### The Welding/Fabricating Shop

This will be equipped with a 25 t crane, as earlier described, as well as 2 t jib-type cranes. The specialized equipment in this shop should include a universal iron worker, plate rolls, profile cutter, air-arcing equipment, blacksmith furnace, and welding booths.

#### The Machine Shop

This will be equipped with a 12 t overhead electric crane, plus 2 t jib cranes to service various machine tools such as 750, 430, and 275 mm lathes, 150 mm horizontal boring mill, 1,400 mm x 280 mm milling machine, 2,000 mm radial arm drill, 550 mm stroke shaping machine, key-seater, surface plate, 75 t and 300 t hydraulic presses, cleaning tanks, and precision gauges. A strip-down and assembly area will be designated.

#### The Electrical Repair Shop

This will be equipped with a 12 t overhead crane and other related equipment such as testing equipment, cleaning tanks, and drying oven.

#### The Warehouse

This will be equipped with 2,250 kg and 4,500 kg capacity forklift trucks in the covered warehouse area to handle the loading, unloading and storing of palletized parts. Handling of larger and heavier components will be by mobile yard cranes as required, either in outside yards or coal storage buildings. Small parts will be stored in bins.

Necessary office space for warehouse personnel and inventory records is included.

10.2.2.3 The Mine Services Building

This building, with its ancillary storage yard, is located in the Eastern section of the Mine Services Area (see Figure 10-4) and covers an area of approximately 1.8 ha. It is easily accessible for "in-pit" and maintenance building requirements, as well as delivery of raw materials and spare parts via the mine access road.

The following services are included in this facility:

Sheet Metal and Pipefitters' Shop	215 m <sup>2</sup>
Carpenters' Shop	245 m <sup>2</sup>
Painters' Shop	95 m <sup>2</sup>
Supervisory office space	85 m <sup>2</sup>
Winter and/or night storage for vehicles (will also serve as extra workspace for carpenters and pipefitters when required)	400 m <sup>2</sup>
Material Storage Area and tool crib	50 m <sup>2</sup>
Personnel areas - punch in/out area, washrooms, locker space, lunchroom, and janitorial room	200 m <sup>2</sup>
Open storage yard	1.6 ha
Covered plywood and timber storage	100 m <sup>2</sup>

The various shop areas in the building will be equipped with necessary tools and equipment as follows:

The Sheet Metal and Pipefitters' Shop

This will be equipped with a sheet metal shear and former, spot welder, bench grinder, drill press, pipe threader, bandsaw, overhead monorail and hoist, and miscellaneous handtools.

The Carpenters' Shop

This will be equipped with a bench saw, radial arm saw, drill, planer, and necessary handtools.

### The Painters' Shop

This will be equipped with portable spray painting equipment.

An outside parking area, equipped with electrical plug-in receptacles, will be provided to accommodate overnight parking of miscellaneous service vehicles.

#### 10.2.2.4 The Field Maintenance Centre

Most of the work carried out by the crews operating from this building will be in the field, and therefore no major equipment need be supplied in the building. Bench-mounted grinders and a pedestal drill press will be installed, along with a welding machine and oxyacetylene equipment.

Service trucks equipped with welding machines, oxyacetylene equipment, compressors, lifting equipment, and handtools will provide the services required for the field work. Line trucks will be available for maintenance of the mine electrical power system.

Any other equipment required for major overhauls or major repairs will be supplied from the maintenance complex or Mine Services Centre.

#### 10.2.2.5 The Rubber Repair Shop

This building houses three separate service and repair shops for tires (225 m<sup>2</sup>), conveyor belting (300 m<sup>2</sup>), and trailing cables (225 m<sup>2</sup>), and is located in the Southern section of the maintenance and service area within easy access of the pit and main conveyor routes (see Figure 10-4).

### The Tire Shop

Mine production vehicles requiring tire service will have easy access to a heated concrete apron in front of the tire repair building, where tires will be mounted using portable hydraulic jacks and a 13,500 kg capacity forklift, complete with tire manipulator attachment. Minor repairs only should be done in-shop while major repairs should be carried out off-site by a suitable contractor.



### The Conveyor Belting Shop

The Conveyor Belt Repair Shop will be equipped to handle belt splicing and belt repairs, both in the shop and in the field, using portable vulcanizing equipment suitable for use with steel cord or fabric ply belting. The reels of belt will be handled by a mobile crane in the storage area and by an overhead monorail at the powered belt reelers in the shop area. The shop will be equipped with all necessary handtools such as knives and belt cutters. Power supply to this building at 600 v would be used directly for the vulcanizing equipment, while a step-down to 120 v would be necessary for lighting, heating, ventilation, power tools, etc. A cold-storage building will be provided for proper storage of conveyor belt splicing and repair materials.

### The Cable Shop

This area will be provided for repairing and testing mine cables. Typical equipment in the shop includes powered reels, repair benches, test panels, overhead cranes, and necessary handtools.

#### 10.2.2.6 Laboratories

The following laboratory facilities will be provided:

- an assay/environmental analytical laboratory in the Mine Services Area (see Figure 10-1);
- an environmental services complex situated on a parcel of presently cultivated land to the South-East of the pit near the confluence of Hat Creek and Medicine Creek (see Figure 10-2).

#### The Assay/Environmental Analytical Laboratory

Located adjacent to the Administration Building, this facility consists of:

- a general office area, conference room and reception area (300 m<sup>2</sup>);
- a "wet" laboratory area to be used by both environmental and assay staff for sample analysis;
- a dry-coal laboratory, used solely for coal sample analysis (150 m<sup>2</sup>);
- a core-sample handling area (150 m<sup>2</sup>);

- a sample storage area (75 m<sup>2</sup>);
- equipment storage (50 m<sup>2</sup>).

A central enclosed walkway will separate the wet laboratory and office area from the dirtier, coal-handling facilities; precautions will be taken to prevent dust emissions from the latter area.

Core storage sheds will be provided in the vicinity of the Coal Blending Area, with only sufficient core for analytical testing being transported to the laboratory. A shed will also be provided for logging and splitting cores.

Adjacent parking space will be provided for staff work vehicles and vehicles delivering samples.

#### The Environmental Services Complex

This group of structures will be built on presently developed agricultural land (proposed as potential nursery area) and consist of:

- a "Lord & Burnam"-type greenhouse (aluminum and glass construction), heated, ventilated, and equipped with necessary lighting (105 m<sup>2</sup>);
- a "Quonset"-type greenhouse (50 m<sup>2</sup>);
- a service building containing reception area, office and drafting areas, and sample preparation room (150 m<sup>2</sup>);
- a reclamation/agricultural machinery shed (300 m<sup>2</sup>);
- bulk fertilizer storage (8 m<sup>2</sup>).

#### 10.2.2.7 The Lubricant Storage Building

As shown in Figure 10-1, this building is located adjacent to the North-East corner of the maintenance complex to provide good access for both delivery vehicles and mine service vehicles. The building should be heated and insulated and house bulk storage tanks for the various lubricating oils and greases required for the mine mobile equipment. The types and quantities of stored materials are as follows:

Motor oil	30 kL
Hydraulic oil	30 kL
Transmission fluid	30 kL
Gear oil	30 kL
Chassis grease	9,000 kg
Track grease	9,000 kg

The various lubricants will be pumped on demand in heated underground piping to the maintenance complex and then to dispensing racks in service bays in the truck, tractor, and auto repair shops.

The storage tanks of mine lube trucks will be replenished at an external loading station forming part of the building. A portable lube island in the mine complements this facility and will be located conveniently close to the main haulage route for quick servicing of trucks whenever necessary. Less-mobile equipment such as tracked equipment will be serviced on location by the lube truck.

#### 10.2.2.8 The Fuel Storage and Dispensing Area

A fuel tank farm with diesel fuel and gasoline dispensing pumps will be located in the Eastern edge of the Mine Services Area, close to the main mine haulage access road and approximately 100 m from the maintenance complex. Access will be provided around the tank farm for the mine fuel trucks, other service vehicles, pick-up trucks, and the fuel supplier's tank truck. A safety berm will be constructed around the farm area to contain any spillage of fuel.

The tank farm will contain diesel fuel, gasoline, mixed anti-freeze, and waste oil storage tanks of 364, 90, 55, and 45 kL, respectively, these amounts of fuel being equal to approximately one week's predicted consumption rates.

Metered bulk loading and unloading facilities for use by the mine fuel trucks and fuel supplier's trucks, as well as dispensing pumps for the general mine use, will be supplied in this area.

An in-pit fuel facility is also provided for the use of the haulage truck fleet and is located in the same area as the in-pit lube island. Other mobile equipment such as tracked vehicles will be fuelled by the mine fuel trucks. The fuel island, receiving its supplies from the supplier's tank truck as required, will have portable horizontally-mounted diesel fuel tanks of approximately 45 kL total capacity, provided with trays to contain accidental spillage, and will be complete with metered loading and unloading facilities.

#### 10.2.2.9 The Mine Dry

The Mine Dry will be divided into four basic areas: dirty lockers, clean lockers, washing area, and mine supervision and marshalling area. Provision will be made for installation of 700 "clean" lockers and 700 "dirty" lockers so as to allow a locker of each type for every person on the mine labour force (see Figure 10-5).

Janitorial space and mechanical equipment rooms will also be provided.

Separate dry areas will be provided for male staff members as well as female work crew members.

The heating and ventilating systems will be designed to accommodate the hot and humid conditions expected in a washroom area. The ventilation system will be designed so that the air is directed through the locker spaces to facilitate drying of clothes, and then into the building. The building will be constructed of non-combustible materials, and provision of a full complement of hydrants and fire extinguishers is recommended, rather than installation of a sprinkler system.

#### 10.2.2.10 Storage Areas

The location and size of various storage facilities in the mine service area have been based on consideration of their expected use, access from the work areas in which the stored materials are to be used, the ease of moving materials within the storage area, the need to monitor incoming and outgoing materials, and the possible need for future expansion.

The main storage areas are shown on Figure 10-1 and are described below.

##### Yard storage

An area of approximately 3.6 ha will be fenced and manned for materials control. Large parts requiring covered storage will be housed in an unheated building constructed of light metal. The area will be arranged to allow easy access for service vehicles and yard cranes.

### Shop area storage

Individual storage areas are recommended for the parts and materials used in the various shop areas. The area recommended (approximately 2.7 ha) is centred mainly around the Mine Services Building and Rubber Repair Shop, where a large area is required for storage of tires, rolls of belting, cable reels, and lumber.

A separate fenced area adjacent to the Tire Repair Shop will be provided to permit the secure storage of small vehicle tires. Various rubber repair materials may be stored in a refrigerated building within this fenced area.

### Construction storage area

The construction storage, or "laydown", area will be used initially for the storage of materials and equipment during the construction period, and thereafter for the storage of supplies for the pit and mine service area.

## 10.2.3 Structural Description of Buildings

Buildings will be constructed of light structural steel frame over reinforced concrete floors and footings. Where necessary, structures will be designed for extra loading imposed by travelling cranes, overhead office space, heating and ventilating units.

External walls will generally be built of insulated metal cladding, as specified and detailed by Toby, Russell, Buckwell and Partners, architectural consultants to B.C. Hydro. Sections of the wall adjacent to vehicle access roads or doors into the building will be constructed of reinforced concrete to doorhead height, so as to minimize damage in case vehicles collide.

Internal dividing walls will be built of concrete blockwork or moveable prefabricated panels.

Roofs will be constructed of insulated metal cladding and will be sufficiently sloped to facilitate proper drainage. The exterior cladding is insulated to conserve heat in Winter and keep the shops cool in Summer. The thickness of insulation is designed to accommodate the large variations in temperature expected in the Hat Creek Valley. As with the wall cladding, the roofing is specified and detailed by the architectural consultant.

Because of their very rough usage in heavy-duty repair shops, shop floors will generally be constructed of reinforced concrete, using only a hard abrasion-resistant aggregate. In particularly hard-worked areas, a chemically-hardened wearing surface will be applied to minimize surface break-up and "dusting". To permit a good workable floor, special consideration will be given to producing a well-compacted, capable, load-bearing sub-grade. As drainage of shop areas is of prime importance, care should be taken in pre-designing all floor openings and trenches for services such as water, electrical cables, and exhaust piping, so as to prevent future disruption of drainage systems.

#### 10.2.4            Services to Buildings

##### 10.2.4.1        Water Supply

Water will be provided to all buildings in the Mine Services Area by a buried pipe reticulation system.

##### 10.2.4.2        Electrical Distribution

Each of the maintenance, office, and service buildings will receive incoming power supply at 6.9 kv transmitted via underground cable. A MVA 6.9 kv to 600/347 v sub-station will be located adjacent to each building. The large-size and high Winter heating load of the maintenance complex will necessitate three 1 MVA sub-stations, one to be located centrally and one at each end of the building. Power from these sub-stations will be distributed within the buildings at 600/347 v with 600 v receptacles provided throughout. Transformers of 600/120 v and panel boards complete with single-phase 120 v circuitry and receptacles will be provided where necessary. The type and number of power outlets will be designated according to the layout and designed use of each building, and an adequate number of spare panel board circuits will be made available to allow for future growth of building power load.

In workshop areas such as the machine shop and welding/fabricating shop, a plug-in three-phase 600/347 v bus duct will be used. This bus duct will be suspended from the ceiling structure of the building and provides a high degree of flexibility in future equipment locations.

#### 10.2.4.3 Heating, Ventilating, and Air Conditioning

Electrical heating units are planned throughout, and air conditioning systems will be provided for the Administration Building, as well as the office areas in the mine dry and maintenance complex. Ventilating systems will be provided throughout all buildings, with special attention given to hazardous areas such as the Paint Shop, Woodworking Shop, and Rubber Repair Shop.

#### 10.2.4.4 Lighting

Lighting in maintenance and service facilities is designed to standards recommended by the Illuminating Engineering Society. Specific recommendations for lighting fixtures and intensity are as follows:

- (1) In any inside work area of high-ceiling bays with a ceiling height greater than 4.0 m, 1,000 w high-intensity discharge lamps should be spaced so as to provide even light intensity;
- (2) Office areas should be lit with 4-tube, 1.2 m fluorescent luminaires;
- (3) Where required, outdoor lighting should be provided by 1,000 w high-intensity discharge lamps. The fixtures should be suspended from buildings themselves, where possible, or mounted on poles or towers;
- (4) Emergency lighting fixtures should be provided in stairways and passageways of all buildings. Self-contained twin lamp battery packs will be used;
- (5) Lighting in hazardous areas such as the Rubber Repair Shop, Paint Shop, and lubricant storage area should be provided, using suitably enclosed and sealed 3-tube, 1.2 m fluorescent units.

#### 10.2.4.5 Sewage Disposal

Sanitary effluent from the mine service complex will be pre-treated and discharged to a holding pond, and will be seasonally used for dust control in the mine. Allowance has been made for a package wastewater treatment plant capable of handling 140 m<sup>3</sup>/d of effluent at 400 ppm BOD<sub>5</sub>.

If necessary, the treated effluent could be disinfected prior to being sprayed on roads in the mine area; however, no provision has been made for this at present.

Water from equipment washdown facilities will be discharged to stormwater drains via a grease and grit trap, from where it will flow to sedimentation lagoons for primary treatment prior to discharge. The integration of these facilities into the overall mine drainage and water supply systems is discussed further in Section 6.

#### 10.2.4.6 Fire Protection Systems

A fire protection system will be provided to protect capital investment in buildings and equipment and to minimize the danger of fire causing a major shutdown of coal supply to the generating station.

Permanent automatic systems will be installed in high-risk areas. Where there is "medium" risk, a permanent water supply will be provided for hoses or fire trucks. There will be no permanent installations in low-risk areas; spot fires will be extinguished by fire trucks supplied by water tankers.

##### 10.2.4.6.1 The Mine Services Area

This is a relatively high-risk area within the mine development, and insurance underwriters' standards have been used to define fire protection requirements. Automatic fire detection systems will be installed in all buildings, with a central alarm panel in the proposed fire truck bay.



Automatic sprinkler systems are proposed for all maintenance workshops and service buildings other than the Administration Building and Mine Dry Building, which would be relatively low-risk areas, constructed of non-combustible materials.

All buildings will have a standard complement of fire extinguishers, as well as 40 mm standpipes complete with run-out hoses situated to provide coverage of the building floor plan.

Fire hydrants will be located within the service area, so as to further protect buildings and the open yard storage areas around the perimeter.

The water supply system to the service area will maintain a reserve of 1,000 m<sup>3</sup> of water for firefighting, and will be capable of supplying 95 L/s at 415 kPa at connections to buildings.

Two four-wheel drive fire trucks will be based at the Mine Services Area which will be used as required throughout the entire mine development area. These trucks will carry about 2,000 L of water, fire pumps, hose reels, and ladders.

#### 10.2.4.6.2 Coal Handling Systems

The Coal Conveyor from the pit to the Coal Blending Area and the Overland Conveyor to the generating station will be under the surveillance of an automatic fire detector system which will identify the location of a fire and prevent its spread by stopping the conveyor.

Conveyor transfer stations and enclosed sections of the Overland Conveyor will be protected by automatic sprinkler systems fed from a buried water main adjacent to the conveyorway. Exposed sections of conveyor will be protected by fire trucks which will gain access by a proposed service road, and will draw water from fire hydrants adjacent to the conveyor. In the Coal Blending Area buried water mains between the stockpiles will supply water to fire hydrants. Service roads will be provided between stockpiles to allow access for fire trucks and crews.

#### 10.2.4.6.3 The Open Pit

Within the open pit, water tankers and fire trucks will be used to extinguish spot fires. A permanent water supply will be available from the water main at the North conveyor incline; a hydrant will be provided at each bench. A further allowance has been made for 10,000 m of 75 mm aluminum pipe should an in-pit water supply main be required during mining operations.

#### 10.2.4.6.4 Waste Conveyors

These systems will be surveyed by an automatic fire detection system similar to that for the coal conveyors. Permanent fire protection systems will not be installed on the conveyorways to the waste dumps and water tankers; fire trucks will be used instead.

#### 10.2.4.6.5 Mine Equipment and Vehicles

All mine vehicles will be equipped with portable extinguishers for vehicle safety. Supervisors' and safety officers' vehicles will carry larger units for emergency use on mine equipment.

#### 10.2.4.7 Surface Drainage

Because of the need for ample drainage in the Mine Services Area, a comprehensive system of ditches and culverts is recommended to cope with the estimated 10-year flood. This will be the stormwater collection system.

A 750 mm corrugated steel pipe installed with catch basins will be routed through the centre of the maintenance and service area to receive runoff from the central yard area, as well as the roof drainage from the Administration Building, Laboratory, Mine Dry, and Maintenance Complex.

Storage areas, parking areas, general landscaped areas, and service shops should be drained by means of a network of ditches channelling the runoff to the water treatment area. To facilitate this drainage, general areas should be sloped at 0.5% to perimeter ditches or catch basins, and buildings would be drained via 300 mm buried corrugated pipes to the perimeter ditches or central 750 mm pipe.

All of the runoff from this area is planned to be collected at the West end of the service area, from where it would be carried by culverts and ditches to the sedimentation lagoons. Sewage effluent and leachate from coal-handling plant areas will be collected in a separate drain system and fed to the leachate storage lagoon.

#### 10.2.4.8 Security

It is intended that a 2 m high maximum security barrier will enclose the Mine Services Area, the Coal Blending Area, and the construction storage area. This barrier will be a heavy duty mesh fence topped with a barbed-wire strung overhead section.

Controlled access to this area will be provided at the following four points around its perimeter:

- (1) A main entrance from the public access road will lead into the Mine Services Area and the entrance to the pit and blending areas. A guardhouse will be provided at this entrance to maintain a 24-hour full security check of incoming and outgoing traffic. The entrance will be large enough for two opposite flows of traffic, with the guardhouse located centrally between the traffic lanes;
- (2) A second entrance from the main access road to the coal-blending yard is planned, but a permanent guardhouse will not be provided. It is intended that this gate be locked and opened as required by selected mine personnel;
- (3) A gate will be provided in the vicinity of the main conveyor transfer point and adjacent to the Houth Meadows Waste Conveyor for the use of the conveyor service crews with their vehicles.
- (4) A similar gate will be provided adjacent to the Medicine Creek Waste Conveyor.

North of the project area, security fencing will be strung across Hat Creek Valley adjacent to Highway 12 to discourage public entry to the congested area in the valley bottom between the blending area and the Houth Meadows Retaining Embankment. A lockable gate will be provided across the existing Hat Creek road.

Security fencing will also be provided around the larger, fixed electrical sub-stations. Security and safety barriers for other electrical components, moveable or fixed, within the mine area are included in the design and construction of those components. A further run of security fencing would surround the explosives magazine. In total, approximately 7.5 km of security fencing is to be installed.

As the mine will operate on a 24-hour basis, general lighting for the security fence need not be provided, but future illumination of selected areas should be considered by the mine security personnel.

It is proposed to enclose the entire mine project area within a low-security barrier to keep out livestock, as well as to provide a visual deterrent to the public. This barrier would be a three-strand barbed-wire fence strung between 1.5 m high metal posts at 4 m intervals. At the commencement of mining operations, 24 km of this type of fencing should be erected around the 35-year limits of the pit and the Houth Meadows Waste Dump, and up both sides of the main coal conveyor. In about Year 16, a further 14.5 km of ranch fencing should be erected around the 35-year Medicine Creek Waste Dump and Waste Conveyor. A fenced corridor should be provided through the project area for the diverted access road to the Upper Hat Creek area. Notices should be posted at suitable intervals around this fenceline, warning people against trespass for the sake of their own safety.

#### 10.2.5 Construction Period Requirements

Temporary facilities for personnel, materials, and equipment will be required during construction of the permanent mine support facilities. These temporary facilities are outlined below.

#### 10.2.5.1 Construction Schedule

According to this schedule (Section 12), all mine support facilities will be ready for use when required for the general mining operations. The schedule takes into account engineering and purchasing, anticipated delivery periods, and assembly of equipment and materials.

#### 10.2.5.2 Construction Period Facilities

Construction period facilities would include a temporary camp to house the construction work force; the camp does not form part of this study and is not discussed further. It is assumed that the supply of the necessary construction buildings, shops, etc., would be the responsibility of the respective contractors during construction of the various structures and erection of the initial mining and conveying equipment. It is assumed that temporary office and warehousing facilities would be erected to house the construction management team and B.C. Hydro's construction and management group during the construction period.

#### 10.2.5.3 Mine Equipment Erection Area

A mine equipment erection area of 12 ha is provided at the Northern end of the proposed mine perimeter, close to the conveyor ramp, the Mine Services Area, and serviced by access roads for the movement of materials and equipment. The area is large enough for the simultaneous erection of two mining shovels, and has sufficient storage space for miscellaneous components of other equipment awaiting erection, as well as for various small buildings, offices, and other facilities.

The area will be well drained and supplied with water and power.

10.3            UTILITIES

10.3.1        Water Supply

10.3.1.1     Introduction

This section of the report presents the estimated water supply requirements for the mine development and describes the layout of the proposed supply and distribution systems. Consideration was given to the integration of the mine supply with parallel systems proposed for the thermal generating station and the construction camps.

10.3.1.2     Water Requirements

The mine and adjacent service complex will require a permanent water supply during the years of operation of the mine. The mine water supply system must provide for the estimated demand from the following areas and services:

- |  |   |
|--|---|
| Potable Water for the Mine Services Area | - Administration Building                       |
|  | - Mine Dry                                      |
|  | - laboratories                                  |
|  | - maintenance buildings                         |
| Fire Protection Systems                  | - buildings                                     |
|  | - in-pit coal conveyor                          |
|  | - overland coal conveyor                        |
|  | - Coal Blending Area                            |
| Washdown Water                           | - vehicles and equipment                        |
| Irrigation Waters                        | - mine service area lawns and landscaping       |
|  | - revegetation nursery                          |
| Dust Control                             | - roads   |
|  | - Coal Blending Area                            |
|  | - low-grade coal stockpile                      |
| Temporary Construction Supply            | - during construction of the Mine Services Area |

A preliminary estimate of the water requirements of the mine at full development is shown on Table 10-1. Fire requirements are not shown as they do not form a day-by-day consumptive demand. Fire protection for buildings in the Mine Services Area would require the provision of 1,000 m<sup>3</sup> of reservoir capacity and a flow of 95 L/s at a residual pressure of 415 kPa at risers (M & M Consultants 1978). At the Coal Blending Area allowance has been made for a flow of 30 L/s at 415 kPa for fire control at the stockpiles.

Water quality standards for potable and irrigation water supply are presented by Beak (1978). These criteria were utilized in the selection of the source for these systems. The quality of dust control water is, however, not critical, and the supply requirements may be satisfied by recycling wastewater from the mine operation.

#### 10.3.1.3 Water Sources

Four alternative sources of supply were considered and are discussed in detail in the CMJV Feasibility Report Vol. IV.

- Water from the proposed generating station supply which will be taken from the Thompson River;
- Surface water from the proposed Hat Creek Diversion Canal located to the East of the mine;
- Groundwater from a well sunk to the North-East of the Mine Services Area;
- Recycled mine wastewater.

The major factors in the selection of a suitable source are water availability, cost of treatment, and supply. The locations of ancillary plant and mine facilities were considered as well, in order to provide an integrated system and to avoid duplication.

10.3.1.4 Proposed Water System

10.3.1.4.1 Source of Supply

Water for the mine development will be supplied from the following sources:

Potable Water and Fire Protection

Water for these uses will come initially from an integrated groundwater supply system with the project temporary construction supply. When the permanent generating station supply from the Thompson River comes on line, the construction supply pipeline from Hat Creek Valley to the powerplant will become the main supply line for potable water in the Mine Services Area. This water will require minimum treatment prior to use. Fire protection requirements will also be supplied by this line. A backup supply could also be provided by the use of treated surface water from Hat Creek.

Irrigation

Water for irrigation will be supplied from the Pit Rim Reservoir to the South of the open pit.

Dust Control

These requirements would be satisfied by recycling wastewater and pit dewatering flow.

The proposed water supply system is shown on the mine drainage and water supply flow chart, Figure 6-3 in Section 6.

10.3.1.4.2 Mine Services Area

The Mine Services Area would be fed from a reservoir located near the proposed construction camp. A booster pumphouse at the Eastern perimeter would increase line pressure to 700 kPa using two electric pumps of total capacity 100 L/s. A gasoline-driven fire pump of 100 L/s capacity would also be installed to provide water for fire control in the case of



power failure. A water main approximately 1,700 m x 200 mm would provide a water supply for the Mine Services Area, provide potable water to buildings, supply fixed sprinkler fire protection systems in buildings, and fire hydrants in open yard storage.

#### 10.3.1.4.3 Coal Blending Area

Provision has been made for a permanent dust control and fire protection system at the Coal Blending Area. Buried mains approximately 2,100 m in length beneath the stacker corridors would supply water to fire hydrants located at 100 m spacing between the coal piles. Dust control would be provided by oscillating water jets which could be mounted between the stacker rails and reclaimer units. During Summer the dust control system would be fed from the leachate holding pond as part of an evaporative disposal system for leachate. Make-up water to the system and fire reserve would be provided by the open pit fire protection supply.

#### 10.3.1.4.4 Overland Coal Conveyor

Water for fire protection of conveyor belts and transfer stations will be supplied from a buried main following the conveyor. A service road along the conveyor will allow access by fire truck to hydrants along the conveyor route. Frost protection may be required to prevent freeze-up of this pipeline during Winter. The relatively high head loss in the pipe (i.e., 450 m over its 4 km length) may require water hammer protection and pressure-reducing valves at lower points of supply.

#### 10.3.1.4.5 In-Pit Water Supply

Allowance has been made for the construction of a 150 mm water main on the main conveyor incline to provide a supply of water for fire protection of the conveyor and loading stations. Further provision has been made for 10,000 m of 75 mm aluminum in-pit distribution main which would be available for temporary use. The primary source of water for dust control on pit roads would stem from the reclaim water system, which recycles wastewater from the leachate holding pond. Make-up water for this system would come from pit dewatering flows or the permanent fire supply, as required.

#### 10.3.1.4.6 Revegetation Nursery

The proposed Revegetation Nursery to the South of the mine would be remote from the Mine Services Area and would therefore have a separate water supply.

Water would be taken from the pipeline which interconnects the Pit Rim Reservoir with the Hat Creek Diversion Canal and supplied to irrigation spray systems.

Potable water requirements at the adjacent reclamation laboratory would be provided by a small package water treatment unit.

#### 10.3.2 Mine Power Supply

##### 10.3.2.1 Introduction

This section of the report describes the electrical power distribution system used on the basis of estimating the cost of supplying power to the pit, waste dumps, and support facilities. The network developed includes all electrical equipment required to supply power from the 60 kV busbars of the proposed Hat Creek generating station to the open pit and dump areas, and to distribute the power within these areas to the shovels, conveyors, spreaders, and to the crushing and blending equipment. The developed network also includes supply for the various service buildings and provides the construction power required during the development phase of the mine.

##### 10.3.2.2 Electrical Loads

###### 10.3.2.2.1 Power Shovels

The load cycle for a large electrically-powered hydraulic shovel consists of a large surge of power required to hoist and swing the load to a small load during the dump portion of the cycle.

The acceptability of such a load, or the need to compensate for the power swings generated, can only be resolved through a comprehensive study of the utility network. However, the proximity of the proposed generating station to the Hat Creek Mine and the choice of shovels equipped with rectifier inverters should preclude the need for any additional compensating equipment.

The use of rectifier inverter-equipped shovels will result in lower energy consumption due to a reduction in machine losses from approximately 10% for the normal Ward Leonard system to approximately 3% for the inverter system. In addition, shovel availability will be increased due to the reduced maintenance required by the solid-state equipment relative to rotating machinery. The reduced losses and maintenance level of the rectifier inverter shovels is expected to more than offset any additional capital costs involved.

#### 10.3.2.2.2 Voltage Regulation

The start-up of large motors results in the imposition of a large reactive power demand upon the transmission network and, accordingly, a significant drop in voltage at the terminals of the motors. These voltage drops can be compensated for by the use of appropriate equipment comprising either synchronous or static compensators. At Hat Creek, the use of static capacitors on individual motor loads would be restricted to the pre-production years, when limited construction power is available for operation of the pit and the Houth Meadows Waste Dump.

No voltage regulation problems are foreseen at the time that the main 60 kV lines are installed to the powerhouse.

#### 10.3.2.2.3 Estimated Annual Power Demands and Energy Consumption

Table 10-3 shows the estimated mine loads for peak consumption during Years 22 to 25, inclusive. The three types of load specified on the table are defined as follows:

##### Connected Load

This is the sum of all equipment and motor loads installed in the plant or site.

### Typical Load

This is the load most likely to be exerted upon the power supply system during normal production periods.

### Annual Average Load

Although this load never actually applied to the power system, this is an estimate of the annual energy consumption presented as a continuous load.

The estimated annual power demands and energy consumption for Years 2 to 35, inclusive, are listed on Table 10-4.

#### 10.3.2.3 Network Design Criteria

The proposed electrical system is shown in Figure 10-7 and has been developed on the basis of the following criteria:

- (1) Two mine feeders will be available from B.C. Hydro at the Hat Creek Generating Station's 60 kV busbar; each of these feeders are capable of supplying the total mining load, make-up water for the generating station, and ash disposal pumping requirements;
- (2) Construction power at 60 kV will be available from the existing powerline at the junction of Highway 12 and the present Hat Creek road;
- (3) Development of the major supply network to the open pit and to Houth Meadows and Medicine Creek Waste Dumps will take place over a period of 14 years. Primary distribution network throughout the complex will be rated at 60 kV, while supplies to shovels, conveyors, etc., will be rated at 6.9 kV. Auxiliary mine equipment, pumps, lighting, and air compressors, together with internal systems for auxiliary buildings, will be 600/347 v, while other building voltages will be 120 v single-phase, where desirable. Transformers will be selected to be interchangeable within standard ratings;
- (4) The rating of the apparatus, transformer impedances, line and cable conductor, etc., will be sized such that the voltage fluctuation at the terminals of a shovel will not exceed +10%, -5% under the worst operating conditions. Voltage regulation of the 60 kV power supply from the Hat Creek Generating Station is not expected to exceed ±5%;

- (5) The electrical power network for the mine has been designed based on the overall economic optimization of both the remote power loads from the generating station and the remote mining loads, under the control of a single operating entity;
- (6) Power distribution within the pit and waste dump areas will be by portable sub-stations and power cables. The portable power cables will be generally TYPE SHD-GC, three-conductor with two ground and one ground check conductor terminated at their extremities with plug and socket-type couplers. The portable sub-stations will be of one common design and will consist of the following elements:
- A portable high voltage (60 kV) switching unit;
  - A skid-mounted 4 MVA 60 kV/6.9 kV 3 PH., 60 Hz oil-filled transformer;
  - A portable 6.9 kV totally enclosed switching unit complete with three feeder circuits and female cable couplers;
  - A portable low-voltage 600/347 v switching and distribution unit complete with 600 v female cable couplers, as well as one 1 MVA 6.9 kV/600/347 v 3 PH., 60 Hz oil-filled transformer;

(Figure 10-8 shows a typical in-pit arrangement of portable sub-stations and cables.)

- (7) Fixed loads at permanent locations will be supplied from the 60 kV powerlines via permanent sub-stations similar to the one shown in Figure 10-9; this drawing depicts a typical permanent sub-station which is designed to tap on to a 60 kV transmission line, and which can be equipped with either one or two step-down transformers and 6.9 kV switching units.

#### 10.3.2.4 System Description

##### 10.3.2.4.1 General

In assessing the sizing of lines, transformers, etc., recognition has been made of diversity in operation of the various items

of plant. Transformer ratings have been established from consideration of both the thermal loading and voltage drop during start-up of the motor loads, and the standardization of the MVA ratings.

Utilization voltages are based on economic optimization, technical desirability, and standardization of all portable sub-stations for the highest degree of interchangeability and reliability. For the portable sub-stations, 6.9 kV was selected, as this is the preferred shovel voltage.

The initial supply network to the mine up to and including Year 13, will consist of two 60 kV lines from the sub-station at the generating station. The first parallels the coal conveyor and the Houth Meadows Waste Material Conveyor, and is routed so as to encompass the West side of the pit. The second 60 kV line runs from the vicinity of the ash disposal pond adjacent to the extreme Northern boundary of the Medicine Creek Waste Dump, then parallels the Medicine Creek Waste Material Conveyor right-of-way so as to encompass the East side of the pit.

#### 10.3.2.4.2 Pit Area

The in-pit supply network will consist of eight portable skid-mounted 60 kV/6.9 kV sub-stations, i.e., one per shovel plus one spare. The spare unit will be used to prepare for shovel relocations. Eight low-voltage portable skid-mounted 6.9 kV/600 v sub-stations, one per shovel plus one spare, will also be provided. All in-pit cabling will be via 6.9 kV or 600 v trailing cables, depending on the equipment being served.

#### 10.3.2.4.3 Houth Meadows Waste Dump

The Houth Meadows Supply Network will initially consist of one 8 MVA permanent 60 kV/6.9 kV sub-station to feed the overland waste conveyors. In Year 4, this sub-station will be extended to 2 x 8 MVA to accommodate the increased loading of these conveyors. With the opening of the Medicine Creek Waste Dump in Year 16, the sub-station can be reduced to 1 x 8 MVA.

Power supply to the transfer conveyors and spreaders will be provided by portable skid-mounted 60 kV/6.9 kV sub-stations supplemented by portable skid-mounted 6.9 kV/600 v sub-stations where low-voltage 600 v loads are present. The number of complete portable sub-stations varies according to the following schedule:

Years -2 to 8	3 units
Years 8 to 14	4 units
Years 14 to 21	5 units
Years 21 to 35	4 units

All distribution within the dump will be via 6.9 kV or 600 v trailing cables, depending on the equipment being served.

#### 10.3.2.4.4 Medicine Creek Waste Dump

The Medicine Creek Supply Network will comprise two overland conveyor sub-stations, each consisting of one 8 MVA transformer rated at 60 kV/6.9 kV. A maximum of two complete portable skid-mounted 60 kV/6.9 kV. A maximum of two complete, portable skid-mounted 60 kV/6.9 kV sub-stations, each supplemented by a portable skid-mounted 6.9 kV/600 v sub-station, will be required and will be installed in Year 15. The schedule of complete portable sub-stations is as follows:

Years 15 to 17	1 unit
Year 18	2 units
Years 18 to 24	1 unit
Years 24 to 27	2 units
Years 27 to 35	1 unit

All distribution within the dump will be via 6.9 kV or 600 v trailing cables, depending on the equipment being served.

#### 10.3.2.4.5 Mine Service Facilities

All service and office building areas are planned to be supplied by underground 6.9 kV cables from the Truck Unloading Station No. 1 permanent sub-station. Supply provisions will be made for the following facilities:

- Maintenance complex;
- Administration Building;
- Mine Dry;
- Rubber repair shops;
- Mine Services Building.

Other minor loads, such as those for the laboratory and gate house, will be supplied from an adjacent service or office building by 600 v underground cables.

#### 10.3.2.4.6 Crushing/Blending Plant

A 2 x 8 MVA sub-station will supply a common 6.9 kV service to the crusher building, blending area, and Truck Unloading Station No. 1, to be built in Year 1. This sub-station will supply most of the power requirements of the coal-crushing and blending plant. A separate 16 MVA sub-station would be required to supply a coal-washing plant, should one be installed.

#### 10.3.2.4.7 Reliability

The 60 kV transmission lines have been physically located to provide maximum reliability for all the major electric loads. It will be possible to operate the network as a ring main system for the pit and part of the Medicine Creek Waste Dump. However, the Houth Meadows Waste Dump 60 kV network will operate as a radial feeder.



Should failure of an 8 MVA 60 kV transformer occur, requiring several months for repair, it is intended that one of the 8 MVA transformers installed at the Truck Unloading Station No. 1 or No. 2 would be used. Since these two stations are not expected to be simultaneously operating at maximum capacity due to the yearly change in mining activity, one transformer should always be available for use as a temporary replacement elsewhere.

10.3.2.4.8      Construction Power

The erection of special construction powerlines is not required, with the exception of:

- (1) A short 60 kV line connecting the most Easterly leg of the Houth Meadows Waste Dump line to the existing 60 kV circuit at the junction of Highway 12 and the Hat Creek road; and
- (2) A short 60 kV line connecting Truck Unloading Station No. 1 to the line supplying the crusher sub-station.

By installation early in the construction period of these two short temporary 60 kV lines, about 2 km of 60 kV permanent transmission lines, and Hopper Station No. 1 sub-station, an adequate power supply at 6.9 kV can be realized. In general, the construction power supply will be provided by the early installation of the permanent electrical supply equipment.

TABLE 10-1

Estimated Mine Water Requirements

	Daily Average (1) m <sup>3</sup> /day	Supply Source	
		Construction	Operation
<u>Potable</u>			
Mine Dry	140	Wells	Powerplant
Service Buildings and Laboratories	90	Wells	Powerplant
Revegetation Nursery	<u>5</u>	Wells	Powerplant
Total Potable	<u>235</u>	Wells	Powerplant
<u>Irrigation</u>			
Mine Services Area	120	--	Pit Rim Reservoir
Nursery	<u>500</u>		
Total Irrigation	<u>620</u> <sup>(2)</sup>	--	Pit Rim Reservoir
<u>Dust Control</u>	2,000	--	Leachate Storage Lagoon
TOTAL REQUIREMENTS	<u>2,855</u>		
<u>Fire Protection (Storage)</u>	1,000 m <sup>3</sup>	Wells	Powerplant

Notes: (1) based on Year 35  
(2) Summer use only

Source: CMJV Vol. IV Section 4

**TABLE 10-2**

Water Quality Data  
Hat Creek Project Mining Feasibility Report 1978

Water Source	Hat Creek Surface Water	Thompson River Surface Water	Hat Creek Valley Groundwater
PARAMETER (mg/L)	System Mean	System Mean	One Sample Well V78-72
<b>CATIONS - Trace Metals</b>			
Aluminum (Al)	< 0.010	< 0.017	-
Arsenic (As)	< 0.005	< 0.005	-
Cadmium (Cd)	< 0.005	< 0.005	-
Chromium (Cr)	< 0.010	< 0.010	-
Copper (Cu)	< 0.005	< 0.005	< 0.03
Iron (Fe)	< 0.026	< 0.022	-
Lead (Pb)	< 0.010	< 0.010	-
Mercury (Hg)	< 0.00040	< 0.00034	-
Molybdenum (Mo)	< 0.020	< 0.020	-
Selenium (Se)	< 0.003	< 0.003	-
Vanadium (V)	< 0.005	< 0.005	-
Zinc (Zn)	< 0.007	0.017	-
Manganese (Mn)	-	-	0.05
<b>CATIONS - Alkali Earths &amp; Metals</b>			
Calcium (Ca)	57	11	59.8
Lithium (Li)	0.002	< 0.001	-
Magnesium (Mg)	19	2.3	59.1
Potassium (K)	4.0	0.63	24.5
Sodium (Na)	20/23	3.3	220
Strontium (Sr)	0.32	0.055	-
<b>ANIONS - General</b>			
Boron (B)	0.10	< 0.10	-
Chloride (Cl)	1.1	1.6	8
Fluoride (F)	0.16	0.11	-
Sulfate (SO <sub>4</sub> )	54	7.6	392
<b>ANIONS - Nutrients</b>			
Total Kjeldahl Nitrogen (N)	0.19	0.08	-
Nitrate Nitrogen (NO <sub>3</sub> -N)	< 0.05	< 0.07	-
Nitrite Nitrogen (NO <sub>2</sub> -N)	< 0.002	< 0.002	-
Total Orthophosphate Phosphorus (P)	0.043	0.020	-
<b>ORGANIC, NONIONIC &amp; CALCULATED VALUES</b>			
COD	21	21	-
TOC	9	3	-
Phenol	< 0.002	< 0.002	-
Total Hardness (CaCO <sub>3</sub> )	224	38	392
Total Alkalinity (CaCO <sub>3</sub> )	226	35	760
<b>PHYSICAL DATA</b>			
pH (units)	8.4	7.8	8.2
Specific Conductance (umhos/cm @ 25 <sup>o</sup> )	489	93	1470
True Color (Pt-Co Units)	12	9	-
Turbidity (NTU)	1.5	0.81	-
Temperature (°C)	6.6	8.0	-
<b>PHYSICAL DATA - Residues</b>			
Total Residue	348	77	-
Filterable Residue	342	74	1230
Nonfilterable Residue	6	3	-
Fixed Total Residue	281	50	-
Fixed Filterable Residue	278	49	-
Fixed Nonfilterable Residue	4	2	-
<b>BIOCHEMICAL, DISSOLVED GASES &amp; RELATED MEASUREMENTS</b>			
BOD	< 1	< 1	-
D.O.	11.1	11.1	-
Data Sources:	Beak, 1978	Beak, 1978	H.A. Simons, 1978

TABLE 10-3

Total Estimated Mine Load During Peak Years  
Hat Creek Project Mining Feasibility Report 1978

<u>Requirement</u>	<u>Connected Load (kW)</u>	<u>Typical Load (kW)</u>	<u>Annual Average Load (kW)</u>
<u>Out-of-Pit Loads</u>			
Conveyor Load	53,500	24,382	15,600
Maintenance Complex	2,760	1,681	1,320
Mine Dry Complex	841	427	363
Rubber Repair Building	359	165	125
Mine Service Building	805	383	278
Administration Building	<u>644</u>	<u>349</u>	<u>178</u>
	58,909	27,387	21,618
<u>In-Pit Loads</u>			
9 Shovel Sub-stations (1 spare)	13,500	8,142	2,714
Pumping and Miscellaneous	<u>455</u>	<u>180</u>	<u>126</u>
	13,955	8,322	2,840
Total	<u><u>72,864</u></u>	<u><u>35,709</u></u>	<u><u>24,458</u></u>

TABLE 10-4

Estimated Annual Load and Energy Demands  
Hat Creek Project Mining Feasibility Report 1978

Year	Average Annual Load (kW)	Typical Load (kW)	Annual Energy (MW hours)
-2	2,625	3,833	22,988
-1	13,799	20,117	120,702
1	18,836	27,501	165,006
2	19,971	29,158	174,948
3	20,999	30,659	183,954
4	22,448	32,774	196,644
5	22,089	32,250	193,500
6	23,853	34,825	208,950
7	23,853	34,825	208,950
8	23,853	34,825	208,950
9	23,853	34,825	208,950
10	23,853	34,825	208,950
11	21,313	31,117	186,702
12	22,940	33,492	200,952
13	22,940	33,492	200,952
14	23,933	34,942	209,652
15	23,933	34,942	209,652
16	24,458	35,709	208,254
17	24,458	35,709	208,254
18	24,458	35,709	208,254
19	24,458	35,709	208,254
20	24,458	35,709	208,254
21	23,647	34,525	634,525
22	23,647	34,525	634,525
23	23,647	34,525	634,525
24	23,647	34,525	634,525
25	23,647	34,525	634,525
26	21,626	31,574	189,446
27	20,240	29,550	177,300
28	19,829	28,950	173,700
29	19,829	28,950	173,700
30	19,829	28,950	173,700
31	19,829	28,950	173,700
32	19,829	28,950	173,700
33	19,829	28,950	173,700
34	19,829	28,950	173,700
35	19,829	28,950	173,700

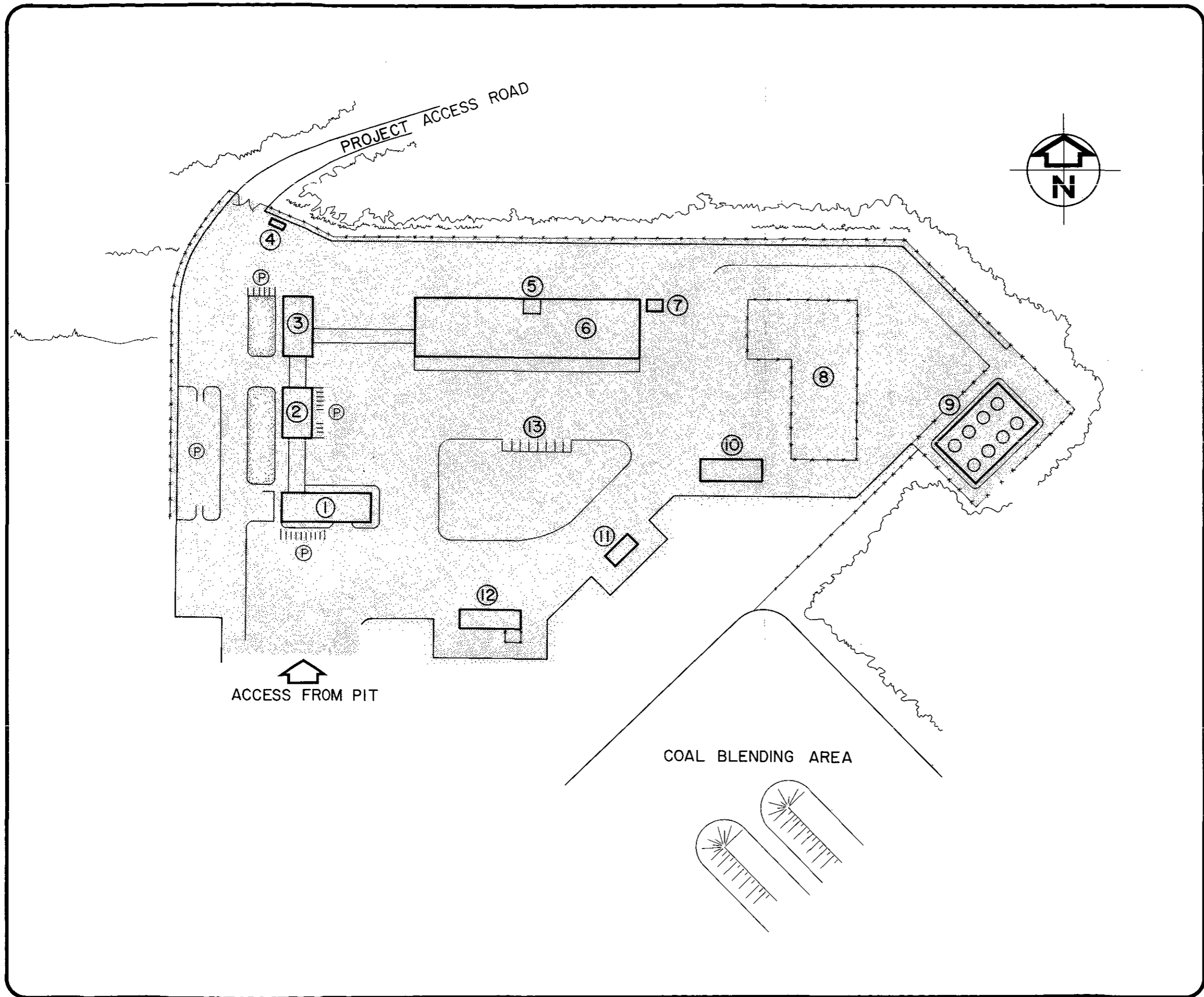

**LEGEND**

- ① MINE DRY
- ② LABORATORY
- ③ ADMINISTRATION BUILDING
- ④ GATEHOUSE
- ⑤ FIRE TRUCK/AMBULANCE GARAGE
- ⑥ MAINTENANCE COMPLEX & WAREHOUSE
- ⑦ LUBE STORAGE BUILDING
- ⑧ FENCED STORAGE AREA
- ⑨ FUEL STORAGE & DISPENSING AREA
- ⑩ MINE SERVICES BUILDING
- ⑪ FIELD MAINTENANCE CENTRE
- ⑫ RUBBER REPAIR SHOP
- ⑬ TRUCK READY LINE
- Ⓟ PARKING

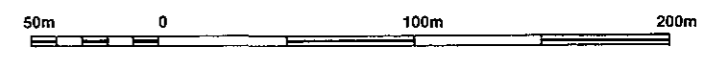

HAT CREEK PROJECT

FIGURE 10-1

**GENERAL ARRANGEMENT  
MINE SERVICES AREA**

SOURCE: British Columbia Hydro and Power Authority

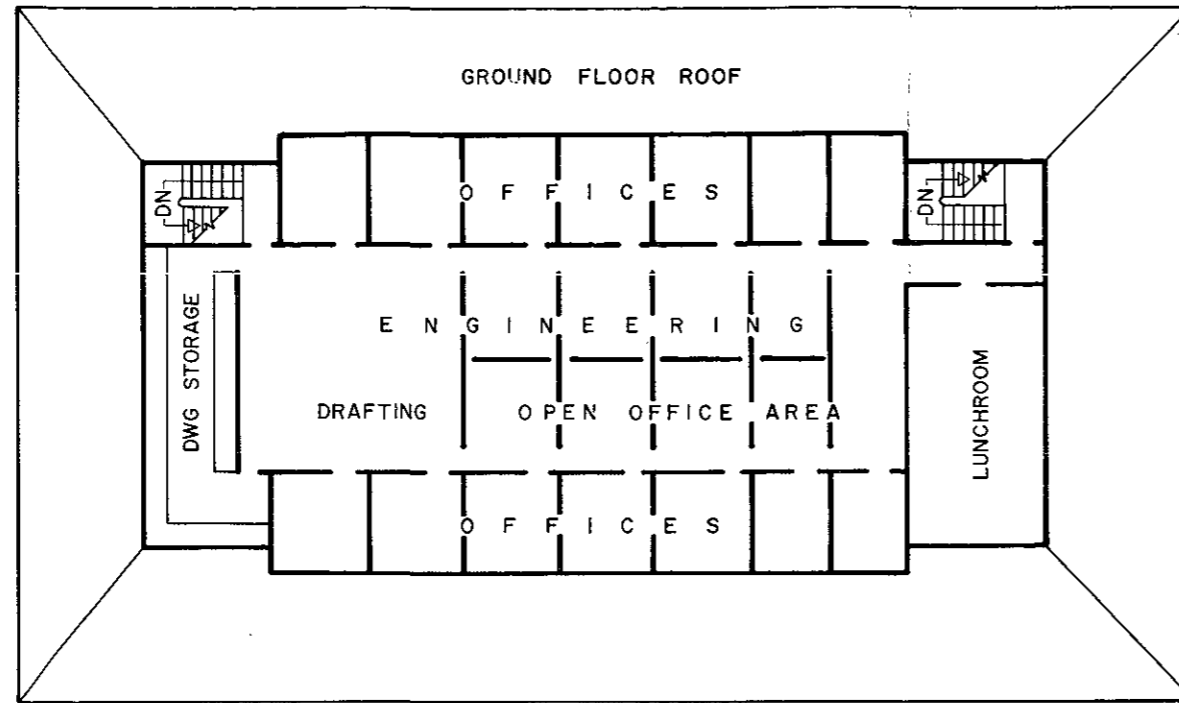

SECOND FLOOR PLAN

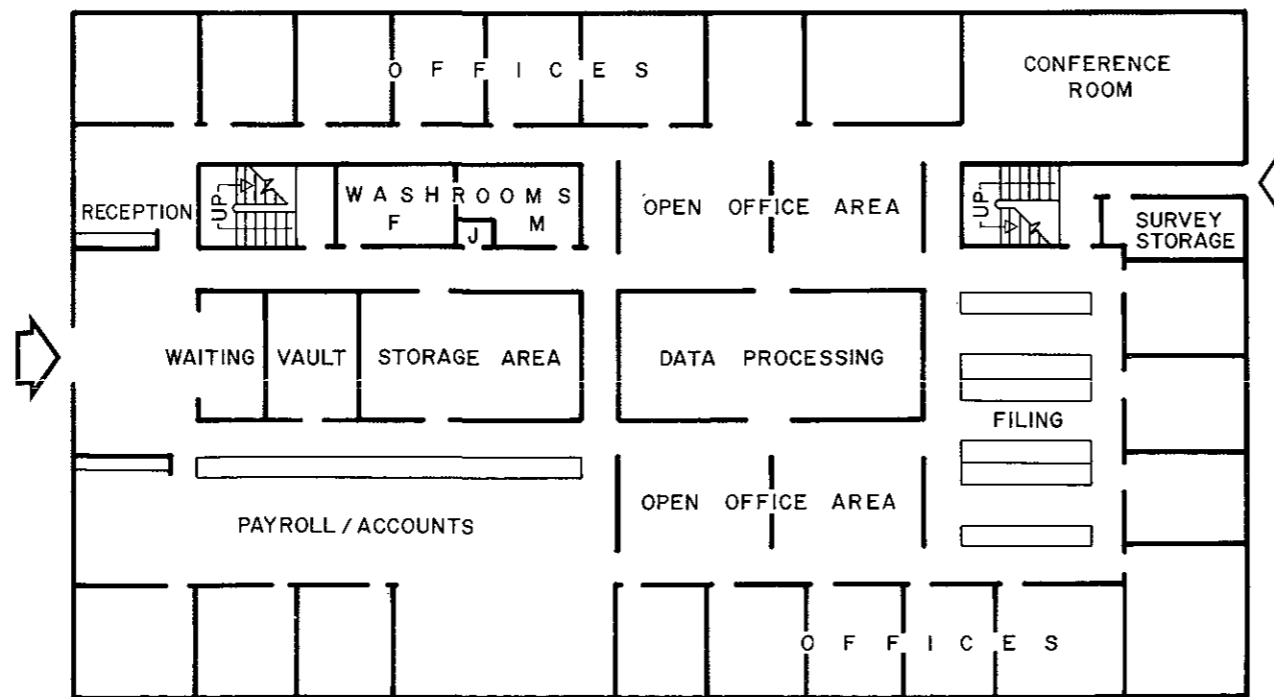

GROUND FLOOR PLAN

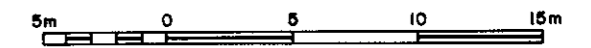

HAT CREEK PROJECT  
**FIGURE 10-2**  
**ADMINISTRATION BUILDING**

SOURCE: Cominco-Monenco Joint Venture

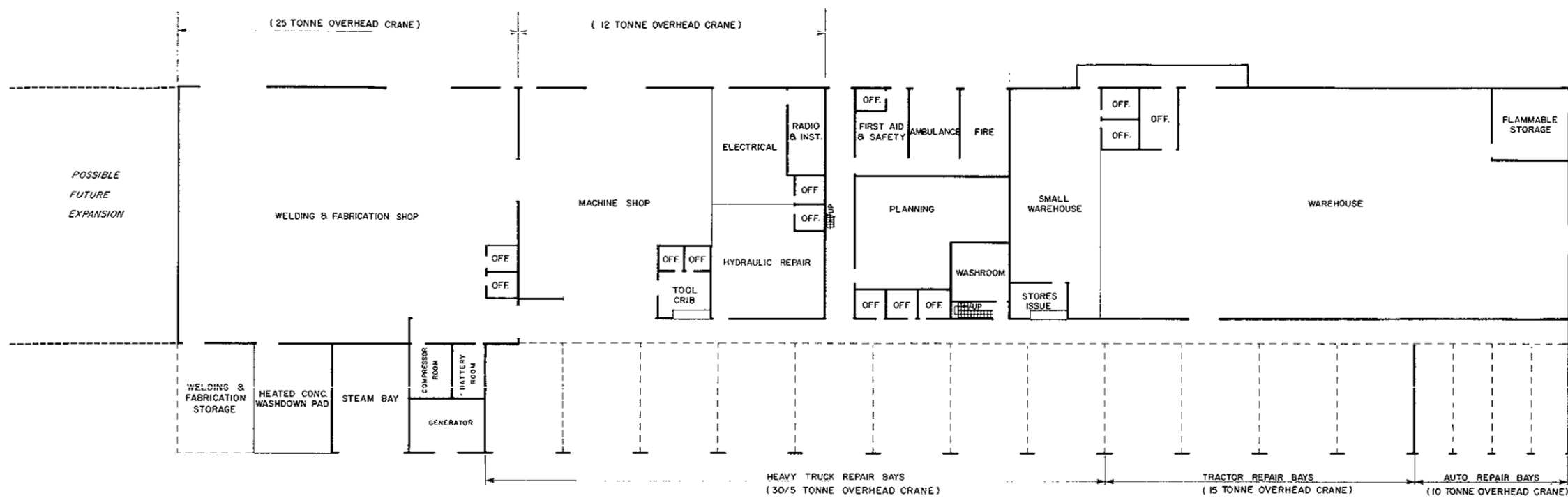

GROUND FLOOR PLAN

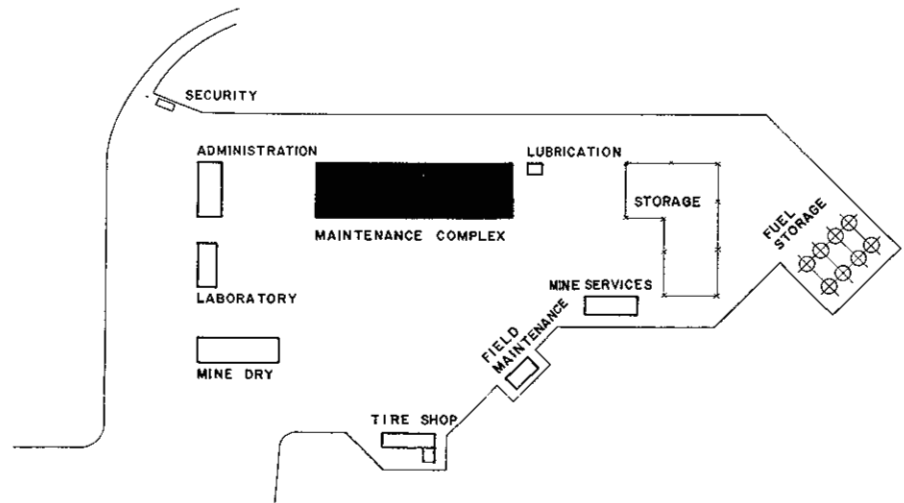

KEY PLAN  
50 0 50 100 150 m

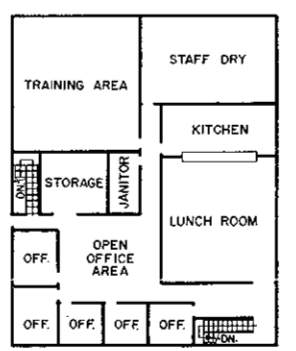

SECOND FLOOR PLAN

5 0 5 10 15 20 m

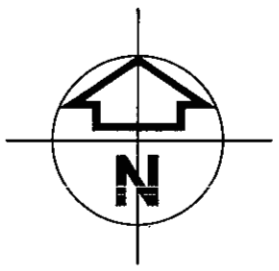

HAT CREEK PROJECT  
FIGURE 10-3  
MAINTENANCE COMPLEX

SOURCE: Cominco-Monenco Joint Venture



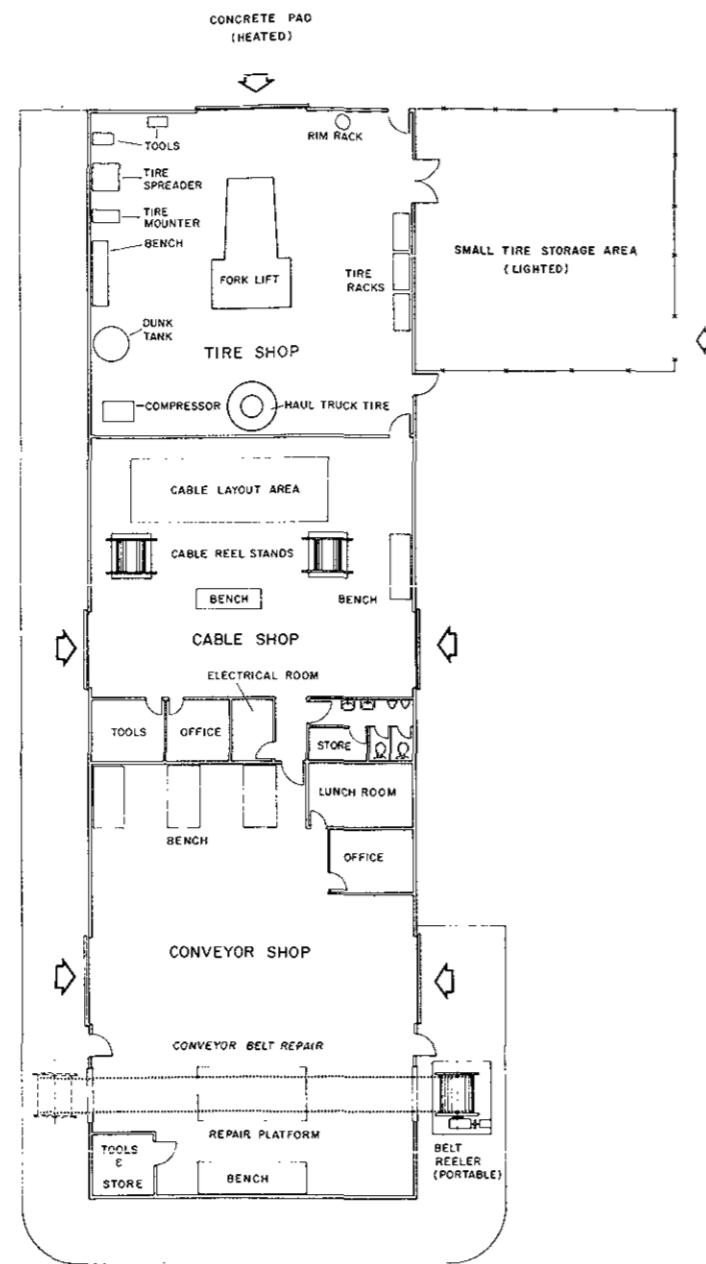

RUBBER REPAIR SHOP

0 1 2 3 4 5 6 7 8 9 10m

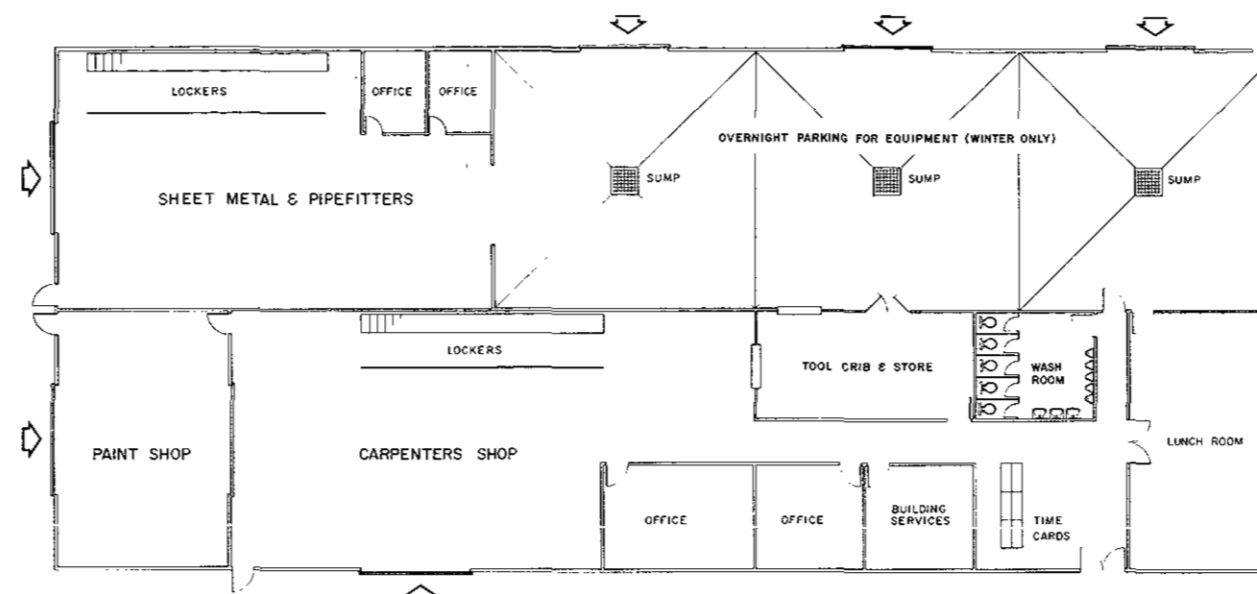

MINE SERVICES BUILDING

0 1 2 3 4 5 6 7 8 9 10m

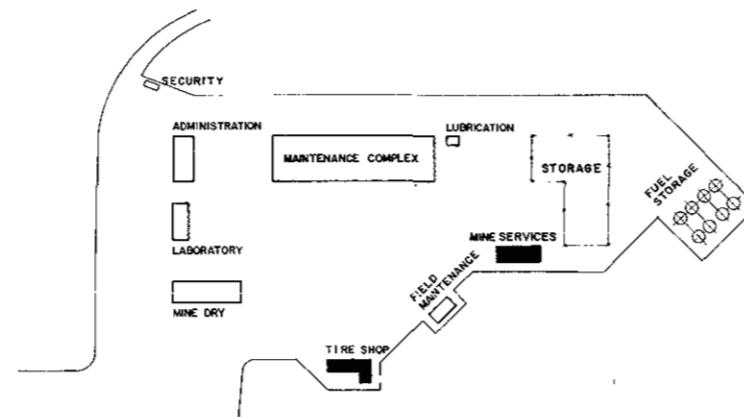

KEY PLAN

50 0 50 100 150m

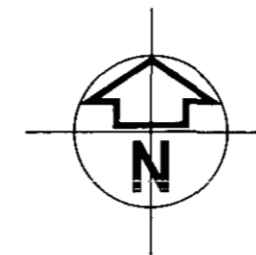

HAT CREEK PROJECT

FIGURE 10-4

**Mine Services Building and Rubber Repair Shop**

SOURCE: Cominco-Monenco Joint Venture

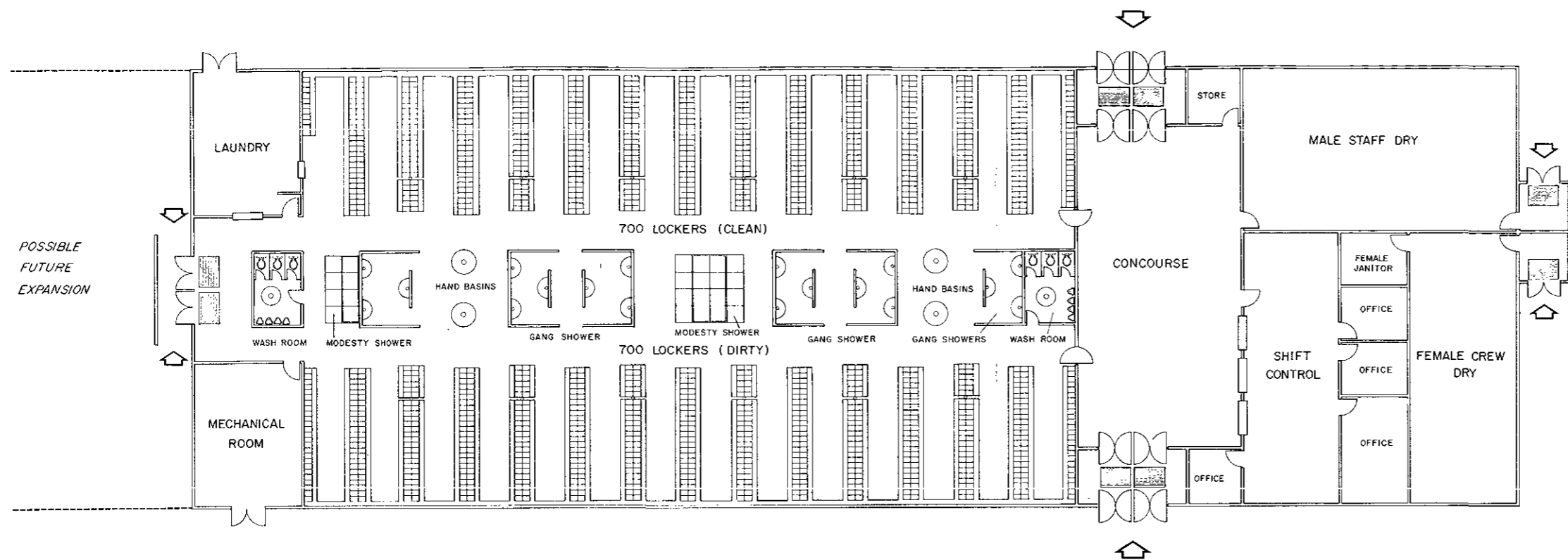

FLOOR PLAN

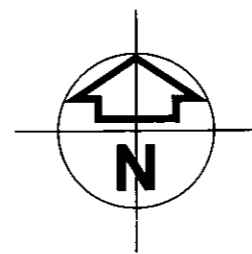
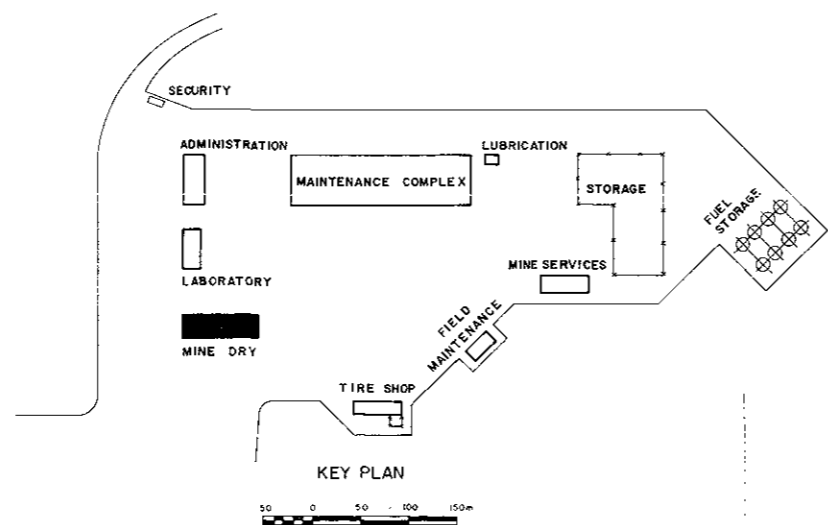
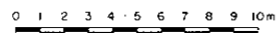

HAT CREEK PROJECT

FIGURE 10-5

MINE DRY

SOURCE: Cominco-Monenco Joint Venture

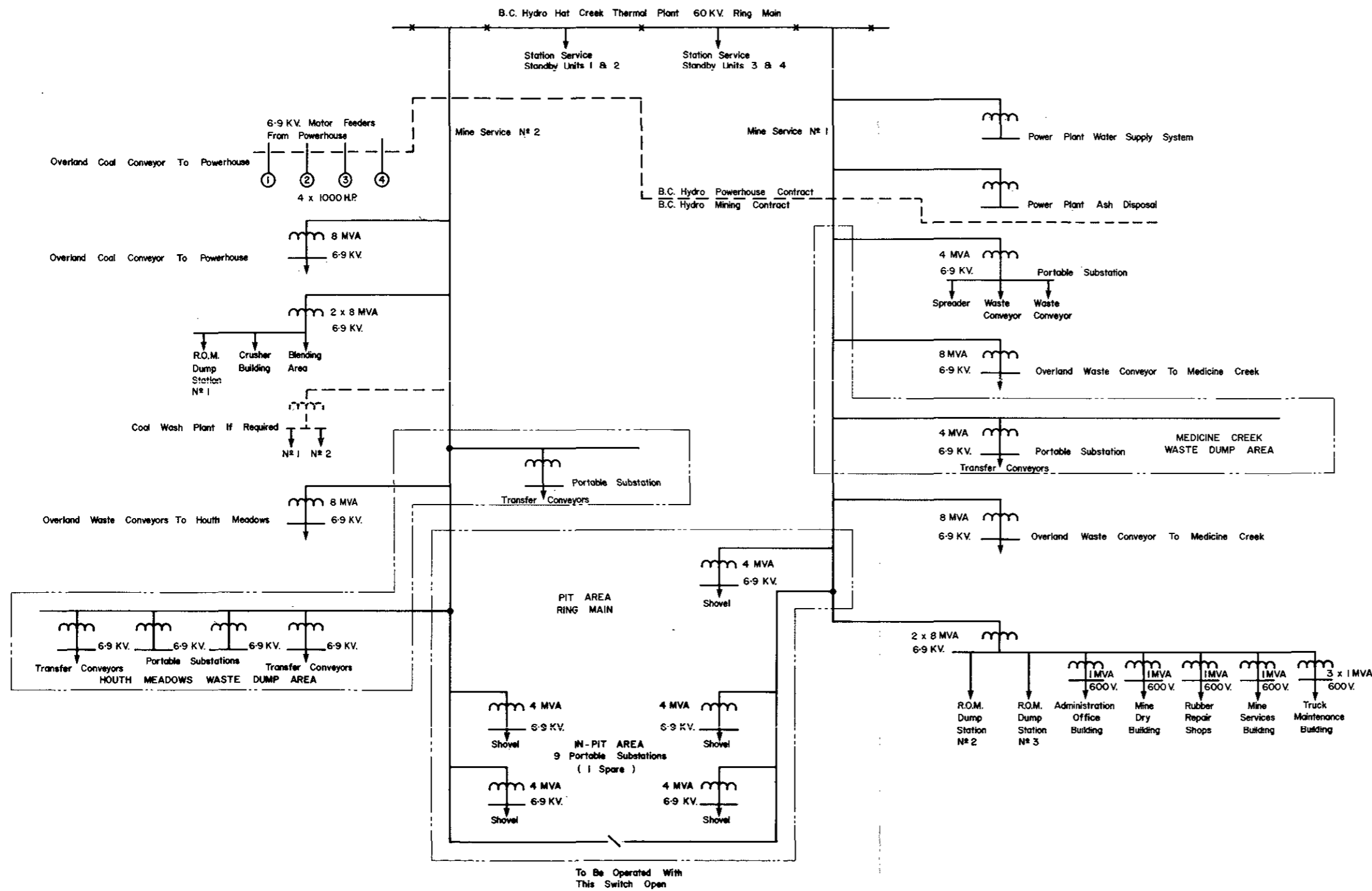

HAT CREEK PROJECT  
 FIGURE 10-6  
 MINE POWER  
 DISTRIBUTION NETWORK

SOURCE: Cominco-Monenco Joint Venture

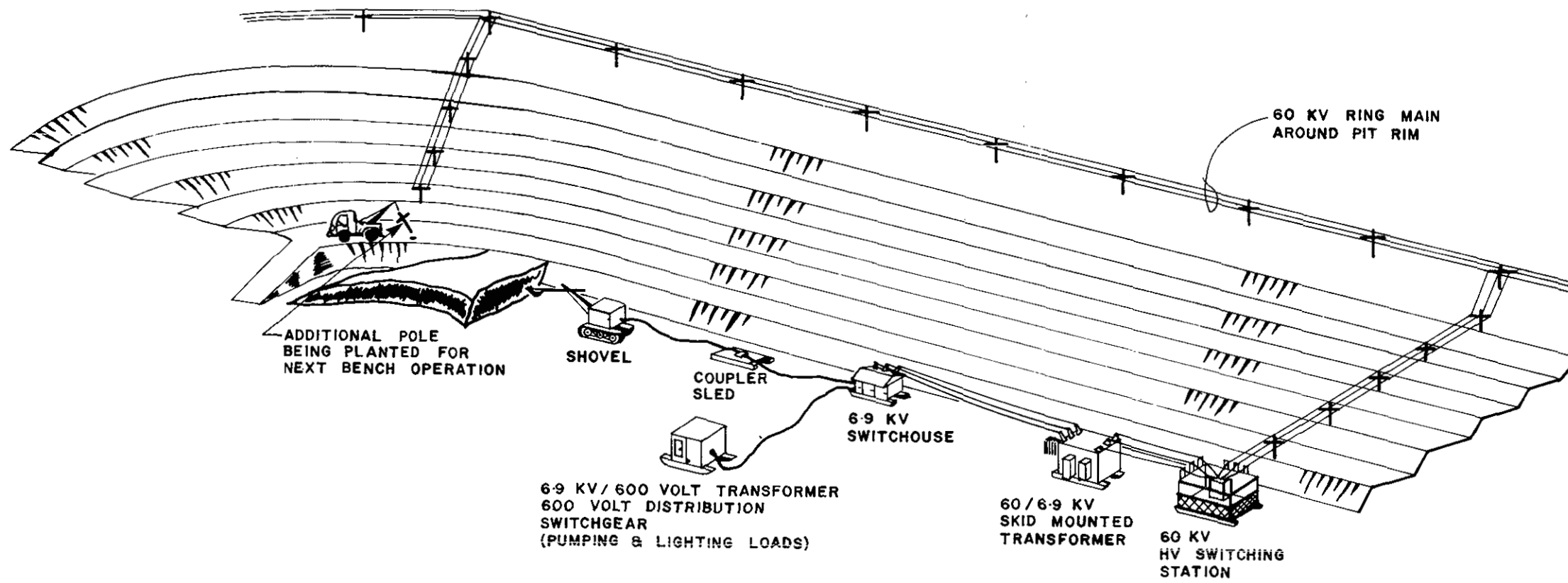

HAT CREEK PROJECT  
 FIGURE 10-7  
 TYPICAL  
 PORTABLE SUBSTATION LAYOUT

SOURCE: Cominco-Monenco Joint Venture

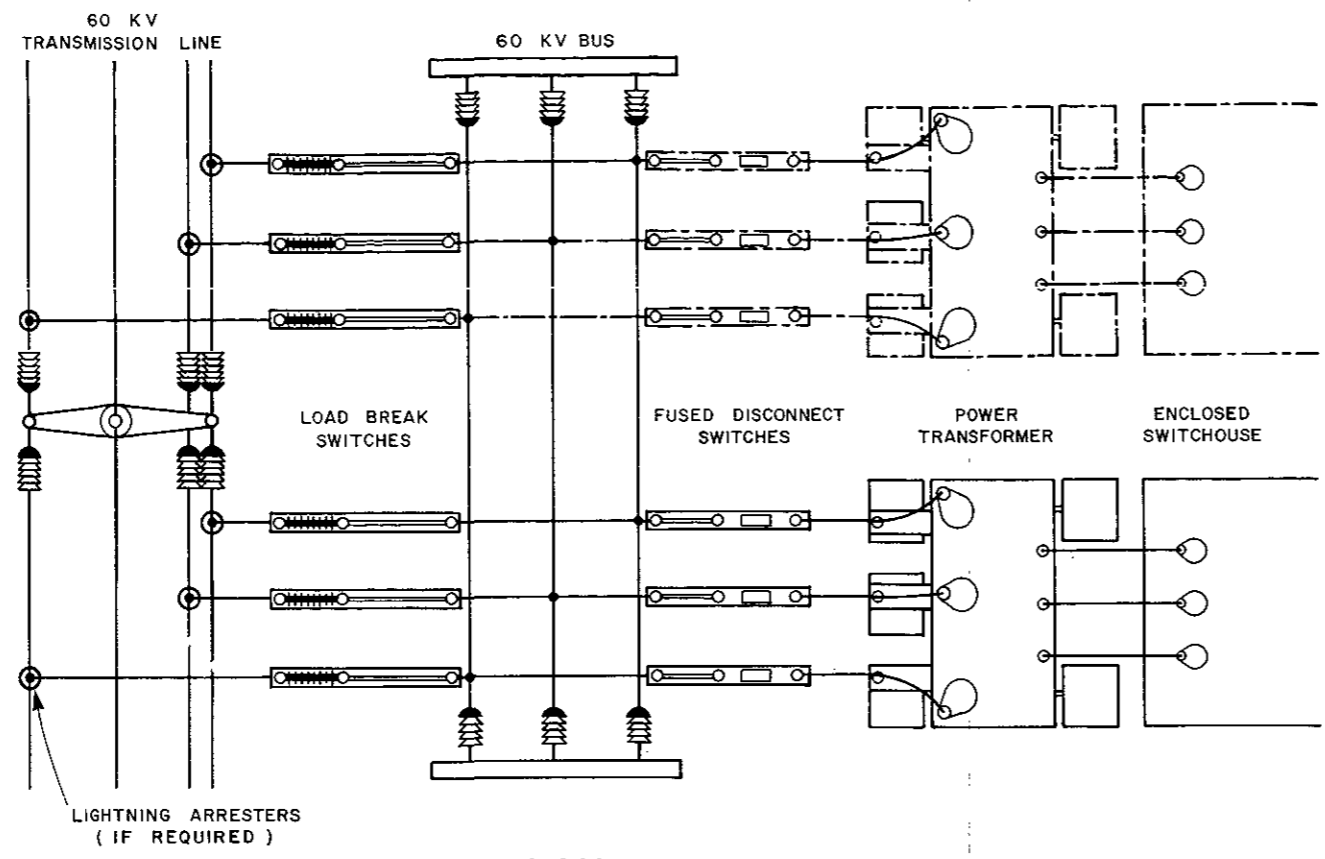

PLAN

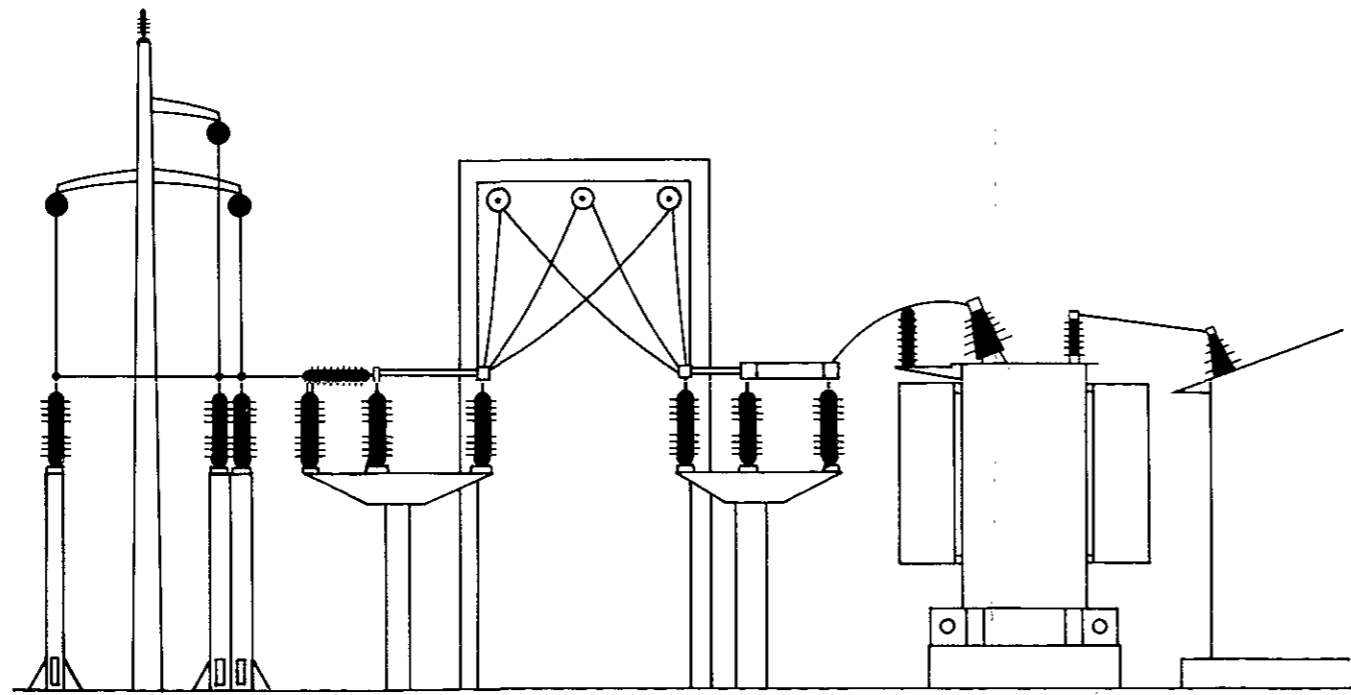

ELEVATION

HAT CREEK PROJECT  
 FIGURE 10-8  
 TYPICAL PERMANENT  
 SUBSTATION LAYOUT

SOURCE: Cominco-Monenco Joint Venture

11	<u>ENVIRONMENTAL PROTECTION</u>	<u>Page</u>
11.1	Introduction	1
11.2	Dust	2
11.3	Noise	3
11.4	Mine Drainage and Water Quality	4
11.5	Land Reclamation	5
11.5.1	On-site Reclamation Testing	5
11.5.2	Waste Dumps and Embankments	8
11.5.3	Material Storage Areas After Abandonment	9
11.5.4	Transportation Corridors	9
11.5.5	Support Facilities	10
11.5.6	The Open Pit After Abandonment	10
11.5.7	Disturbances and Possible Resource Losses	11
11.6	Other Measures	12
11.6.1	Spontaneous Combustion	12
11.6.2	Environmental Services Complex	12
11.6.3	Monitoring	12
11.6.4	Archaeology	13
11.7	Costs	14

No.

LIST OF TABLES

Page

11-1	Estimate of Areas Disturbed and Reclaimed by Year 35 and Year 45	15
------	---	----

LIST OF FIGURES

11-1	Map of Reclamation by Year 45	16
------	-------------------------------	----

## SECTION 11

### ENVIRONMENTAL PROTECTION

#### 11.1 INTRODUCTION

The project area is situated within the Hat Creek drainage basin. Several small creeks, Medicine, Finney, Ambusten, and Houth, drain into Hat Creek, which flows North and then East to the Bonaparte River, from where it joins the Thompson River System just North of Ashcroft. The water bodies of significance in the general project area are Aleece Lake and Finney Lake.

The regional climate is classified as continental, and is typified by long, cold winters and short, warm summers. Semi-arid conditions prevail; average precipitation is 317 mm/a, of which about half falls as snow. Winds behave according to the mountain/valley topography and are channelled predominantly upslope from the North to the South and South-West during the day, and the reverse at night.

The objective of the Reclamation and Environmental Protection Plan is to protect land, water, and air during the construction and operation of the mine. After the mine closes, it is planned, within practical limits, to restore the land to the same condition as it was before mining started. While the mine is being built and operated, the control of drainage will be of paramount importance in order to protect the aquatic environment downstream. The same considerations apply to the control of noise and dust. It is equally important to ensure that any measures taken to replant disturbed land should be continued for however long it may take to restore the land to a self-sustaining stable and useful condition.

The plan makes provision for both restoration and extended care under three major reclamation and environmental protection priorities:

- (1) Drainage control during and after mining;
- (2) The effective replanting of disturbed land areas; and
- (3) The development of a safe pit abandonment scheme.



Initial studies of the air quality impacts of the mine indicated a potentially serious problem with dust. As a result, B.C. Hydro instructed the Mining Consultants (CMJV) to examine the problem and to devise suitable measures to ensure that the B.C. Pollution Control Branch guidelines for total suspended particulates of  $60 \mu\text{g}/\text{m}^3$  and  $150 \mu\text{g}/\text{m}^3$  for annual and 24-hour averages respectively, could be met. Results of this work, endorsed by the original air quality consultants, indicated that dust was indeed controllable, provided certain actions were undertaken. These proposed dust control measures, reviewed and accepted by B.C. Hydro, include both design changes and operating factors, for example:

- Blending piles: The present blending area was moved from its original position where the present mine services facilities are located. In addition, the area would be constructed "into" the adjacent hill to an elevation of 930 m, a protective dike to 950 m would be constructed along the SW edge of the area, and the coal piles would be suitably contoured to reduce erosion. Stacking out would be carried out with a telescopic chute on the boom conveyor. An effective water spray system would be installed;
- The area stripped of surface soils will at all times be minimized to reduce erosion potential. In addition, stripping would be continued until non-friable (i.e. low-dusting potential) material was reached if possible;
- Binding agents would be used to control erosion where appropriate;
- Areas that would remain stripped for extended periods of time would be revegetated.

NOISE

Existing sound levels have been measured and compared with those likely to arise from operation of the mine. Findings show that the Hat Creek Valley may be affected by noise from the project, though not significantly.

Present noise levels in the valley vary from about 30 to 40 dBA in the areas away from Highway 12. Adjacent to the highway, noise levels range from 44 to 51 dBA. By comparison, a soft whisper would produce a sound level of about 30 dBA, and a quiet wind through the trees would be around 50 dBA.

Noise from construction would, of course, be transitory, whereas noise from the mine operation essentially constant throughout the mine's productive life. The latter would stem principally from heavy equipment moving in and around the pit, with intermittent additional noise from the coal stacker-reclaimer, conveyors and crushers. Only two of the five Hat Creek ranches are expected to be affected by construction activity noise. Maximum noise levels on these ranches would reach 47 dBA which is close to the 45 dBA typically set as a nighttime level by many communities.

The South-Western portion of the Bonaparte Indian Reserve may be affected by mining and coal preparation noise. The area involved contains at present one dwelling with four to six residents. The two ranches nearest to the pit might experience intermittent noise levels up to 63 dBA; the next two, levels of between 45 and 49 dBA; and the two furthest away, levels of 41 to 42 dBA. As the natural background level is 35 to 40 dBA, the occasional level of noise from the mining operation is not expected to cause annoyance to anyone reasonably disposed.

Drainage measures in so far as they affect reclamation may be summarized by noting that all lagoons, diversions, ditches, and reservoirs linked with wetland and riparian habitats will be left intact and revegetated wherever possible within the constraints imposed by mining. Drainage control structures will be grass-seeded, and, where erosion or flow capacity is not involved, with a mixture of shrubs, trees, and grasses.

Laboratory and field tests on materials which would be encountered during mining have been run to determine the concentrations of leachable materials. Based on these data and the water quality and hydrology of the water bodies to be affected by this project, the main drainage plan has been devised. Details are provided in Section 6. Essential elements of the plan are:

- (1) All water suitable for simple diversion without any form of treatment, such as Hat Creek, would be redirected around the project and returned to its natural downstream water course;
- (2) Run-off contaminated with suspended solid material would undergo sedimentation to reduce the concentration of suspended solids to less than 50 mg/L;
- (3) All water of unsuitable quality for discharge would be collected in leachate pond and disposed of on site by re-use in dust control or by spray evaporation on waste dumps.

This drainage scheme would remain in service during the 10-year post-abandonment period to ensure that water quality values downstream of the project would be maintained. The Hat Creek diversion scheme, headworks dam, and the pit rim dam would be developed to re-establish a suitable wetland habitat in the early stages of the project. All drainage ditches would be revegetated to reduce suspended solids contamination.

11.5            LAND RECLAMATION

11.5.1        On-site Reclamation Testing

Both laboratory and on-site testing has been undertaken to determine the properties of the waste materials as growth media and to evaluate a variety of grass and legume species for revegetation at Hat Creek.

Initial laboratory (greenhouse) studies were followed by detailed on-site reclamation testing, making use of materials generated during the 1977 Bulk Sample Program. These latter tests have demonstrated most effectively that the revegetation of waste materials is feasible at Hat Creek consistent with B.C. Hydro proposed goals for reclamation. These may be summarized as follows:

- (1) Short-term goals    - Control of wind and water-borne erosion,  
                              - Aesthetics,  
                              - Stabilization of waste;
- (2) Long-term goals     - Self-sustaining vegetation,  
                              - Suitable end use - mixed agriculture and  
                                  wildlife.

The field tests comprised two major programs, one to examine the revegetation potential of slopes at different angles of repose, and the other to examine the different materials and determine their characteristics as growth media. All waste dumps associated with the 1977 Bulk Sample Program were also reseeded and provided facilities for further testing.

Slope Plots

Sloped revegetation test areas were constructed at Houth Meadows and Medicine Creek to examine the revegetation potential on typical embankment material, gravel at Houth Meadows and till at Medicine Creek, at slopes of 22°, 26°, and 30°. Half of each plot at Houth Meadows was covered with a thin layer of top soil. Aspect and altitude were selected to simulate as closely as possible climatic conditions to be encountered at the Medicine Creek and Houth Meadows waste disposal embankments. Both areas were hydro-seeded with a single seed mix in the Fall of 1977 and subsequently fertilised in the Spring of 1979.

Growth assessments were made during the latter part of the 1978 and 1979 growing seasons and the plots examined for signs of water-borne erosion. Results of these examinations have shown that there is essentially no difference in the success of vegetation establishment on the materials without topsoil at the three slope angles; in all cases growth was satisfactory with a good mix of grass and legume. Soil erosion due to runoff was not apparent even though several thunderstorms were experienced during this period. On the topsoil-treated plots at Houth Meadows, growth of seeded species was severely inhibited by the abundance and vigorous growth of weeds, the seeds of which were transported to the site in the topsoil.

From the results of these studies it is concluded that embankment slopes at Houth Meadows and at Medicine Creek could be constructed to stable and reclaimable slopes at least up to 30°.

#### Waste Material Test Plots

Seven waste materials were identified during the excavations of the 1977 Bulk Sample Program. Samples of these materials and of fly-ash from the Battle River Combustion Tests were set out in 15 m x 15 m x 1 m plots near Aleece Lake. Half of each plot was covered with a thin cover of topsoil and seeded in the Fall of 1977 with three different seed mixes of four species each. The soil characteristics of the mine waste materials suggest that they fall into essentially three categories, namely surficial materials such as colluvium (till), gravel, and baked clay; non-seam waste, gritstone (sandstone/claystone), and bentonitic clay; seam waste such as carbonaceous shale and waste coal. Each plot was fertilized during the Spring of both 1978 and 1979, based on recommendations from the B.C. Ministry of Agriculture following soils testing.

Detailed vegetation monitoring was carried out after one growing season to determine the success of revegetation based on seedling emergence and biomass production. A less comprehensive evaluation was conducted during 1979 to further monitor the progress of these test plots. The results of these studies may be summarized as follows:

- (1) Revegetation of surficial materials such as colluvium (till), gravel, and baked clay can be readily achieved. Further, these soils are suitable for reclamation purposes without the addition of topsoil. This result is noteworthy: in the case of colluvium, both biomass production and seedling emergence were lower on the topsoil-treated part of the plot. Plants were healthy and showed little sign of chlorosis. These results indicate that the materials selected for stripping, stockpiling and/or use as surface growth media, may comprise any of these surface materials, gravel, colluvium (till), baked clay, and topsoil, either separately or in combination. The implication here is clearly that the separate stripping of topsoil has been shown to be unjustified in the presence of suitable quantities of other surficial materials;

- (2) Revegetation of non-seam mine waste, gritstone (sandstone/claystone), and bentonitic clay proved to be more difficult to achieve in the short term. In addition to low emergence success, the biomass production of vegetation was poor; most plants exhibited leaf chlorosis. The physical and chemical properties of these soils contribute to poor soil structure under extreme conditions of moisture and nutrient imbalances.

The addition of topsoil proved beneficial although plants remained somewhat stunted. Subsequent 1979 observation showed some species of vegetation progressing well on the untreated gritstone. Nevertheless, it is considered that a surface capping of surficial material would be required to satisfactorily revegetate these waste materials;

- (3) Seam waste was the most difficult of all materials tested to vegetate. However, the chemical characteristics of these materials appear to be less of a deterrent than do their physical properties, particularly their dark colour resulting in excessive surface temperatures and the hydrophobic nature of the carbonaceous shale. A capping of surficial material would be required for satisfactory reclamation.

#### Waste Dumps

Waste material stockpiles from trenches A and B were seeded in late 1977. Piles at Trench C and unsatisfactory portions of the piles at Trench A were seeded in the Fall of 1978. Topsoil (15 cm) was applied to half of the uppermost dump at Trench A and to half of the dumps at Trench C. In addition, water retention furrows were constructed across the dump fall line in an attempt to improve moisture retention on the dump surface.

The results on these dumps confirm the results at Aleece Lake and the slope plots. Gravels and baked clay are readily revegetated, while bentonitic clay and gritstone show less success. Germination in topsoil was substantially less successful than germination in baked clay. Further, the dramatic growth in the water retention furrows constructed in bare carbonaceous shale and bentonitic clay clearly identifies the lack of moisture as a most important factor in revegetation at Hat Creek, where the annual precipitation totals only 317 mm.

#### Vegetation Species

In total 16 different species of grass and legume have been tested in these revegetation trials. The species were selected on the basis of their known characteristics and adaptation to the soils and climatic conditions at Hat Creek. To ensure that the species were both viable and available, only agronomic species were considered. Seed mixes of four and five species were devised and, in some instances, species were used individually.

Results of these field tests have identified several species which could be used for reclamation purposes at Hat Creek. Among the grass species the following perennial grasses show excellent potential: Crested Wheatgrass (Nordan), Streambank Wheatgrass (Sodar), Slender Wheatgrass, Tall Wheatgrass (Altar), and Smooth Bromegrass (Manchar). Fall ryegrass proved to be an excellent species for short-term (1 year) revegetation. However it is an annual, and because it is particularly tall-growing and vigorous, it is suspected of inhibiting the growth of other perennial species with which it was seeded. As a result, its use would be restricted to those occasions where short-term revegetation - for example, for dust control - is required.

Several legumes have been tested. Of these Alfalfa (Drylander) and Sainfoin (Melrose) have proved most successful. Double-cut red clover and white clover, a biannual, showed lesser success, but may be useful as minor species in seed mixes. All legumes performed better when competition from other plants was absent.

The selection of species for revegetation of waste dumps and related areas at Hat Creek would be largely based on those identified above. Mixes of approximately five species, of which three would be grasses, would be selected and seeded, mostly by harrow-seeding methods. Only in areas too steep for harrow-seeding would hydro-seeding be used. Due to the low precipitation, seeding would be carried out in late Fall (September-November) or early Spring (April-May), the former period being favoured in order that maximum use could be made of moisture accumulating over the Winter months. Legumes may benefit from early Spring seeding to reduce losses by Winter kill.

In addition to these agronomic species, native shrubs and forbs considered essential in the reclamation of wildlife habitats would need to be transplanted and/or propagated in the project nursery.

#### 11.5.2 Waste Dumps and Embankments

Rapid revegetation of embankments and waste dumps will stabilize exposed surfaces against erosion. Temporary reclamation will be carried out on all areas of dump surfaces left inactive for a number of years. Retaining embankments will be constructed in lifts which allow for long-term reclamation concurrently with construction. Waste dump surfaces will be reclaimed as soon as the final surface elevation is reached.

Waste dumps will be concurrently revegetated to an end use comparable with adjacent lands at similar elevation. Topography and diversity of native species similar to pre-mining conditions cannot be duplicated, but reclamation of waste dumps will be designed to provide a revegetated, self-sustaining, stable surface composed of materials similar to, or better, than those of adjacent lands. Presently, land in the area is used for mixed wildlife and agricultural (mostly ranching) purposes. It is proposed to revegetate waste dump surfaces to a similar land use as now exists.

As a result of on-site testing as described in 11.5.1, it is proposed to strip and to stockpile surface soils only from those areas where the depth of the soil allows for economic extraction methods. Allowance has been made to cover waste dumps comprised of seam or non-seam material with approximately 1 m of surficial material, though the precise depth required would be established through further on-site testing. Those areas exposed by stripping, and stockpiles of surficial material, would be temporarily revegetated to prevent erosion and dusting.

#### 11.5.3 Material Storage Areas After Abandonment

The coal stockpile and blending area will be levelled and sloped to harmonize with the surrounding topography. The contoured surfaces will then be covered with a buffering medium of non-sodic overburden, and seeded.

The surficial soil stockpiles will decrease progressively as the soil is spread over disturbed lands throughout the mine site. The remains will be levelled, sloped to blend in with the surrounding topography, and seeded.

#### 11.5.4 Transportation Corridors

These take up about 4% of the disturbed land within the mine area. Before construction, suitable surface soils will be removed and stockpiled. Inactive sections will be seeded as soon as possible after construction, to minimize dusting and erosion. Cut and fill slopes will be graded to 26° and seeded. Trees and brush will be removed from rights-of-way to reduce any fire hazard.



During the years immediately following shutdown of the mine, conveyors, transmission lines, and culverts will be dismantled and removed. Wherever possible, corridors will be re-sloped to blend in with the surrounding topography. All roads (except main access roads) will be ripped to relieve compaction, and seeded. Water bars will be constructed on slopes with a potential for rill erosion.

#### 11.5.5 Support Facilities

The present site has a poor quality rating in terms of land use, and the reclamation measures will be designed to enhance the value of the disturbed land.

During construction, the buildings will be screened from the main access roads by a belt of trees, not merely to improve the appearance, but to prevent dusting. No significant reclamation will take place until after the mine closes.

During the years following closure, buildings not retained for alternative uses will be dismantled, sold, and levelled to their foundations. Any areas littered will be cleared during the mine clean-up operation. Most of the Mine Services Area will then be ripped to relieve compaction, covered with 15 to 30 cm of soil, and seeded. Where practical, slopes will be regraded to blend in with the surrounding topography. Where surface materials are unsuitable for plant growth, a suitable depth of overburden will be placed before soil coverage and seeding.

#### 11.5.6 The Open Pit After Abandonment

Considerable planning has gone into measures designed to minimize the potential hazard to human life, livestock, and wildlife, of a large void constructed of weak material. A proposal to flood the pit and convert it into a lake was explored but rejected on the grounds of poor stability of the surrounding ground, the anticipated poor quality of the pit water, and the costly and possibly irrevocable nature of a decision that would make it virtually impossible to re-open the pit at some future time in order to extract the substantial coal reserves which will remain.

The plan adopted provides for re-sloping the top three benches (about 115 ha) from 45° to 26° to provide a safer perimeter and lessen the visual impact. No re-sloping will be done below this level. After re-sloping, fertilizer and seed will be aerially broadcast on all pit benches. Germination is expected to take place readily on those portions which consist of non-sodic glacio-fluvial and glacial till overburden, less readily on those composed of saline slide deposits, sodic siltstones, claystones, and coal. In time, revegetated overburden and slide areas may be expected to creep and to slump into the pit.

A protective fence to restrict access will surround the pit perimeter and those areas to the South-West which may be susceptible to failure. Trees will be planted at selected points on the perimeter to screen the pit.

#### 11.5.7 Disturbances and Possible Resource Losses

A maximum of 1,931 ha will, at one time or another, have been disturbed by Year 35. By Year 45, however, all but 571 ha will have been restored. This represents less than 1% of the Hat Creek Watershed. Of this, 80 ha include transportation corridors, lagoons, reservoirs, and remaining facilities for long-term environmental monitoring. The remaining 491 ha represents the lower portions of the pit itself which would remain as is so as not to preclude the further economic extraction of the coal resource. Table 11-1 shows the details of areas disturbed and those reclaimed by Years 35 and 45. The areas to be reclaimed by Year 45 are shown in Figure 11-1.

The only resources likely to be buried or otherwise alienated by the mine are aggregate (sand and gravel), and some limestone deposits. The latter are insignificant in comparison with the large reserves of limestone in areas immediately adjacent. And much of the aggregate excavated during construction will be stockpiled for future use.

11.6            OTHER MEASURES

11.6.1        Spontaneous Combustion

Tests were carried out in 1977 to determine the spontaneous combustion of loose and compacted coal piles. These showed that with a temperature rise of 60<sup>o</sup>-70<sup>o</sup>C, fires began in piles of loose, uncompacted coal in between four to eight weeks. Precautionary measures will be required to crush and compact the coal in such stockpiles. The problem can be minimized by the restacking time coal spends in uncompacted piles. Monitoring of coal-pile temperature will be required.

11.6.2        Environmental Services Complex

All aspects of the Reclamation and Environmental Protection Plan will be under the control of staff housed in the Environmental Services Complex, which is equipped with modern laboratory facilities. The plant propagation nursery forms part of the complex.

11.6.3        Monitoring

Geotechnical monitoring of pit slopes, waste dumps, and slide areas will continue during mining to ensure operational safety as well as to develop reliable abandonment procedures. The temperature of carbonaceous material will be monitored to prevent spontaneous combustion. The quality of soil and buffer material will be monitored to ensure adequate depth of uncontaminated growth medium. In addition, the quantity, quality, regeneration potential, nutrient and metal content of vegetation grown on disturbed land will be monitored to determine if the vegetation is self-sustaining and satisfactory for livestock and wildlife consumption.

Surface and groundwater will be monitored to ensure compliance with PCB objectives. Seepage and leachate flows will be monitored in groundwater wells; also the discharge from all treatment

lagoons. Broadly speaking, the primary objective of water monitoring will be to segregate sediment-laden water, clear water, waste water, and other surface flow, treat those parts which may require it, and discharge the rest.

Air quality would be monitored for suspended particulate and dustfall levels.

Monitoring will continue for at least 10 years after the mine closes.

#### 11.6.4 Archaeology

A conservation strategy will be adopted to preserve significant heritage resources discovered during the process of excavation. As scraper work will be carried on progressively during mining, there will be sufficient time to complete an inventory of such heritage resources as may be uncovered.

11.7

COSTS

The estimated capital and operating costs of the plan amount to \$40 million. This includes the capital cost of all buildings, field equipment, seed and plant stock. Operating costs include staff and all materials required to carry out the plan.

The reclamation costs span a 6-year pre-production period, 35 years of production, and a 10-year post-production period devoted to reclamation, which will cost approximately \$7 million.

The Environmental Protection Section of this report is based upon Volume V of CMJV's July 1978 report entitled "Mine Reclamation and Environmental Protection". It has not been adjusted to reflect changes in the 1979 Mining Plan, which are considered to be insignificant.

TABLE 11-1

ESTIMATE OF AREAS DISTURBED AND RECLAIMED  
BY YEAR 35 AND YEAR 45

<u>Location</u>	<u>Disturbed by Year 35</u>	<u>Reclaimed</u>	
		<u>by Year 35</u>	<u>by Year 45</u>
<u>Open Pit</u>			
Upper 3 Berms	115	0.0	115
Balance	491		
Sub-total	<u>606</u>		<u>115</u>
<u>Waste Dumps</u>			
Houth Meadows	610	380.0	610
Medicine Creek	385	212.0	385
Sub-total	<u>995</u>	<u>592.0</u>	<u>995</u>
<u>Stockpiles</u>			
Low-Grade Coal	17.2	17.2	17.2
Coal	26.4	0.0	26.4
Topsoil	13.6	13.6	13.6
Sub-total	<u>57.2</u>	<u>30.8</u>	<u>57.2</u>
<u>Service Yards</u>	107	6.0	106.8
<u>Roads</u>			
Pit Perimeter	47.3	15.0	15.0
Main Access	3.0	1.0	1.0
Sub-total	<u>50.3</u>	<u>16.0</u>	<u>16.0</u>
<u>Conveyor Corridors</u>			
Thermal Plant	14.0	7.0	14.0
Medicine Creek	6.0	3.0	6.0
Sub-total	<u>20.0</u>	<u>10.0</u>	<u>20.0</u>
<u>Water Treatment Lagoons</u>			
Main	9.0	2.0	2.0
Medicine Creek	2.0	0.5	0.5
Sub-total	<u>11.0</u>	<u>2.5</u>	<u>2.5</u>
<u>Clearwater Reservoirs</u>			
Headworks (upper)	6.1	2.0	2.0
Pit Rim (lower)	8.8	4.0	4.0
Sub-total	<u>14.9</u>	<u>6.0</u>	<u>6.0</u>
<u>Ditches</u>	27.0	6.5	6.5
<u>Stream Diversions</u>			
Hat Creek	33.6	27.0	27.0
Finney Creek	8.9	8.0	8.0
Sub-total	<u>42.5</u>	<u>35.0</u>	<u>35.0</u>
GRAND TOTAL	<u>1,931.0</u>	<u>704.8</u>	<u>1,360.0</u>

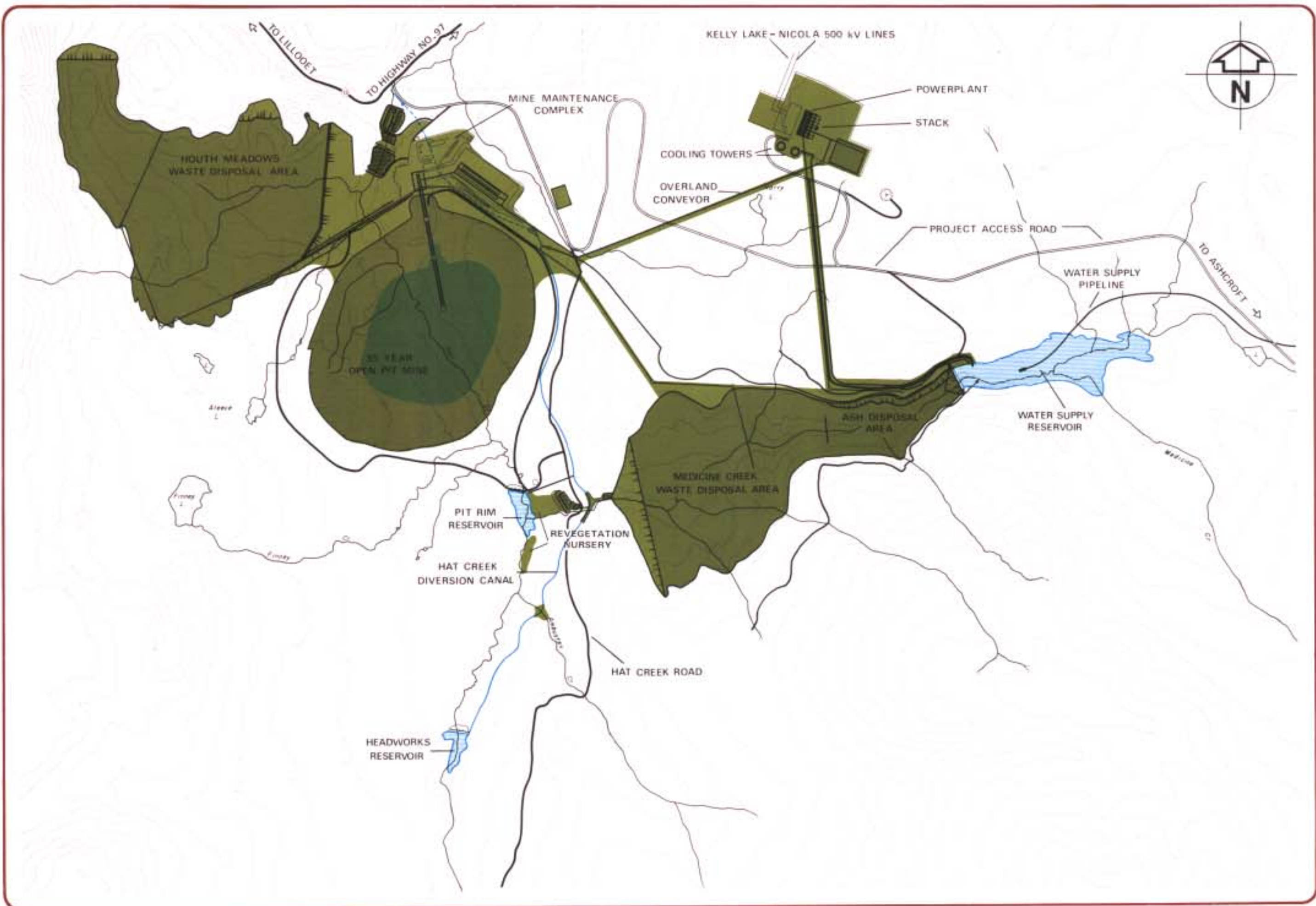

**LEGEND**

- RECLAIMED AREA (MAJOR RECLAMATION)
- RECLAIMED AREA (MINOR RECLAMATION)

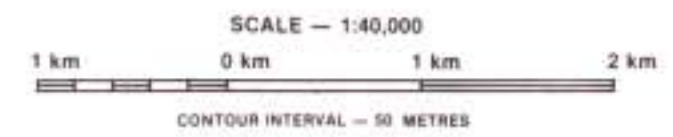

HAT CREEK PROJECT  
**FIGURE 4.3**  
**RECLAMATION — YEAR 45**

SOURCE: Cominco — Minera Joint Venture (J)





<u>No.</u>	<u>LIST OF TABLES</u>	<u>Page</u>
13-1	Schedule of Peak Manpower Requirements	1
13-2	Manpower Schedule - Summary	5

LIST OF FIGURES

13-1	Organization Chart	6
------	--------------------	---

TABLE 13-1

Sheet 1 of 4

## SCHEDULE OF PEAK MANPOWER REQUIREMENTS

	Pre- prod.	1	2	3	4	5	6- 15	16- 25	26- 35
<u>1. Management</u>									
Managers	2	2	2	2	2	2	2	2	2
Industrial Engineering	4	4	4	4	4	4	4	4	4
Public Relations	2	2	2	2	2	2	2	2	2
Computer Services	4	4	4	4	4	4	4	4	4
Laboratory Services	5	5	5	5	5	5	5	5	5
Environment Protection and Reclamation	7	7	7	7	7	7	7	9	9
Secretaries, Clerical, Stenos.	<u>8</u>	<u>8</u>	<u>8</u>	<u>8</u>	<u>8</u>	<u>8</u>	<u>8</u>	<u>8</u>	<u>8</u>
	<u>32</u>	<u>32</u>	<u>32</u>	<u>32</u>	<u>32</u>	<u>32</u>	<u>32</u>	<u>34</u>	<u>34</u>
<u>2. Administration - Supt.</u>									
Finance - Cost Accounting and Payroll	4	4	4	4	4	4	4	4	4
Materials Management - Purchasing, Warehouse	10	10	10	10	10	10	10	10	10
Security Services	5	5	5	5	5	5	5	5	5
Fire Department	3	3	3	3	3	3	3	3	3
Janitorial Services and Office Bldgs. Maintenance	10	10	10	10	10	10	10	10	10
Dry Facilities	4	4	4	4	4	4	4	4	4
Communications - Radio, Telephone, Telex	12	12	12	12	12	12	12	12	12
Water, Fuel, Sewerage; Wastewaters, Garbage Disposal	5	5	5	5	5	5	5	5	5
Transportation - Bus Service and Delivery Drivers	5	18	21	21	21	21	21	21	21
Surface Labour - Road Maintenance, Plant Yard Scrap	6	6	6	6	6	6	6	6	6
Secretaries, Clerical, Stenos.	<u>29</u>	<u>29</u>	<u>29</u>	<u>29</u>	<u>29</u>	<u>29</u>	<u>29</u>	<u>29</u>	<u>29</u>
	<u>90</u>	<u>103</u>	<u>106</u>	<u>106</u>	<u>106</u>	<u>106</u>	<u>106</u>	<u>106</u>	<u>106</u>

	Pre- prod.	1	2	3	4	5	6- 15	16- 25	26- 35
<b>3. Human Resources -</b>									
Supt.	1	1	1	1	1	1	1	1	1
Labour Relations Dept.	2	2	2	2	2	2	2	2	2
Training School	8	8	8	8	8	8	8	8	8
Personnel Department	3	3	3	3	3	3	3	3	3
Safety and First Aid Secretaries, Steno.	5	7	7	7	7	7	7	7	7
	<u>6</u>	<u>6</u>	<u>6</u>	<u>6</u>	<u>6</u>	<u>6</u>	<u>6</u>	<u>6</u>	<u>6</u>
	<u>25</u>	<u>27</u>	<u>27</u>	<u>27</u>	<u>27</u>	<u>27</u>	<u>27</u>	<u>27</u>	<u>27</u>
<b>4. Mine Engineering -</b>									
Supt.	1	1	1	1	1	1	1	1	1
Pit Engineer	1	1	1	1	1	1	1	1	1
Planning Engineers	4	4	4	4	4	4	4	4	4
Draftsmen	2	2	2	2	2	2	2	2	2
Samplers and Grade Officer	3	3	4	5	5	5	5	5	5
Surveyors	4	4	4	4	4	4	4	4	4
Geologists	4	5	6	6	6	6	6	6	6
Geotechnical Engineers and Technician	2	2	2	2	2	2	2	2	2
Helpers (Survey, Rodmen)	4	4	4	4	4	4	4	4	4
Secretary, Clerical, Stenos.	2	2	2	4	4	4	4	4	4
	<u>27</u>	<u>28</u>	<u>30</u>	<u>33</u>	<u>33</u>	<u>33</u>	<u>33</u>	<u>33</u>	<u>33</u>
<b>5. Mine Supervision (Operations)</b>									
Supt. and Assistant	2	2	2	2	2	2	2	2	2
Shift Supervisors	2	2	4	4	4	4	4	4	4
Production - Shift Foremen	3	4	4	4	4	4	4	4	4
Production - Dump Pocket Foremen, Crusher	4	4	4	4	4	4	4	4	4
Processing - Coal Plant Foremen	2	2	3	4	4	4	4	4	4
Processing - Waste Dump Foremen	4	4	4	4	4	4	4	4	4
Pit Maintenance - Roads Foremen	4	4	4	4	4	4	4	4	4
Pit Maintenance - Drainage Foremen	4	4	4	4	4	4	4	4	4
Clerical and Steno.	3	3	4	5	5	5	5	5	5
	<u>28</u>	<u>29</u>	<u>33</u>	<u>35</u>	<u>35</u>	<u>35</u>	<u>35</u>	<u>35</u>	<u>35</u>

	Pre- prod.	1	2	3	4	5	6- 15	16- 25	26- 35
<u>6. Maintenance Engineering</u> (Supervision)									
Supt. and Assistant Engineering Design -	2	2	2	2	2	2	2	2	2
Engineers, Draftsmen	3	3	3	3	3	3	3	3	3
Maintenance Planning	2	2	3	5	5	5	5	5	5
Operations Maintenance - Mechanical	3	5	6	8	9	9	9	9	9
Operations Maintenance - Electrical	4	5	6	6	6	6	6	6	6
Pit Equipment Maintenance - Mechanical Supervisor	2	3	4	5	5	5	5	5	5
Surface Yard and Carpenter Foremen	2	2	2	2	2	2	2	2	2
Clerical and Steno.	3	4	4	4	4	4	4	4	4
	<u>21</u>	<u>26</u>	<u>30</u>	<u>35</u>	<u>36</u>	<u>36</u>	<u>36</u>	<u>36</u>	<u>36</u>
<u>7. Mine Operations</u>									
Shovel - Operators	4	6	10	15	21	23	24	20	15
Shovel - Oilers	2	3	5	6	9	10	11	8	6
Haulage Truck Drivers	9	14	24	36	52	60	62	59	42
Conveying Coal	10	10	21	26	29	29	30	30	30
Conveying Waste		23	24	28	28	28	36	36	36
Drilling and Blasting Heavy Equipment Operators	2	3	3	3	3	3	4	3	3
Service Truck Drivers	50	57	68	68	73	81	81	54	42
Mobile Crusher	8	9	11	12	16	18	18	18	15
Pit Dewatering and Drainage	2	2	2	2	2	2	2	2	2
	5	6	6	6	7	7	7	7	7
Total Mine Operations	<u>92</u>	<u>139</u>	<u>174</u>	<u>192</u>	<u>240</u>	<u>261</u>	<u>275</u>	<u>237</u>	<u>198</u>

Pre- Prod.	1	2	3	4	5	6- 15	16- 25	26- 35
---------------	---	---	---	---	---	----------	-----------	-----------

8. Maintenance Labour

Central Shops and  
Services:

H.D. Mechanic	24	30	36	44	49	54	54	44	34
Auto Mechanic	6	8	8	12	18	19	19	16	12
Tiremen	6	8	8	8	8	10	10	8	6
Welder	7	7	10	10	14	16	18	14	8
Machinist	4	4	6	6	6	8	10	8	6
Carpenter	3	3	4	6	6	8	8	8	6
Pipefitter	3	3	3	3	3	3	3	3	3
Painter	2	2	2	2	2	2	2	2	2
Radio Technician	2	3	3	3	3	3	3	3	3
Electrician	12	14	18	23	23	23	23	23	23
Crane Operator	3	3	3	3	3	3	3	3	3
Labourer	10	10	12	12	14	16	16	14	12

Field Services:

H.D. Mechanic	8	8	18	22	28	28	28	22	15
Conveyor Mechanic	3	12	17	27	34	34	40	45	38
Belt Vulcanizer	2	4	4	4	4	4	4	4	4
Lube Servicemen	<u>5</u>	<u>6</u>	<u>9</u>	<u>9</u>	<u>10</u>	<u>10</u>	<u>10</u>	<u>10</u>	<u>10</u>
Total Labour	<u>100</u>	<u>125</u>	<u>161</u>	<u>194</u>	<u>225</u>	<u>241</u>	<u>251</u>	<u>229</u>	<u>185</u>

TABLE 13-2

MANPOWER SCHEDULE - SUMMARY

	Pre- prod.	1	2	3	4	5	6- 15	16- 25	26- 35
Management and Reclamation P.C.	32	32	32	32	32	32	32	34	34
Administration and Site Services	90	103	106	106	106	106	106	106	106
Human Resources	25	27	27	27	27	27	27	27	27
Mine Supervision - Engineering	27	28	30	33	33	33	33	33	33
Mine Supervision - Operations	28	29	33	35	35	35	35	35	35
Maintenance Supervision	21	26	30	35	36	36	36	36	36
Mine Operations - Labour	92	139	174	192	240	261	275	237	198
Maintenance - Labour	100	125	161	194	225	241	251	229	185
Subtotals	415	509	593	654	734	771	795	737	654
Contingency - 10%	42	51	59	65	73	77	79	74	65
Totals	457	560	652	719	807	848	874	811	719

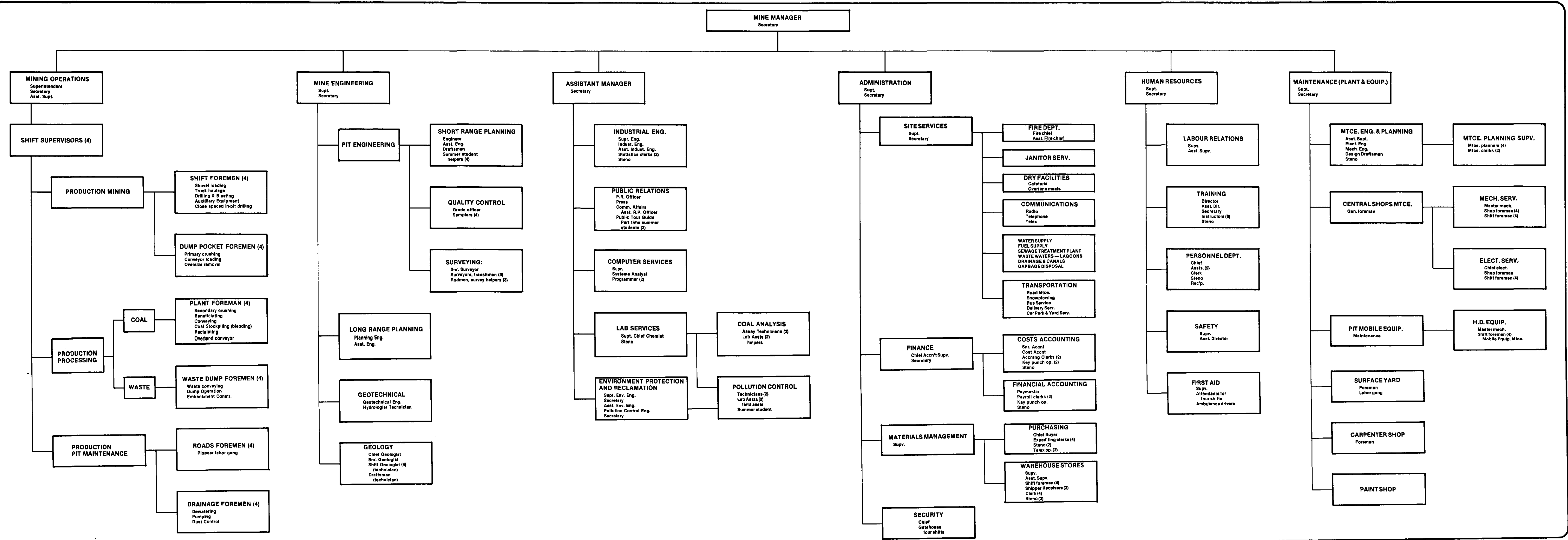

HAT CREEK PROJECT  
 FIGURE 13-1  
 Organization Chart

SOURCE: British Columbia Hydro and Power Authority

14	<u>ECONOMICS AND COSTS ESTIMATES</u>	<u>Page</u>
14.1	Summary	1
14.2	Estimating Criteria	4
14.2.1	Introduction	4
14.2.2	Overall Approach to the Development of the Project Cash Flow	4
14.2.2.1	Equipment Productivity Standards	8
14.2.2.2	Equipment Cost Standards	8
14.2.3	Capital Cost Estimating Criteria	9
14.2.3.1	Buildings and Civil Works	9
14.2.3.2	Major Equipment	9
14.2.4	Operating Cost Estimating Criteria	13
14.2.4.1	Staff Salaries and Benefits	13
14.2.4.2	Hourly Labour Rates	13
14.2.4.3	Mine Operating Schedules	14
14.2.4.4	Materials Parameters	14
14.2.4.5	Equipment Parameters	15
	14.2.4.5.1 Drilling and Blasting Equipment	15
	14.2.4.5.2 Loading Equipment	15
	14.2.4.5.3 Haulage Trucks	15
	14.2.4.5.4 Coal and Waste-handling Systems	16
14.3	Capital Costs	34
14.3.1	Description of Costs Included in the Major Cost Centres	35
14.3.1.1	Engineering and Construction	35
14.3.1.2	Mine Property Development	35
14.3.1.3	Buildings and Structures	35
14.3.1.4	Mining Equipment	36
14.3.1.5	Coal Conveying, Crushing, and Blending Equipment	36
14.3.1.6	Low-grade Coal Beneficiation Equipment	37
14.3.1.7	Waste Disposal Equipment	37
14.3.1.8	Reclamation and Environmental Protection	38
14.3.1.9	Contingency	38



	<u>Page</u>
14.4 Operating Costs	41
14.4.1 Description of Costs Included in the Major Cost Centres	42
14.4.1.1 Drilling and Blasting	42
14.4.1.2 Loading and Hauling	42
14.4.1.3 Coal and Waste-handling Systems	42
14.4.1.4 Auxiliary Equipment	43
14.4.1.5 Power	43
14.4.1.6 General Mine Expense	43
14.4.1.7 Overhead	46
14.4.1.8 Royalties	48
14.4.1.9 Contingency	48
14.4.1.10 Contractor's Allowance	48
14.5 Financial Analysis	60
14.5.1 Approach	60
14.5.2 Parameters	60
14.5.3 Analysis	61
14.5.4 Conclusion	62

<u>No.</u>	<u>LIST OF TABLES</u>	<u>Page</u>
14-1	Summary of Annual Costs	2
14-2	Breakdown of Total Estimated Capital and Operating Expenditures by Major Cost Centres	3
14-3	Equipment Capital Costs and Service Lives	10
14-4	Annual Salaries of Mine Staff	18
14-5	Labour Rates for Mine Operations Staff	19
14-6	Productivity Standards for Functional Cost Centres	20
14-7	Standard Costs for Functional Cost Centres	28
14-8	Development of Capital Costs for Major Mine Equipment	39
14-9	Summary of Capital Costs by Major Cost Centres	40
14-10	Development of Operating Costs for Functional Cost Centres	49
14-11	Summary of Operating Costs by Major Cost Centres	59
14-12	Other Costs Allocated to Mining Project	63

LIST OF FIGURES

14-1	Overall Approach to Development of Cash Flow	5
14-2	Development of Equipment Productivity Standards	6
14-3	Development of Standard Costs Per Shift for Machine Operations	7

## SECTION 14

### ECONOMICS AND COSTS ESTIMATES

#### 14.1 SUMMARY

Having selected the shovel/truck/conveyor mining system, a production schedule was developed which satisfied the annual fuel requirements of the proposed generating station over the 35-year project life. The capital and operating costs associated with all mining operations necessary to deliver coal to the powerplant in accordance with this schedule are presented in this section.

The following criteria were used in preparing the cost estimates:

- (1) The cost estimates are presented in 1979 Canadian dollars;
- (2) Operating costs incurred in the pre-production years have not been transferred to capital costs;
- (3) The following costs were excluded from the estimates: B.C. Hydro corporate overhead, land purchase or lease costs, mineral rights purchase or lease costs, and the costs of housing mine personnel.

On the basis of the recommended mining system, the total estimated capital costs of this project are \$538,261,000, and the total estimated operating costs are \$1,836,060,000. The estimated capital requirements to full production, i.e. to the end of the third production year, are \$248,463,000. Table 14-1 provides an overall project cost summary, including the annual operating and capital costs, the cumulative cash flow, and the annual unit costs. The total estimated capital and operating expenditures over the life of the project are summarized according to major cost centres in Table 14-2.

TABLE 14-1

SUMMARY OF ANNUAL COSTS, CANADIAN \$ OCTOBER 1979  
HAT CREEK PROJECT MINING REPORT 1979

Year	Annual Coal Production		\$000's Annual Operating Cost	\$ Annual Operating Cost/tonne	\$ Annual Operating Cost/GJ	\$000's Annual Capital Costs	\$000's Total Annual Capital + Operating Cost	\$000's Total Cumulative Operating + Capital Cost
	x 10 <sup>6</sup> tonnes	MJ x 10 <sup>9</sup>						
-6						69	69	69
-5			72			6,144	6,216	6,285
-4			2,367			25,864	28,231	34,516
-3			5,531			40,985	46,516	81,032
-2			18,638			76,219	94,857	175,889
-1	1.14	15.35	28,548	25.04	1.86	38,395	66,943	242,832
1	2.95	43.56	34,091	11.56	0.78	19,205	53,296	296,128
2	4.76	66.27	39,523	8.30	0.60	34,504	74,027	370,155
3	7.35	101.77	46,480	6.32	0.46	7,078	53,558	423,713
4	9.23	130.63	53,434	5.79	0.41	11,242	64,676	488,389
5	10.46	146.43	57,221	5.47	0.39	22,176	79,397	567,786
6	10.60	150.02	57,615	5.44	0.38	9,563	67,178	634,964
7	10.52	149.69	57,091	5.43	0.38	16,643	73,734	708,698
8	11.49	150.31	57,438	5.00	0.38	17,126	74,564	783,262
9	10.69	149.65	57,226	5.35	0.38	10,168	67,394	850,656
10	11.37	150.48	59,441	5.23	0.39	9,152	68,593	919,249
11	11.17	150.39	56,669	5.07	0.38	17,878	74,547	993,796
12	10.86	150.37	59,898	5.52	0.40	9,747	69,645	1,063,441
13	11.64	149.60	60,782	5.22	0.41	12,970	73,752	1,137,193
14	11.40	150.00	60,356	5.29	0.40	15,260	75,616	1,212,809
15	11.12	149.72	56,165	5.05	0.38	2,846	59,011	1,271,820
16	10.06	138.53	54,271	5.39	0.39	4,852	59,123	1,330,943
17	10.06	139.30	53,624	5.33	0.38	10,085	63,709	1,394,652
18	10.67	139.58	52,352	4.91	0.38	4,919	57,271	1,451,923
19	10.15	138.99	50,808	5.01	0.37	18,582	69,390	1,521,313
20	9.90	139.35	50,420	5.09	0.36	14,869	65,289	1,586,602
21	9.66	139.67	48,503	5.02	0.35	4,396	52,899	1,639,501
22	9.57	139.10	48,964	5.12	0.35	4,212	53,176	1,692,677
23	10.40	139.23	48,972	4.71	0.35	12,966	61,938	1,754,615
24	10.03	139.65	48,707	4.86	0.35	3,905	52,612	1,807,227
25	9.83	139.12	48,569	4.94	0.35	3,150	51,719	1,858,946
26	8.01	117.65	46,557	5.81	0.40	10,817	57,374	1,916,320
27	9.19	118.11	46,552	5.07	0.39	2,214	48,766	1,965,086
28	8.39	118.10	46,548	5.55	0.39	6,016	52,564	2,017,650
29	8.55	117.73	46,696	5.46	0.40	13,131	59,827	2,077,477
30	8.58	117.49	46,211	5.39	0.39	3,175	49,386	2,126,863
31	8.64	117.65	45,913	5.31	0.39	3,251	49,164	2,176,027
32	8.61	117.90	45,874	5.33	0.39	9,475	55,349	2,231,376
33	8.25	118.02	45,706	5.54	0.39	1,866	47,572	2,278,948
34	8.05	117.62	39,984	4.97	0.34	2,378	42,362	2,321,310
35	7.62	117.75	39,426	5.17	0.33	508	39,934	2,361,244
36			2,416			94	2,510	2,363,754
37			2,416			17	2,433	2,366,187
38			2,416			22	2,438	2,368,625
39			2,095			35	2,130	2,370,755
40			2,095			45	2,140	2,372,895
41			483			10	493	2,373,388
42			483			23	506	2,373,894
43			289			14	303	2,274,197
44			62				62	2,374,259
45			62				62	2,374,321
Total	330.95	4,574.78	1,836,060	5.55	0.40	538,261	2,374,321	2,374,321

TABLE 14-2

BREAKDOWN OF TOTAL ESTIMATED CAPITAL AND  
OPERATING EXPENDITURES BY MAJOR COST CENTRES

(\$000's October 1979)

Hat Creek Project Mining Report 1979

Cost Centre	Amount (\$000's)	(\$ Unit Cost/tonne of Coal Delivered	(\$ Unit Cost/GJ
Engineering and Construction Costs	29,168	0.09	
Mine Property Development	44,566	0.13	
Buildings and Structures	18,077	0.05	
Mining Equipmen	257,757	0.78	
Coal Conveying, Crushing, and Blending Equipment	51,341	0.16	
Low-grade Coal Beneficiation Equipment	9,549	0.03	
Waste Disposal Equipment	73,101	0.22	
Reclamation and Environmental Protection	1,535	0.01	
Contingency	<u>53,167</u>	<u>0.16</u>	
<b>TOTAL CAPITAL COSTS</b>	<b>538,261</b>	<b>1.63</b>	<b>0.12</b>
Drilling	2,008	0.01	
Blasting	5,764	0.02	
Loading	97,739	0.30	
Hauling	262,072	0.79	
Coal-handling System	70,835	0.21	
Waste-handling System	85,585	0.26	
Auxiliary Equipment	111,740	0.34	
Power	140,293	0.42	
General Mine Expense (less Reclamation and Environmental Protection)	385,068	1.16	
Reclamation and Environmental Protection	38,638	0.12	
Overhead	251,416	0.76	
Royalties	115,837	0.35	
Contingency	145,110	0.44	
Contractor's Allowance	<u>123,955</u>	<u>0.37</u>	
<b>TOTAL OPERATING COSTS</b>	<b>1,836,060</b>	<b>5.55</b>	<b>0.40</b>

14.2            ESTIMATING CRITERIA

14.2.1        Introduction

This section of the report discusses the approach used in developing the cash flow of capital and operating costs for the recommended mining scheme.

The capital cost estimating criteria, primarily concerning the cost and service life of the major equipment, are provided in Section 14.2.3.

The estimating criteria used in developing the operating costs are presented in Section 14.2.4 and consist mainly of labour rates and major equipment productivity and cost standards.

14.2.2        Overall Approach to the Development of the Project Cash Flow

The system used to develop annual capital and operating costs is shown in Figures 14-1, 14-2, and 14-3.

Having determined a practical and economic production schedule for the recommended shovel/truck/conveyor mining system, the next phase of the study was to carry out an analysis to determine the size and type of shovels and trucks to be employed in the mining operation. This analysis is discussed in Section 9. Basically, owning and operating costs were developed for various combinations of shovel/truck systems at critical periods during the life of the project. An analysis of this information then resulted in the selection of the shovels and trucks for the mining system. Capital and operating costs for the major mining equipment were then produced for the project life.

All additional costs to support the mining system were then developed. These include the costs for all auxiliary equipment, support facilities, material-handling systems, reclamation and environmental protection, overhead and general mine expenses.

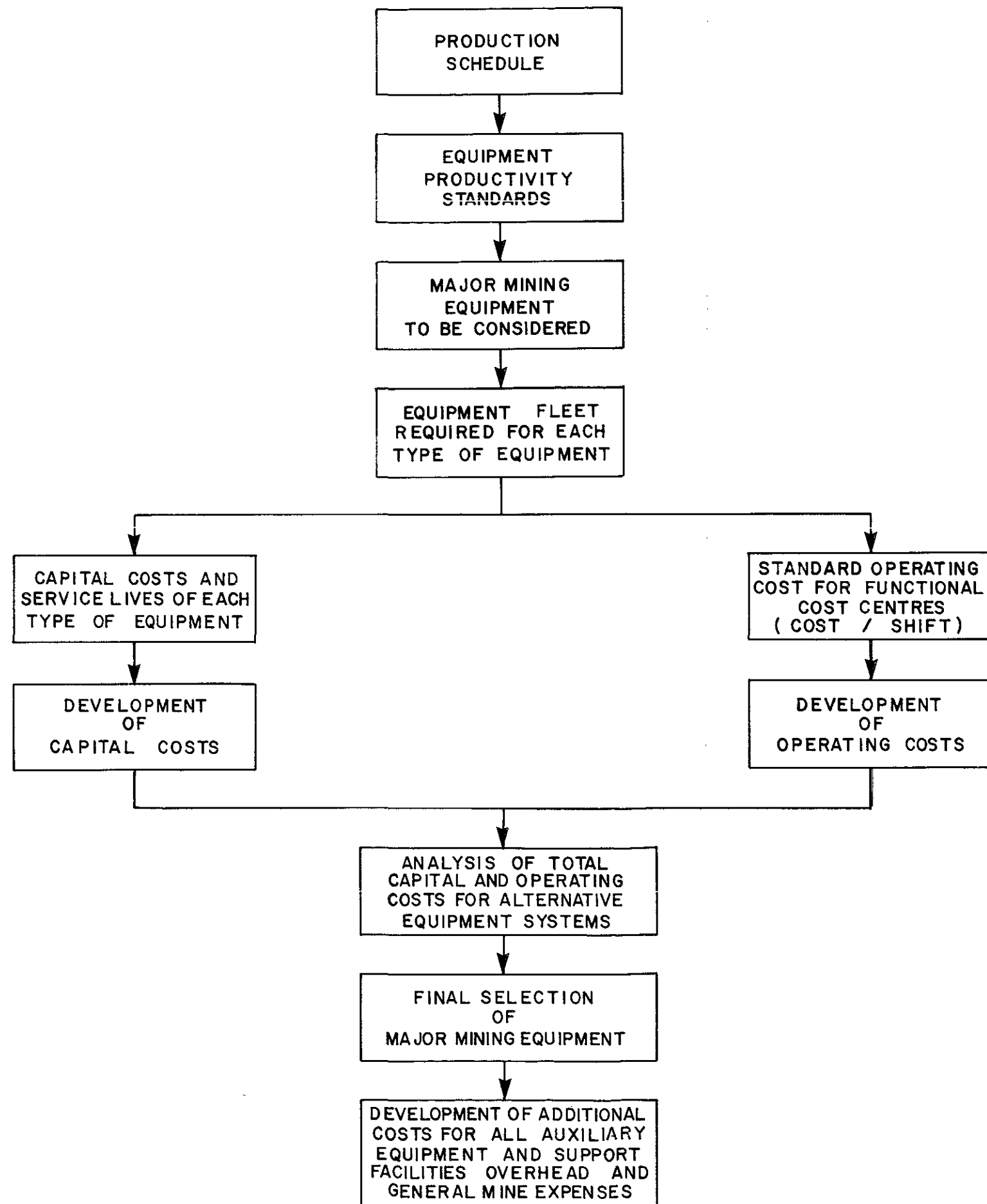

HAT CREEK PROJECT

FIGURE 14-1

**Overall Approach to  
Development of Cash Flow**

SOURCE: British Columbia Hydro and Power Authority

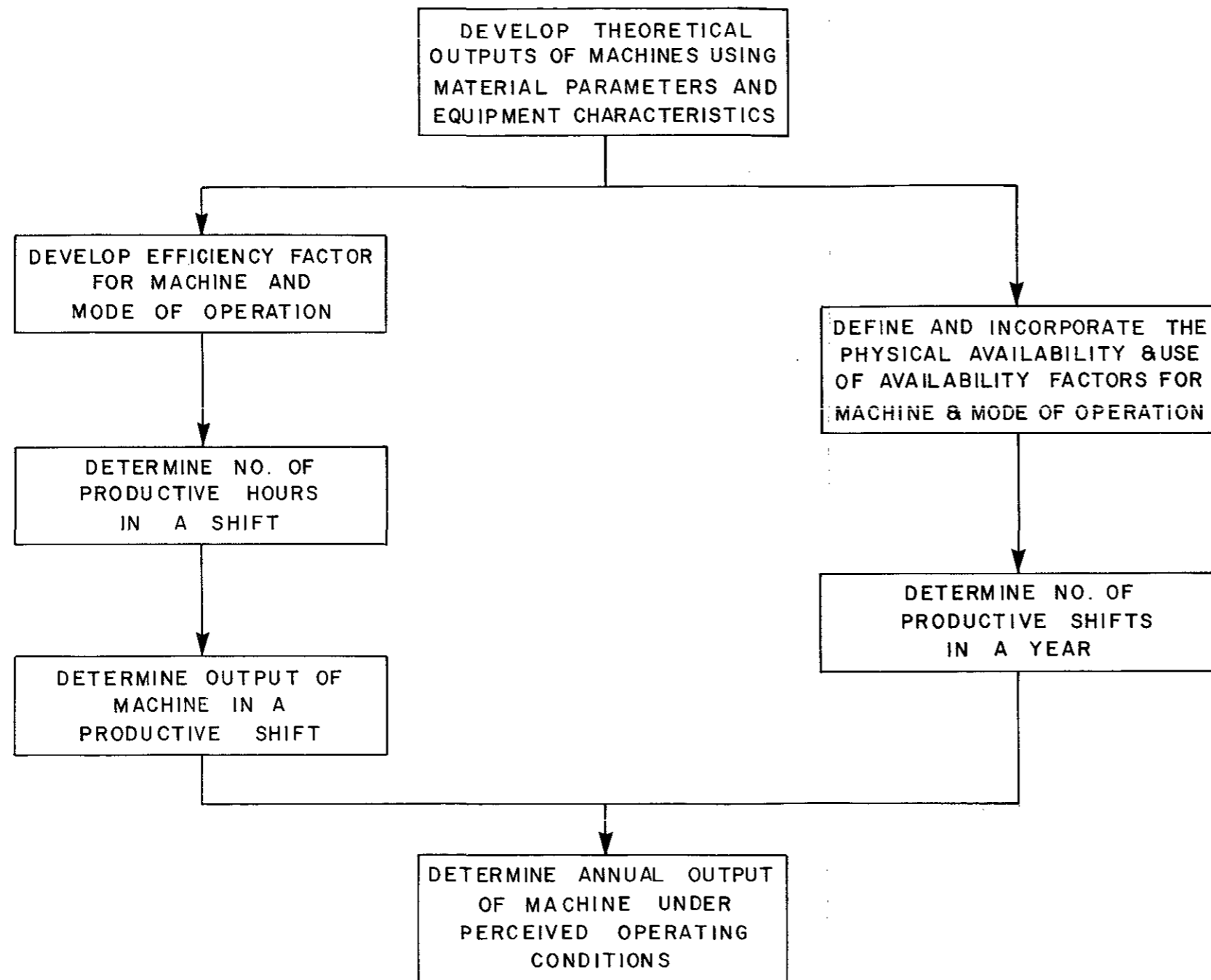

HAT CREEK PROJECT

**FIGURE 14-2  
Development of Equipment  
Productivity Standards**

SOURCE: British Columbia Hydro and Power Authority



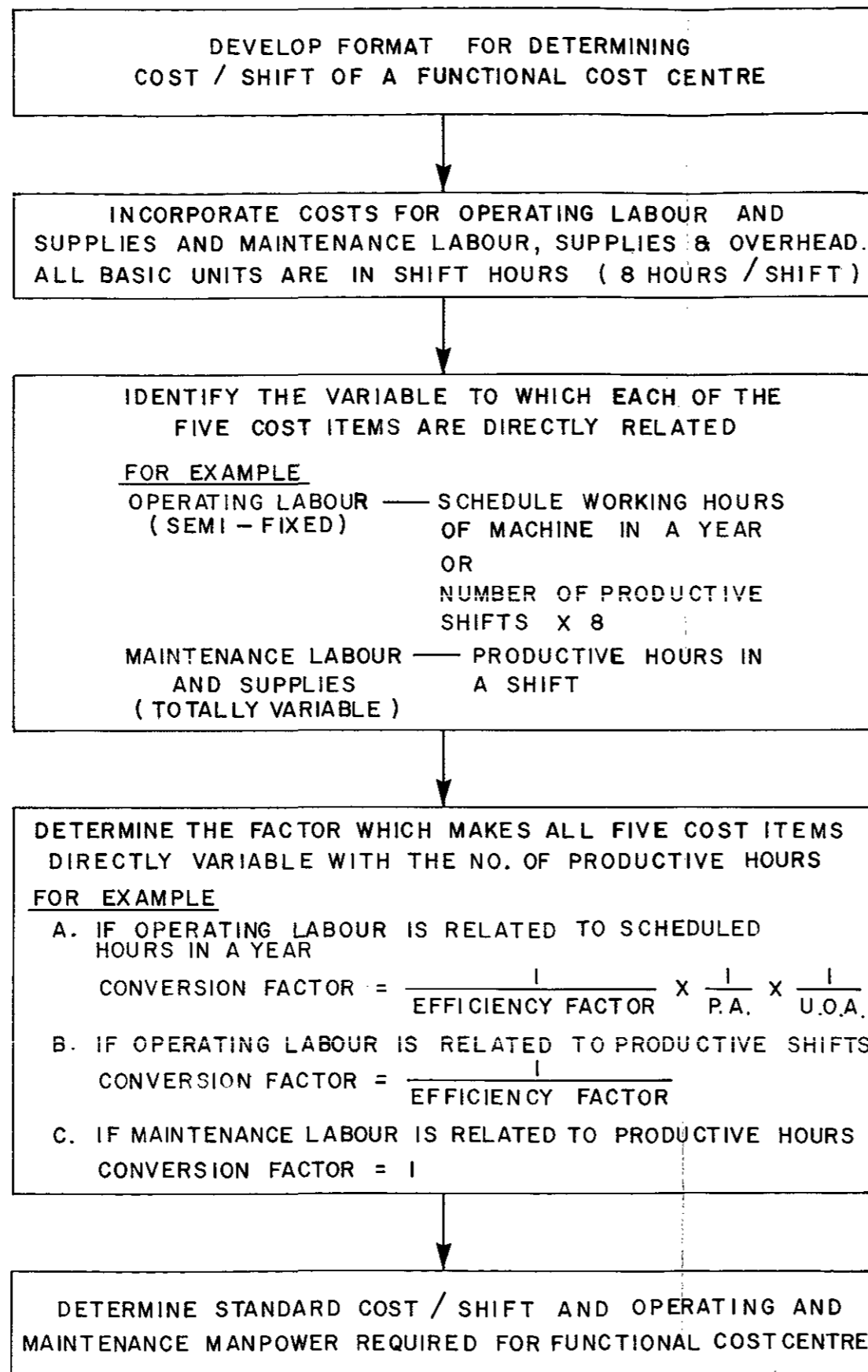

HAT CREEK PROJECT

**FIGURE 14-3**

**Development of Standard Costs per Shift for Machine Operations**

SOURCE: British Columbia Hydro and Power Authority

Equipment requirements and costs for the project were developed with the aid of equipment productivity and cost standards.

#### 14.2.2.1 Equipment Productivity Standards

Theoretical hourly outputs of machines were produced using the material parameters and machine characteristics. The number of productive hours in a shift were then determined for the mode of operation envisaged. From these factors the actual output of a machine in a shift was calculated. The experience of operating mines was used to develop the physical availability of machines working under a particular regime, as well as the use of such availability. These parameters enabled the number of productive shifts in a year to be calculated. Knowing the machines' output in a shift and the number of productive shifts in a year, the annual productivity of the machine under certain expected operating conditions was determined.

#### 14.2.2.2 Equipment Cost Standards

The cost standards for different pieces of equipment were developed from the following five cost items: operating labour, operating supplies, maintenance labour, maintenance parts and supplies, and maintenance overhead. These cost standards were developed on a shift basis similar to those of the productivity standards.

Depending on the mode of operation, equipment, fleet size, labour agreements, etc., the cost item can be established as fixed, variable, or semi-fixed. For each cost item the price per basic unit was identified (e.g. labour rate for a shovel operator, power cost per hour of shovel operation), and the variable to which this basic unit was related (e.g. scheduled working hours, productive hours). From these data the standard cost per shift for each major piece of equipment was established. The cost data used in these calculations were based on the experience of operating mines in the Province. From the systematic development of a cost standard for each piece of equipment in a functional cost centre, it was then possible to build up the operating and maintenance manpower requirements.

14.2.3            Capital Cost Estimating Criteria

14.2.3.1        Buildings and Civil Works

The costs of civil works were developed taking into account prevailing labour agreements and productivity in the B.C. construction industry. Unit costs of major building components were reviewed with trade contractors.

14.2.3.2        Major Equipment

The capital costs for the major mobile mining equipment and the coal conveying, crushing, and blending equipment were developed based on manufacturers' listed prices and quotations in October 1979 dollars. The capital unit cost for each item of equipment includes:

- purchase cost of equipment FOB factory;
- allowance for optional extras;
- freight and insurance to site;
- Provincial sales tax at 4% of FOB site cost;
- erection costs at site.

Where manufacturers' quotations were in U.S. dollars, an exchange rate of \$1.15 Canadian to \$1.00 U.S. was used. A summary of the capital costs and service lives of the major equipment is presented in Table 14-3. These figures are based partly on suppliers' recommendations and partly on actual figures obtained from a survey of similar operations.

## EQUIPMENT CAPITAL COSTS AND SERVICE LIVES

<u>Item</u>	<u>Capital Cost</u> 1979 \$ FOB Hat Creek	<u>Service Life</u> <u>Op. Hours</u>
<u>Drills</u>		
Auger: truck-mounted	198,000	15,000
Air-Trac c/w Compressor	130,000	15,000
<u>Shovels (rope)</u>		
16.8 m <sup>3</sup>	3,360,000	90,000
<u>Shovels (hydraulic)</u>		
Poclain 1000 CK	1,365,000	36,000
Demag H241	2,220,000	45,000
<u>Front-end Loader</u>		
5.4 m <sup>3</sup>	342,000	15,000
9.6 m <sup>3</sup>	671,000	15,000
<u>Haulage Truck</u>		
32 t	295,000	25,000
77 t (coal box)	524,000	33,000
154 t (rock box)	776,000	33,000
<u>Scraper</u>		
Cat 631	360,000	15,000
Cat 637	415,000	15,000
<u>Dozer (track)</u>		
Cat 955	81,000	15,000

...continued...

<u>Item</u>	<u>Capital Cost</u> 1979 \$ FOB Hat Creek	<u>Service Life</u> <u>Op. Hours</u>
Cat D7	175,000	15,000
Cat D8 with ripper	246,000	15,000
Cat D9 with ripper	355,000	15,000
<u>Dozer (wheel)</u>		
Cat 824B	219,000	25,000
<u>Compactor</u>		
Cat 825B	240,000	20,000
Vibratory (towed)	40,000	20,000
<u>Grader</u>		
Cat 14G	195,000	25,000
Cat 16G	261,000	25,000
<u>Crane</u>		
15 t	135,000	20,000
45 t	255,000	20,000
70 t	382,000	35,000
<u>Trucks (miscellaneous)</u>		
5 t service	19,000	20,000
3 t flatdeck (with 2 t crane)	26,000	20,000
Tire truck	38,000	20,000
Line truck	70,000	32,000
Fuel truck	60,000	20,000
Lube truck	91,000	20,000
Water wagon 45.5 kL	300,000	25,000
Pick-up 1 t	11,000	8,000
Pick-up 3/4 t	9,000	8,000
Fire truck	65,000	50,000
Ambulance	18,000	20,000
Personnel bus (24 passengers)	20,000	20,000
Personnel bus (12 passengers)	12,000	20,000
Sanding truck 10 t	35,000	25,000

...continued...

<u>Item</u>	<u>Capital Cost</u> 1979 \$ FOB Hat Creek	<u>Service Life</u> <u>Op. Hours</u>
<u>Pumps</u>		
10 cm diesel	4,000	13,000
15 cm diesel	7,000	13,000
<u>Welders (portable)</u>		
600 A diesel	6,000	13,000
600 A electric	3,000	20,000
<u>Miscellaneous</u>		
Backhoe (1 m <sup>3</sup> )	160,000	30,000
Compressor (17 m <sup>3</sup> /min.)	63,000	25,000
Steam cleaner (mobile)	64,000	20,000
Lighting plant (3 kw)	11,000	10,000
Gradall	134,000	32,000
50 kw generator	21,000	32,000
Lo-boy tractor	86,000	32,000
Hi-boy trailer	43,000	32,000
Crushing plant	322,000	25,000
CaCl spreader box only	8,000	20,000
Lube island	86,000	PIT LIFE
Forklift 3 t (warehouse)	27,000	12,000
Forklift 5 t (shops)	54,000	12,000

14.2.4            Operating Cost Estimating Criteria

14.2.4.1        Staff Salaries and Benefits

Staff salaries were developed based on a salary survey conducted in 1979 for the Mining Association of British Columbia, as well as in-house experience of current salary levels in operating mines. A summary of the salaries used is presented in Table 14-4.

14.2.4.2        Hourly Labour Rates

Hourly wage rates and benefits were developed from a review of current labour agreements in eight B.C. mines and are based on mine operating schedules of 3 shifts/day and 1 shift/day. The rates used in the study are presented in Table 14-5. The payroll burden was estimated at 28% of the basic rate and included the following benefits:

	% of Base Rate
Company Pension Plan	6.0
Vacations	6.0
Statutory Holidays	4.2
Sick Benefits	3.0
Workers' Compensation	2.5
Group Life Insurance	0.7
Income Continuance	0.6
Unemployment Insurance Commission	1.3
Canada Pension Plan	1.0
Medical Services Plan	0.8
Extended Health Plan	0.1
Dental Plan	0.8
Miscellaneous	<u>1.0</u>
Total	28.0%

14.2.4.3 Mine Operating Schedules

The schedule of operating and maintenance shifts at the mine is summarized below:

Operating and maintenance days per year (statutory holidays will not be worked)	354 days/year
Mine production shifts (1 crew on swing shift)	3 shifts/day
Mine maintenance shifts (1 crew on swing shift)	3 shifts/day
Shop maintenance shifts (1 crew on swing shift)	3 shifts/day
General service shifts (5 days/week, 52 weeks/year, no swing shift)	1 shift/day
Operating and maintenance hours/shift	8 hours/shift

14.2.4.4 Materials Parameters

The materials parameters, upon which calculations of productivities for the loading equipment are based, are given below:

Swell Factors	
Coal (fuel)	35%
Unconsolidated waste (above bedrock)	20%
Consolidated waste	30%
Specific Gravity	
Coal (fuel)	1.49
Unconsolidated waste (above bedrock)	2.00
Consolidated waste	2.00



14.2.4.5        Equipment Parameters

14.2.4.5.1     Drilling and Blasting Equipment

Drilling and blasting operations would be a minor part of the mining system employed at the Hat Creek Mine. Two drills (one crawler and one truck-mounted drill) and one 5-t blasters' truck will be employed in these operations. Drilling and blasting would be confined to approximately 10% of the total waste materials mined.

Tables 14-6 and 14-7 provide the productivity and cost standard for the drills.

14.2.4.5.2     Loading Equipment

Hydraulic shovels will be used for loading coal and waste materials, while front-end loaders will be employed as supplementary loading equipment. Coal shovels will be equipped with 10.7 m<sup>3</sup> buckets, while the waste shovels will have 14.5 m<sup>3</sup> buckets. The smaller hydraulic shovels will be required to load waste partings and waste zones within the major coal zones of the Hat Creek Deposit. Tables 14-6 and 14-7 provide the productivity and cost standards for the shovels performing specific tasks.

It should be noted that the coal shovels will have a low use of availability. This will occur because of the widespread work areas required to blend the various coals, and it is more economical and practical to have extra pieces of equipment to cover the pit than to have long and frequent equipment moves.

14.2.4.5.3     Haulage Trucks

77-t rear dump trucks will be used for hauling coal and some waste partings, while 154-t rear dump trucks will be the primary waste haulers. These trucks were selected after an economic analysis. (See Section 9) The productivities of these trucks in Year 6 and their

cost standards are provided in Tables 14-6 and 14-7. Productivities were determined for the trucks throughout the 35-year project life to reflect the changing haulage cycles.

#### 14.2.4.5.4 Coal and Waste-handling Systems

Equipment employed in the coal and waste-handling systems include truck dump stations, control stations, distribution points, permanent and transfer conveyors, spreaders, reclaimers, stackers, crushing plant, and screens. Conveyors will be 1,400 mm wide and vary in speed from 2.5 m/s to 4.5 m/s.

The operating costs for coal and waste-handling systems are computed on an annual basis. The operating labour is fixed for a given material-handling system design operating on a given shift schedule. The maintenance labour, parts, supplies, and overhead, as well as operating supplies, are all determined as a percentage of the capital cost of the equipment.

Using this method of cost estimation, the operating cost is "step-fixed", varying only as the material-handling system design changes - such as increasing conveyor lengths and adding equipment.

Table 14-10 shows the annual operating cost development for the waste-handling system in Year 8 when the Houth Meadows Dump is being used and the second truck dump station is in operation. Annual operating costs were developed for various system designs incorporated throughout the project life, and these are reflected in the schedule of operating costs on Table 14-11.

The productivity standards shown in Table 14-6 incorporate the factors used for swell, specific gravity, fill factor, and the speed for a 90° swing cycle of a shovel. An efficiency factor of 70% was used in all productivity calculations to reflect the actual productive hours in a shift. 145 minutes of unproductive time comprised:

- (1) shift changes - 30 minutes;
- (2) lunch break - 30 minutes;
- (3) 7 x 50-minute hours, i.e. 10 minutes unproductive time per hour - 70 minutes;

(4) coffee break - 15 minutes.

The machine physical availability is defined as:

$$\frac{\text{Number of shifts the machine is mechanically available (in working condition) per year}}{\text{Scheduled working shifts/year}} \times 100\%$$

The use of availability is defined as:

$$\frac{\text{Working shifts per year}}{\text{Number of shifts the machine is mechanically available per year}} \times 100\%$$

The use of availability of a machine would be dependent on the mine operating schedule, the fleet size of the equipment, and the manpower coverage for the equipment. The effective utilization which gives an overall operating efficiency of a particular piece or type of equipment will be the multiple of the three factors above.

The effective utilization is defined as:

$$\frac{\text{Working hours}}{\text{Scheduled hours}} \times 100\%$$

TABLE 14-4

ANNUAL SALARIES OF MINE STAFF  
HAT CREEK PROJECT MINING REPORT: 1979

Position	Base Rate per annum	Payroll Burden 28%	Rate per annum
Mine Manager	56,000	16,000	72,000
Assistant Mine Manager	51,000	14,000	65,000
Superintendent, Mine	42,000	11,800	53,800
Superintendent, Plant and Maintenance	38,500	10,800	49,300
Superintendent, Engineering	38,500	10,800	49,300
Superintendent, Administration	36,000	10,100	46,100
Superintendent, Human Resources	36,000	10,100	46,100
Assistant Mine Superintendent	36,000	10,000	46,000
Assistant Maintenance Superintendent	36,000	10,000	46,000
Chief Accountant	33,000	9,200	42,200
Chief Geologist	33,000	9,200	42,200
Pit Engineer	33,000	9,200	42,200
Superintendent, Environmental and Reclamation	33,000	9,200	42,200
Senior Accountant	31,000	8,700	39,700
Purchasing Agent	31,000	8,700	39,700
Warehouse and Stores Superintendent	31,000	8,700	39,700
Personnel and Labour Relations	31,000	8,700	39,700
Senior Mine Engineer/Geologist	31,000	8,700	39,700
Chief Electrician	31,000	8,700	39,700
Master Mechanic	31,000	8,700	39,700
Environmental Pollution Engineer	31,000	8,700	39,700
Mine Shift Supervisor	31,000	8,700	39,700
Electrical/Mechanical Engineer	31,000	8,700	39,700
Mine Pit Foreman (Shift Boss)	28,500	8,000	36,500
Assay Laboratory Superintendent	28,500	8,000	36,500
Chief Surveyor	28,500	8,000	36,500
Chief Sampler	28,000	8,000	36,500
Safety Supervisor, Training	28,500	8,000	36,500
Public Relations Information	26,000	7,300	33,300
Roads and Pioneer Foreman	26,000	7,300	33,300
Crushing Plant Foreman	26,000	7,300	33,300
Payroll Accountant Cost Supervisor	26,000	7,300	33,300
Secretaries Senior, Confidential	24,000	6,700	30,700
Junior Engineer/Geologist	23,000	6,400	29,400
Chief Security Superintendent	22,000	6,200	28,200
First Aid Officer and Chief Fireman	21,000	5,900	26,900
Senior Technician/Surveying/Geology	27,000	7,600	34,600
Senior Technician Draftsman Design	25,000	7,000	32,000
Surveyor-transitman	23,000	6,400	29,400
Payroll Clerks/Warehouse Clerks	22,000	6,200	28,200
Accounting Clerks	22,000	6,200	28,200
Technicians-draftsman	21,000	5,900	26,900
First Aid Attendant/Fireman	21,000	5,900	26,900
Training Officers-Assistant	21,000	5,900	26,900
Warehouse Clerks (Shipper)	21,000	5,900	26,900
Security Guards	20,000	5,600	25,600
Samplers	19,400	5,400	24,800
Rodmen-Surveyor helper	19,400	5,400	24,800
Secretaries	18,200	5,100	23,300
Mail Truck Driver	16,000	4,500	20,500
Typists/Stenographers	15,650	4,350	20,000
Timekeeper/Mail Clerk	15,300	4,300	19,600
Keypunch Operator Payroll Clerk	15,600	4,400	20,000

TABLE 14-5

LABOUR RATES FOR MINE OPERATIONS STAFF  
(October 1979 Dollars)

Hat Creek Project Mining Report 1979

	Continuous Shift Hourly Rate <sup>1</sup>	Day Shift Hourly Rate <sup>2</sup>
Journeyman Tradesman	14.67	14.16
Shovel Operator	14.32	13.80
Waste Stacker Operator		
Crane Operator	13.98	13.45
Rotary Driller		
Coal Stacker and Reclaimer Operator		
Conveyor Controller		
Blaster	13.64	13.09
Secondary Crushing Operator		
Tireman		
Production Truck Driver	13.30	12.75
Dozer Operator		
Grader Operator		
Front-end Loader Operator		
Shovel Helper	12.95	12.39
Drill Helper		
Service Truck Driver		
Airtrac Driller		
Primary Crushing Operator		
Lube Serviceman		
Utility Truck Driver	12.61	12.04
Blaster's Helper		
Warehouseman		
Conveyor Patrolman		
Counterman	12.27	11.69
Pumpman	11.93	11.28
Labourer	11.58	10.98

<sup>1</sup> Hourly rates include: trade base rate; shift differential; overtime allowance; payroll burden.

<sup>2</sup> Hourly rates include: trade base rate; overtime allowance; payroll burden.

## PRODUCTIVITY STANDARDS FOR FUNCTIONAL COST CENTRES

100 - DRILLINGAccount item: 120 and 130 Drilling Waste MaterialPart 1

(1) Material to be drilled	- waste
(2) Drill type	- truck-mtd. auger
(3) Weighted average rate of penetration	- 25 m/h
(4) Drill pattern	- 9 m x 9 m
(5) Bench height	- 15 m
(6) Sub-grade	- 2.4 m
(7) Effective m <sup>3</sup> material/drilled $\frac{(5) \times (4)}{(6) + (5)}$	- 70 m <sup>3</sup>
(8) Efficiency factor for drilling operation (losses due to shift change, lunch break, 50-min. hour, etc.)	- 70%
<u>Productive hours per shift (apply to standard cost)</u>	
(9) No. of productive hrs. per shift (8) x 8	- 5.6
<u>Productivity in a normal working shift (apply to costing sheet - operating cost)</u>	
(10) Effective m <sup>3</sup> of material drilled per shift (7) x (3) x (9)	- 9,800 m <sup>3</sup>

Part 2

Based on mode of operation, the following factors are developed:

(11) Scheduled working shifts/machine/year, 1 shift/day, 5 days/week	- 249
(12) Machine physical availability - <u>No. of hrs. machine available for operation</u> Scheduled working hrs. in pit	- 80%
(13) Use of availability - <u>No. of hrs. machine manned &amp; available for production</u> No. of hrs. machine available for operation	- 90%
<u>Production from one machine (apply to costing sheet - capital cost)</u>	
(14) No. of productive shifts per year (11) x (12) x (13)	- 179
(15) Effective m <sup>3</sup> of material drilled off per year (10) x (14)	- 1,754,000 m <sup>3</sup>

Account item: 220 and 230 Blasting Waste Material

Blasting productivity in a normal working shift is equal to drilling productivity.

Productivity in a normal working shift (apply to costing sheet - operating cost)

- |   |                          |
|---|--------------------------|
| (1) Effective m <sup>3</sup> of material blasted per shift<br>(see drilling productivity #10) | - 9,800 m <sup>3</sup>   |
| (2) No. of holes drilled per shift -<br><u>(1)</u><br>Drill pattern x bench height            | - 8                      |
| (3) Powder factor   | - 0.19 kg/m <sup>3</sup> |
| (4) Explosives required per hole -<br>Drill pattern x bench height x (3)                      | - 231 kg                 |
| (5) Explosives required per shift (4) x (2)<br>(apply to standard cost)                       | - 1,848 kg               |

Account item: 310 Loading Coal (10.7 m<sup>3</sup> Hydraulic Shovel)

Part 1

(1) Maximum-rated suspended load - heavy lift circuit	- 37,921 kg
(2) Bucket weight - bottom dump	- 22,226 kg
(3) Maximum payload	- 15,695 kg
(4) Bucket capacity	- 10.7 m <sup>3</sup>
(5) Average in-situ density of material	- 1,490 kg/bank m <sup>3</sup>
(6) Swell % (>100%)	- 135%
(7) Swell factor $\frac{1}{(6)}$	- 0.74
(8) Fill factor	- 0.90
(9) Bucket factor (7) x (8)	- 0.67
(10) Bank m <sup>3</sup> per cycle (4) x (9)	- 7.2 bank m <sup>3</sup>
(11) Average cycle time	- 32 s
(12) No. of cycles/hour	- 113
(13) Theoretical output (10) x (12)	- 814 bank m <sup>3</sup>
(14) Efficiency factor for loading operations (losses due to shift changes, lunch break, 50-min. hour, etc.)	- 70%
<u>Productive hours per shift (apply to standard cost)</u>	
(15) No. of productive hours per shift (14) x 8	- 5.6
<u>Productivity in a normal working shift (apply to costing sheet - operating cost)</u>	
(16) Bank m <sup>3</sup> of material loaded per shift (13) x (15)	- 4,558 bank m <sup>3</sup> (6,791 t)

Part 2

Based on mode of operation, the following factors are developed:

(17) Scheduled working shifts/machine/year	- 1,062
(18) Machine physical availability	- 80%
(19) Use of availability	- 75%
<u>Production from one machine (apply to costing sheet - capital cost)</u>	
(20) No. of productive shifts per year (17) x (18) x (19)	- 637
(21) Bank m <sup>3</sup> of material loaded per year (16) x (20)	- 2.9 million bank m <sup>3</sup> (4.3 million t)

Note: Check that (10) x (5) does not exceed (3)  
7.2 x 1,490 = 10,728 < 15,695



Account item: 320 Loading Consolidated Waste Partings  
(10.7 m<sup>3</sup> Hydraulic Shovel)

Part 1

(1) Maximum-rated suspended load	- 37,921 kg
(2) Bucket weight	- 22,226 kg
(3) Maximum payload	- 15,695 kg
(4) Bucket capacity	- 8.0 m <sup>3</sup>
(5) Average in-situ density of material	- 2,000 kg/bank m <sup>3</sup>
(6) Swell % (>100%)	- 130%
(7) Swell factor $\frac{1}{(6)}$	- 0.77
(8) Fill factor	- 0.90
(9) Bucket factor (7) x (8)	- 0.69
(10) Bank m <sup>3</sup> per cycle (4) x (9)	- 5.5 bank m <sup>3</sup>
(11) Average cycle time	- 32 s
(12) No. of cycles/hour	- 113
(13) Theoretical output (10) x (12)	- 622 bank m <sup>3</sup> /h
(14) Efficiency factor for loading operations (losses due to shift changes, lunch break, 50-min. hour, etc.)	- 70%

Productive hours per shift (apply to standard cost)

(15) No. of productive hours per shift (14) x 8	- 5.6
---	-------

Productivity in a normal working shift (apply to costing sheet - operating cost)

(16) Bank m <sup>3</sup> of material loaded per shift (13) x (15)	- 3,483 bank m <sup>3</sup>
---	-----------------------------

Part 2

Based on mode of operation, the following factors are developed:

(17) Scheduled working shifts/machine/year	- 1,062
(18) Machine physical availability	- 80%
(19) Use of availability	- 75%

Production from one machine (apply to costing sheet - capital cost)

(20) No. of productive shifts per year (17) x (18) x (19)	- 637
(21) Bank m <sup>3</sup> of material loaded per year (16) x (20)	- 2.22 million bank m <sup>3</sup>

Note: Check that (10) x (5) does not exceed (3)  
 5.5 x 2,000 = 11,000 < 15,695

Account item: 320 and 330 Loading All Waste Materials  
(14.5 m<sup>3</sup> Hydraulic Shovel) (except waste partings)

Part 1

(1) Maximum-rated suspended load	-
(2) Bucket weight	-
(3) Maximum payload	-
(4) Bucket capacity	- 14.5 m <sup>3</sup>
(5) Average in-situ density of material	- 2,000 kg/bank m <sup>3</sup>
(6) Swell % (>100%)	- 125%
(7) Swell factor $\frac{1}{(6)}$	- 0.8
(8) Fill factor	- 0.9
(9) Bucket factor (7) x (8)	- 0.72
(10) Bank m <sup>3</sup> per cycle (4) x (9)	- 10.4 bank m <sup>3</sup>
(11) Average cycle time	- 35 s
(12) No. of cycles/hour	- 103
(13) Theoretical output (10) x (12)	- 1,071 bank m <sup>3</sup> /h
(14) Efficiency factor for loading operations (losses due to shift changes, lunch break, 50-min. hour, etc.)	- 0.70
<u>Productive hours per shift</u> (apply to standard cost)	
(15) No. of productive hours per shift (14) x 8	- 5.6
<u>Productivity in a normal working shift</u> (apply to costing sheet - operating cost)	
(16) Bank m <sup>3</sup> of material loaded per shift (13) x (15)	- 5,998 bank m <sup>3</sup>

Part 2

Based on mode of operation, the following factors are developed:

(17) Scheduled working shifts/machine/year	- 1,062
(18) Machine physical availability	- 80%
(19) Use of availability	- 95%
<u>Production from one machine</u> (apply to costing sheet - capital cost)	
(20) No. of productive shifts per year (17) x (18) x (19)	- 807
(21) Bank m <sup>3</sup> of material loaded per year (16) x (20)	- 4.84 million bank m <sup>3</sup>

Note: The 14.5 m<sup>3</sup> standard bucket is suitable for bulk material weights less than 1.8 t/m<sup>3</sup>. Bulk material weight of waste is (5) x (7) - 1.6 t/m<sup>3</sup>.

Account item: 410 Hauling Coal (Year 6)  
Loading Shovel: 10.7 m<sup>3</sup> Hydraulic Shovel

Part 1

- (1) Capacity of trucks (77.3 m<sup>3</sup> struck capacity coal box) - 77 t  
 (2) Material to be handled: - coal  
     (a) average in-situ density of material - 1,490 kg/bank m<sup>3</sup>  
     (b) bank m<sup>3</sup> per shovel load (see loading equipment analysis) - 7.2 bank m<sup>3</sup>  
 (3) No. of shovel loads/truck load  
      $\frac{(1)}{(2a)} \times \frac{1,000}{1} \times \frac{1}{(2b)}$  (nearest lower whole number) - 7  
 (4) Actual capacity per truck load - (3) x (2b) - 50.4 bank m<sup>3</sup>  
 (5) Determination of fixed time per cycle:  
     (a) waiting and spotting time - 30 s  
     (b) loading time (30) x cycle time per shovel load (see loading equipment analysis) 7 x 32 - 224 s  
     (c) turning and dumping time - 78 s  
     Total fixed time  $\frac{a + b + c}{60}$  mins. - 5.53 mins.  
 (6) Average hauling time (Year 6) - 8.95 mins.  
 (7) Average cycle time (5) + (6) - 14.48 mins.  
 (8) Theoretical output (4) x  $\frac{60}{(7)}$  - 208.8 bank m<sup>3</sup>/h  
 (9) Efficiency factor for hauling operations (losses due to shift changes, lunch break, 50-min. hour, etc.) - 70%  
Productive hours per shift (apply to standard costs)  
 (10) No. of productive hours per shift (9) x 8 - 5.6  
Productivity in a normal working shift (apply to costing sheet - operating cost)  
 (11) Bank m<sup>3</sup> of material hauled per shift (8) x (10) - 1,169 bank m<sup>3</sup>  
     (1,742 t)

Part 2

Based on mode of operation, the following factors are developed:

- (12) Scheduled working shifts/truck/year - 1,062  
 (13) Machine physical availability - 73%  
 (14) Use of availability - 95%  
Production from one machine (apply to costing sheet - capital cost)  
 (15) No. of productive shifts per year (12) x (13) x (14) - 737  
 (16) Bank m<sup>3</sup> of material hauled in Year 6 (11) x (15) - 861,553 bank m<sup>3</sup>  
     (1,283,714 t)  
 Note: Productive hours per annum - 737 x 5.6 = 4,127

Account item: 420 Hauling Consolidated Waste Partings (Year 6)  
Loading Shovel: 10.7 m<sup>3</sup> Hydraulic Shovel

Part 1

- (1) Capacity of trucks (77.3 m<sup>3</sup> struck capacity coal box) - 77 t  
 (2) Material to be handled: - consolidated waste  
     (a) average in-situ density of material - 2,000 kg/bank m<sup>3</sup>  
     (b) bank m<sup>3</sup> per shovel load (see loading equipment analysis) - 5.5 bank m<sup>3</sup>  
 (3) No. of shovel loads/truck load  
 $\frac{(1)}{(2a)} \times \frac{1,000}{1} \times \frac{1}{(2b)}$  (nearest lower whole number) - 7  
 (4) Actual capacity per truck load - (3) x (2b) - 38.5 bank m<sup>3</sup>  
 (5) Determination of fixed time per cycle:  
     (a) waiting and spotting time - 30 s  
     (b) loading time (3) x cycle time per shovel load (see loading equipment analysis) 7 x 32 - 224 s  
     (c) turning and dumping time - 78 s  
 Total fixed time  $\frac{a + b + c}{60}$  mins. - 5.53 mins.  
 (6) Average hauling time (Year 6) - 8.95 mins.  
 (7) Average cycle (5) + (6) - 14.48 mins.  
 (8) Theoretical output (4) x  $\frac{60}{(7)}$  - 159.5 bank m<sup>3</sup>/h  
 (9) Efficiency factor for hauling operations (losses due to shift changes, lunch break, 50-min. hour, etc.) - 70%  
Productive hours per shift (apply to standard costs)  
 (10) No. of productive hours per shift (9) x 8 - 5.6  
Productivity in a normal working shift (apply to costing sheet - operating cost)  
 (11) Bank m<sup>3</sup> of material hauled per shift (8) x (10) - 893 bank m<sup>3</sup>

Part 2

Based on mode of operation, the following factors are developed:

- (12) Scheduled working shifts/truck/year - 1,062  
 (13) Machine physical availability - 73%  
 (14) Use of availability - 95%  
Production from one machine (apply to costing sheet - capital cost)  
 (15) No. of productive shifts per year (12) x (13) x (14) - 737  
 (16) Bank m<sup>3</sup> of material hauled in Year 6 (11) x (15) - 658,141 bank m<sup>3</sup>

Account item: 420 and 430 Hauling All Waste Materials (Year 6)  
Loading Shovel: 14.5 m<sup>3</sup> Hydraulic Shovel (except waste partings)

Part 1

- |  |  |
|--|--|
| (1) Capacity of trucks (90.2 m <sup>3</sup> struck capacity rock box)  | - 154 t  |
| (2) Material to be handled:  | - all waste materials<br>(except waste partings) |
| (a) average in-situ density of material  | - 2,000 kg/bank m <sup>3</sup>                   |
| (b) bank m <sup>3</sup> per shovel load (see loading equipment analysis)                                     | - 10.4 bank m <sup>3</sup>                       |
| (3) No. of shovel loads/truck load   |  |
| $\frac{(1)}{(2a)} \times \frac{1,000}{1} \times \frac{1}{(2b)}$ (nearest lower whole number)                 | - 7  |
| (4) Actual capacity per truck load - (3) x (2b)  | - 72.8 bank m <sup>3</sup>                       |
| (5) Determination of fixed time per cycle:   |  |
| (a) waiting and spotting time  | - 30 s   |
| (b) loading time (3) x cycle time per shovel load (see loading equipment analysis) 7 x 35                    | - 245 s  |
| (c) turning and dumping time   | - 83 s   |
| Total fixed time $\frac{a + b + c}{60}$ mins.  | - 5.97   |
| (6) Average hauling time (Year 6)  | - 8.58 mins.                                     |
| (7) Average cycle time (5) + (6)   | - 14.55 mins.                                    |
| (8) Theoretical output (4) x $\frac{60}{(7)}$  | - 300.2 bank m <sup>3</sup> /h                   |
| (9) Efficiency factor for hauling operations (losses due to shift changes, lunch break, 50-min. hours, etc.) | - 70%  |
| <u>Productive hours per shift (apply to standard cost)</u>   |  |
| (10) No. of productive hours per shift (9) x 8   | - 5.6  |
| <u>Productivity in a normal working shift (apply to costing sheet - operating cost)</u>                      |  |
| (11) Bank m <sup>3</sup> of material hauled per shift (8) x (10)   | - 1,681 bank m <sup>3</sup>                      |

Part 2

Based on mode of operation, the following factors are developed:

- |  |                                 |
|--|---------------------------------|
| (12) Scheduled working shifts/truck/year                                   | - 1,062                         |
| (13) Machine physical availability   | - 73%                           |
| (14) Use of availability   | - 95%                           |
| <u>Production from one machine (apply to costing sheet - capital cost)</u> |                                 |
| (15) No. of productive shifts per year (12) x (13) x (14)                  | - 737                           |
| (16) Bank m <sup>3</sup> of material hauled in Year 6 (11) x (15)          | - 1,238,897 bank m <sup>3</sup> |

## STANDARD COSTS FOR FUNCTIONAL COST CENTRES

100 - DRILLINGAccount item: 120 and 130 Drilling Waste Material

Expense or Position Title	Basic Unit	Price Per Unit	Units Per Shift	Total Cost Per Shift	Man-Shifts Per Productive Shift
<u>Operating Labour</u>					
(a) Operator	MH	13.45	8.00	107.60	1.32
(b) Helper/Oiler	MH	12.39	8.00	99.12	1.32
Subtotal				206.72	
<u>Operating Supplies</u>					
(a) Fuel	litre	0.17	344.40	58.55	
(b) Wear Parts				17.01	
Subtotal				75.56	
Total Operating				282.28	
<u>Maintenance Labour</u>					
(a) Repair	MH	14.67	4.03	59.12	0.50
(b) Service	MH	12.95	0.50	6.48	0.06
Subtotal				65.60	
<u>Maintenance Parts and Supplies</u>					
(a) Repair	\$			104.85	
(b) Tires	\$			13.10	
Subtotal				117.95	
<u>Maintenance Overhead</u>					
(a) Staff	\$/repair labour hour	2.52	4.03	10.16	
(b) Repair	MH	14.67	0.48	7.04	0.06
(c) Supplies	\$			16.19	
Subtotal				33.39	
Total Maintenance				216.94	
Total Operating and Maintenance Cost/Shift:				\$499.22	

Account item: 220 and 230 Blasting Waste Material

Expense or Position Title	Basic Unit	Price Per Unit	Units Per Shift	Total Cost Per Shift	Man-Shifts Per Productive Shift
<u>Operating Labour</u>					
(a) Operator	MH	13.09	8.00	104.72	1.32
(b) Helper/Oiler	MH	12.04	8.00	<u>96.32</u>	
Subtotal				201.04	
<u>Operating Supplies</u>					
(a) Fuel	litre	0.17	65.06	11.06	
(b) Explosives	kg	0.62	1,848	<u>1,145.76</u>	
Subtotal				<u>1,156.82</u>	
Total Operating				<u>1,357.86</u>	
<u>Maintenance Labour</u>					
(a) Repair	MH	14.67	1.74	25.52	0.22
(b) Service	MH	12.95	0.25	<u>3.24</u>	0.03
Subtotal				28.76	
<u>Maintenance Parts and Supplies</u>					
(a) Repair	\$			22.12	
(b) Tires	\$			<u>6.89</u>	
Subtotal				29.01	
<u>Maintenance Overhead</u>					
(a) Staff	\$/repair labour hour	2.52	1.74	4.38	
(b) Repair	MH	14.67	0.21	3.08	0.03
(c) Supplies	\$			<u>6.91</u>	
Subtotal				<u>14.37</u>	
Total Maintenance				<u>72.14</u>	
Total Operating and Maintenance Cost/Shift:				\$1,430.00	

Account item: 310 and 320 Loading Coal and Consolidated Waste  
Partings with 10.7 m<sup>3</sup> Hydraulic Shovel

Expense or Position Title	Basic Unit	Price Per Unit	Units Per Shift	Total Cost Per Shift	Man-Shifts Per Productive Shift
<u>Operating Labour</u>					
(a) Operator	MH	14.32	10.56	151.22	1.32
(b) Helper/Oiler					
Subtotal				<u>151.22</u>	
<u>Operating Supplies</u>					
(a) Wear Parts (teeth, etc.)	\$			50.10	
(b) Power	kW	0.02	1656.5	<u>33.13</u>	
Subtotal				<u>83.23</u>	
Total Operating				<u>234.45</u>	(201.32) excl. power
<u>Maintenance Labour</u>					
(a) Repair	MH	14.67	10.08	147.87	1.26
(b) Service	MH	12.95	0.50	<u>6.48</u>	0.06
Subtotal				<u>154.35</u>	
<u>Maintenance Parts and Supplies</u>					
(a) Repairs	\$			<u>200.86</u>	
Subtotal				<u>200.86</u>	
<u>Maintenance Overhead</u>					
(a) Staff	\$/repair labour hour	2.52	10.08	25.40	
(b) Repair	MH	14.67	1.21	17.75	0.15
(c) Supplies	\$			<u>40.31</u>	
Subtotal				<u>83.46</u>	
Total Maintenance				<u>438.67</u>	
Total Operating and Maintenance Cost/Shift:				\$673.12/\$639.99 (excl. power)	



Account item: 320 and 330 Loading All Waste Material (except waste partings) with 14.5 m<sup>3</sup> Hydraulic Shovel

Expense or Position Title	Basic Unit	Price Per Unit	Units Per Shift	Total Cost Per Shift	Man-Shifts Per Productive Shift
<u>Operating Labour</u>					
(a) Operator	MH	14.32	10.56	151.22	1.32
(b) Helper/Oiler	MH	12.95	10.56	<u>136.75</u>	1.32
Subtotal				287.97	
<u>Operating Supplies</u>					
(a) Wear Parts	\$			66.31	
(b) Power	kW	0.02	2486.5	<u>49.73</u>	
Subtotal				<u>116.04</u>	
Total Operating				<u>404.01</u>	(354.28) excl. power
<u>Maintenance Labour</u>					
(a) Repair	MH	14.67	11.20	164.30	1.40
(b) Service	MH	12.95	0.50	<u>6.48</u>	0.06
Subtotal				170.78	
<u>Maintenance Parts and Supplies</u>					
(a) Repair	\$			<u>295.33</u>	
Subtotal				295.33	
<u>Maintenance Overhead</u>					
(a) Staff	\$/repair labour hour	2.52	11.20	28.22	
(b) Repair	MH	14.67	1.34	19.66	0.17
(c) Supplies	\$			<u>44.86</u>	
Subtotal				<u>92.74</u>	
Total Maintenance				<u>558.85</u>	
Total Operating and Maintenance Cost/Shift:				<u>\$962.86/\$913.13 (excl. power)</u>	

Account item: 410 and 420 Hauling Coal and Consolidated Waste  
Partings with 77-t Rear Dump Truck

Expense or Position Title	Basic Unit	Price Per Unit	Units Per Shift	Total Cost Per Shift	Man-Shifts Per Productive Shift
<u>Operating Labour</u>					
(a) Operator	MH	13.30	8.00	106.40	1.00
(b) Helper/Oiler					
Subtotal				<u>106.40</u>	
<u>Operating Supplies</u>					
(a) Fuel	litre	0.17	437.60	<u>74.39</u>	
Subtotal				<u>74.39</u>	
Total Operating				<u>180.79</u>	
<u>Maintenance Labour</u>					
(a) Repair	MH	14.67	5.60	82.15	0.70
(b) Service	MH	12.95	0.50	<u>6.48</u>	0.06
Subtotal				<u>88.63</u>	
<u>Maintenance Parts and Supplies</u>					
(a) Repair	\$			123.97	
(b) Tires	\$			<u>51.52</u>	
Subtotal				<u>175.49</u>	
<u>Maintenance Overhead</u>					
(a) Staff	\$/repair labour hour	2.52	5.60	14.11	
(b) Repair	MH	14.67	0.67	9.83	0.08
(c) Supplies	\$			<u>22.43</u>	
Subtotal				<u>46.37</u>	
Total Maintenance				<u>310.49</u>	
Total Operating and Maintenance Cost/Shift:				<u>\$491.28</u>	

## 400 - HAULING

Sheet 6 of 6

Account item: 420 and 420 Hauling All Waste Materials (except waste partings) with 154-t Rear Dump Truck

Expense or Position Title	Basic Unit	Price Per Unit	Units Per Shift	Total Cost Per Shift	Man-Shifts Per Productive Shift
<u>Operating Labour</u>					
(a) Operator	MH	13.30	8.00	106.40	1.00
(b) Helper/Oiler					
Subtotal				<u>106.40</u>	
<u>Operating Supplies</u>					
(a) Fuel	litre	0.17	585.00	<u>99.45</u>	
Subtotal				<u>99.45</u>	
Total Operating				<u>205.85</u>	
<u>Maintenance Labour</u>					
(a) Repair	MH	14.67	7.56	110.91	0.95
(b) Service	MH	12.95	0.50	<u>6.48</u>	0.06
Subtotal				<u>117.39</u>	
<u>Maintenance Parts and Supplies</u>					
(a) Repair	\$			191.10	
(b) Tires	\$			<u>119.62</u>	
Subtotal				<u>310.72</u>	
<u>Maintenance Overhead</u>					
(a) Staff	\$/repair labour hour	2.52	7.56	19.05	
(b) Repair	MH	14.67	0.91	13.31	0.11
(c) Supplies	\$	4.00		<u>30.24</u>	
Subtotal				<u>62.60</u>	
Total Maintenance				<u>490.71</u>	
Total Operating and Maintenance Cost/Shift:				<u>\$696.56</u>	

CAPITAL COSTS

The capital cost estimate for the recommended mining scheme was prepared in accordance with the following major cost centres:

Engineering and Construction Costs;  
Mine Property Development;  
Buildings and Structures;  
Mining Equipment;  
Coal Conveying, Crushing and Blending Equipment;  
Low-grade Coal Beneficiation Equipment;  
Waste Disposal Equipment;  
Reclamation and Environmental Protection;  
Contingency.

Table 14-9 summarizes the project cash flow of capital costs for these nine major cost centres over the five-year pre-production period, 35-year production period, and 10-year post-production reclamation period. The cash flow of mine equipment capital costs was developed according to the system shown in Figure 14-1. The capital costs and service lives of equipment presented in Table 14-3, and the equipment productivity standards presented in Table 14-6, were the main sources of input in developing these cash flows.

Table 14-8 presents sample calculations for the development of capital costs for loading and haulage equipment.

14.3.1 Description of Costs Included in the Major Cost Centres

14.3.1.1 Engineering and Construction (Account Code 90000)

The engineering and construction costs include the capital costs of project management and design, pre-production survey and drilling, and construction costs. Included in the construction costs is the operating cost of a construction ramp at \$18.00 per man-day. The construction schedule is shown in Section 12.

14.3.1.2 Mine Property Development (Account Code 91000)

The mine property development costs are the construction costs of the permanent roads in the service area, the mine water supply, sewer and drainage systems, in-pit electrical distribution, fuel distribution station, pit communications (radio and telephone), and the estimated costs of site improvements. Not included in the development estimates are the costs of land and mineral rights purchase.

14.3.1.3 Buildings and Structures (Account Code 92000)

The buildings and structures costs include the capital costs of the following:

- (1) Administration and Office Building;
- (2) Maintenance shops and Warehouse;
- (3) Mine Dry;
- (4) Mine service buildings;
- (5) Bulk Fuel and Lube Storage;

- (6) Equipment and furnishings for the buildings during the project life.

The cost of these buildings are estimated on a unit cost basis per square metre of floor area.

No allowances have been made for a townsite, the construction of off-site housing, or on-site accommodation of mine personnel at any stage of construction or operation.

14.3.1.4 Mining Equipment (Account Code 93000)

The estimated mining equipment costs are the initial and capital replacement costs of all mobile mining equipment, auxiliary and support equipment, and initial spare parts.

14.3.1.5 Coal Conveying, Crushing, and Blending Equipment  
(Account Code 94000)

The costs in this account include the capital costs of:

- Coal conveyors within the pit;
- Truck dump station equipment;
- Overland coal conveyor;
- Crushing Plant;
- Transfer conveyors, conveyors in the blending area, stackers, reclaimers, transfer car, sampling system, and weigh scale;
- Initial spare parts;
- Construction costs of truck dump stations, overpasses, crusher and transfer houses, conveyor corridors, access roads, and conveyor supports.

14.3.1.6 Low-grade Coal Beneficiation Equipment (Account Code 95000)

The costs in this account include the capital costs of:

- The low-grade coal conveyor within the pit;
- Truck dump station equipment;
- Low-grade coal plant equipment including screens, crushers, bulk density meters, surge bins and reject conveyors;
- Initial spare parts;
- Construction costs of the truck dump station, conveyor corridors and supports.

14.3.1.7 Waste Disposal Equipment (Account Code 96000)

The estimated waste disposal costs are the capital costs of:

- Waste conveyors within the pit;
- Truck dump station equipment;
- Overland waste conveyors;
- Waste dump transfer conveyors, shiftable conveyors, portable belt conveyors, trippers, and spreaders;
- Initial spare parts;
- Construction costs of conveyor foundations and supports, conveyor corridors, service roads, and truck dump stations.

14.3.1.8 Reclamation and Environmental Protection (Account Code 97000)

The costs in this account include the initial capital costs of the reclamation complex, including greenhouses, machinery shed, and equipment for these buildings, and the estimated initial capital and replacement costs of light vehicles, agricultural equipment, laboratory and testing equipment, office equipment, and seed and plant stock.

14.3.1.9 Contingency (Account Code 98000)

The contingency allowance was developed following assessment of the variable risks involved in the major cost centres, as well as consideration of the degree of completeness of cost information, and the labour portion of the cost.

A low risk factor was applied to mobile mining equipment, conveying equipment, and vehicles, since it was considered possible that the preliminary manufacturers' budget quotations for these items could be improved upon at the time of purchase. Higher risk factors were applied to cost centres involving high labour content such as construction work.

The total estimated contingency was based on the following factors:

<u>Category</u>	<u>Contingency Factor</u>
All equipment employed in the mining operations;	10%
Buildings and structures, insurance, and construction costs, and project management and engineering costs.	15%

The contingency allowance provides only for those risks described above, and is not intended to be a provision against unforeseeable risks such as foreign exchange fluctuations on foreign purchases, lengthy industrial disruptions, or events of force majeure of any type.







OPERATING COSTS

The operating cost estimate for the recommended mining schemes was prepared in accordance with the following major cost centres:

Drilling;

Blasting;

Loading;

Hauling;

Coal-handling System (truck dump stations to powerplant);

Waste-handling System (truck dump stations to waste dumps);

Auxiliary Equipment;

Power;

General Mine Expense;

Overhead;

Royalties;

Contingency;

Contractor's Allowance.

Table 14-11 summarizes the project cash flow of operating costs for these 13 major cost centres over the five-year pre-production period, 35-year production period, and 10-year post-production reclamation period. Pre-production operating costs were not transferred to capital costs. The cash flow of operating costs was developed according to the system shown in Figures 14-1, 14-2, and 14-3. Operating cost estimating criteria shown in Tables 14-4 to 14-7 were the main sources of input in developing these cash flows.

Table 14-10 shows the development of operating costs for the functional cost centres, drilling, blasting, loading, hauling, and waste-handling.

14.4.1            Description of Costs Included in the Major Cost Centres

14.4.1.1        Drilling and Blasting (Account Codes 100 and 200)

The costs in these accounts include the operating costs for drilling and blasting approximately 10% of the waste materials mined from the open pit. Tests on the strength of the waste and coal materials in the Hat Creek Deposit indicate that the hydraulic shovels employed for loading operations will be capable of digging almost all materials with no prior blasting. An allowance has therefore been made only for isolated areas of consolidated waste materials that would require blasting.

14.4.1.2        Loading and Hauling (Account Codes 300 and 400)

The costs in these accounts are the costs of operating the hydraulic shovels and the waste and coal rear dump trucks for the loading and hauling of coal and waste materials to the truck unloading stations. Provision has been made for the continual removal of topsoil by scrapers as the pit expands. In addition, scrapers will remove 2.2 million bank m<sup>3</sup> of overburden in the pre-production period to establish suitable working benches for the hydraulic shovels and trucks.

14.4.1.3        Coal and Waste-handling Systems (Account Codes 500 and 600)

Material-handling costs are the operating costs incurred in conveying waste to the waste dumps and coal material to the power-plant. These costs can be broken into the following components:

1. Conveying Waste

This covers the operating cost of the waste-conveying system and the dump-handling system. The costs of relocating the dump-conveying systems as the dumps are developed are also included.

## 2. Conveying Coal

This includes the operating costs of the inclined coal conveyor, truck dump stations, the crushing plant, the overland conveyor to the generating station, and the low-grade coal-handling equipment.

## 3. Coal Stockpiling and Blending

This includes the operating costs of the stackers, reclaimers, conveyors, and clean-up equipment within the stockpiling and blending area.

### 14.4.1.4 Auxiliary Equipment (Account Code 700)

This includes the operating costs of front-end loaders, dozers, graders, small trucks, compactors, and traxcavators employed in a wide variety of operations, which include embankment construction for the waste dumps, causeway construction, levelling on dumps, pushing and compacting stockpiles, bench pioneering, clean-up work, and assisting loading and hauling equipment. These costs also allow for the initial construction of the Medicine Creek Dump in Years 12, 13, and 14.

### 14.4.1.5 Power (Account Code 800)

The annual kwh consumption was determined for the shovels and material-handling equipment. The power costs were then developed based on a rate of 20 mills/kW.h.

### 14.4.1.6 General Mine Expense (Account Code 900)

The general mine expense includes the operating costs of 14 account items which are described below:

### 1. Pit Dewatering and Drainage

This provides for the installation, operation, and maintenance of the pit dewatering well system and in-pit sumps. Two well systems are required, the first to operate from the pre-production period to Year 15, and the second system to be phased in between Year 10 and Year 15 as the first well system is mined out. Costs allow for repair and replacement of pumps, piping, tankage, well monitoring, and relocation costs of headers and piping as required to support pit development.

### 2. Electrical Maintenance

This includes the cost of repairs, routine maintenance, and periodic moves of the in-pit overhead power distribution system, power distribution system of the dumps, and dewatering. This account also includes the maintenance of all site electrical services and the handling, repair, and replacement of trailing cables for shovels, conveyors, stackers, and reclaimers.

### 3. Road Construction and Maintenance

This includes the costs of digging, loading, hauling, placing, and compacting suitable road bases and surface materials, and the additional costs of crushing road surface materials as required for the construction of roads in and around the pit and dumps. These roads are necessary for truck and conveyor access. These costs also allow for snow removal and spreading calcium chloride on all roads.

### 4. Mine Service Vehicles and Equipment

This includes the costs of operating mine service vehicles such as cranes, service trucks, tire truck, mobile cable reelers, vulcanizing equipment, steam cleaners, lo-boy and hi-boy, Hiab cranes, and forklifts.

### 5. Field Lubrication/Fuelling

This includes the cost of operating labour and supplies, and repair labour and parts for the operation of the main fuel dump and in-pit fuelling station. Also included are the operating costs of fuel and lube trucks.

### 6. Reclamation and Environmental Protection

This includes the costs of staff, maintenance of greenhouses and storage buildings, stripping and stockpiling of surface

soils, surface regrading, placement of buffer materials and growth media, revegetation and subsequent maintenance.

#### 7. Mine Supervision

This provides for the salaries and expenses of the mine superintendent, shift supervisors, shift foremen, together with stenographic and clerical personnel.

#### 8. Mine Engineering and Geology

This includes the salaries and expenses of the superintendent of mine engineering, pit engineer, planning engineers, senior mine geologist, geologists and technicians, survey supervisor and crews, samplers, coal-quality control technicians, together with stenographic and clerical personnel.

#### 9. Maintenance Engineering

This includes the salaries and expenses of the maintenance superintendent; the design group, consisting of a mechanical engineer, an electrical engineer, and draftsmen; the electrical maintenance supervisors, consisting of the chief electrician, shop foremen, and shift foremen; and the clerical and stenographic staff required in support of these functions. All other costs for maintenance personnel have been allocated to the maintenance costs of the mine equipment or are included in the account item, "Electrical Maintenance".

#### 10. Mine Communications

This includes the salaries of dispatchers and repair technicians, the costs of radio repair parts, and the annual replacement cost of truck and portable radios.

#### 11. Mine Transportation I

This includes the operating and maintenance costs of personnel buses providing daily transport from the dry to the mine.

#### 12. Mine Transportation II

This includes the operating costs of light vehicles assigned to the mine supervisory and technical personnel.

### 13. Mine Training

This provides for the salaries and expenses of mine training officers, the wages of hourly paid personnel while in training, the costs of training supplies, staff supervisory training and courses.

### 14. Close-Spaced In-Pit Drilling

This includes the cost of operating drilling equipment for quality-control drilling.

#### 14.4.1.7 Overhead (Account Code 1000)

Overhead costs comprise the operating costs of the following groups:

- (1) Management;
- (2) Administration;
- (3) Administration Services;
- (4) Administration Site Services;
- (5) Human Resources;
- (6) Local Taxes and Insurance.

These six groups are described below.

#### 1. Management Group

This provides for the salaries and expenses of the mine manager, assistant mine manager, supervisor of industrial engineering, industrial and contract engineers, public relations officer, chief chemist, assayers, together with stenographic and secretarial personnel.

#### 2. Administration

This provides for the salaries and expenses of the administration superintendent, accountants, purchasing agents, expeditors, warehouse supervisor, stores foremen, and the clerical and stenographic staff required in support of these functions.



### 3. Administration Services

This provides for the salaries and expenses of systems analysts, programmers, security officers and supervisors, fire chief and deputy fire chief, janitors, carpenters, painters, and exchange operators. Also included are the operation and maintenance of the fire trucks and fire extinguishing equipment.

### 4. Administration Site Services

This provides for the costs of operating and maintaining the following site services:

- Mine Dry, including cost of utilities and supplies, maintenance labour and supplies;
- Plant yard, roads, and parking areas;
- Delivery truck operating between the mine site and local communities;
- Garbage truck for garbage removal from mine site and service area;
- Water treatment plant, water distribution system, sewage disposal system, and treatment lagoons.

An allowance for overtime meals is also included in this account.

### 5. Human Resources

This provides for the salaries and expenses of the superintendent of human resources, the personnel supervisor and officers, labour relations supervisor, safety supervisor, first-aid supervisor and attendants, and the stenographic and clerical personnel associated with these functions. Also included is the cost of operating an ambulance.

### 6. Local Taxes and Insurance

This provides for the payments of local taxes or grants in lieu of taxes to the municipality and premiums for all-risk insurance. The allowance for local taxes was calculated at 0.5% of fixed assets, and insurance was assessed at an average annual rate of 0.25% of total capital asset value.

14.4.1.8      Royalties (Account Code 1100)

Government regulations stipulate royalty payments as 3½% of the mine-head value. In this preliminary engineering report, royalty payments are estimated at \$0.35 per tonne mined.

14.4.1.9      Contingency (Account Code 1200)

In developing the operating costs, the variable risks associated with each of the major cost centres have been accounted for. For example, a higher risk assumption was considered necessary in the hourly paid labour categories, where availability of qualified personnel can vary widely depending on market conditions. Repair labour is also subject to additional risk proportionate to the degree of care exercised in the operation of the equipment.

A contingency allowance of 10% was applied to these operating costs to cater for the potential risks involved in the major cost categories. This contingency is not intended to cover unforeseeable risks such as major labour disruptions or events of force majeure of any kind.

14.4.1.10     Contractor's Allowance (Account Code 1300)

A contractor's allowance of 10% was applied to all operating costs except for the major cost centres, power, and royalties. This allowance provides for contractor's overhead and profit should operation of the mine be contracted. No additional allowance has been made for the additional staff the owner would require for monitoring and control of the contractor.

TABLE 14-10

Sheet 1 of 10

DEVELOPMENT OF OPERATING COSTS FOR FUNCTIONAL COST CENTRES: 100 - DRILLINGAccount item: 120 and 130 Drilling Waste Material

	(1)	(2)	(3)	(4)	(5)
Year	Task Bank m <sup>3</sup> Mat. to be Drilled (fr. Prod. Sched.) (x10 <sup>3</sup> )	Productivity Bank m <sup>3</sup> Mat. Drilled Per Shift (fr. Prod. Stds.)	No. of Shifts Required (1) ÷ (2)	\$ Cost/Shift (fr. Cost Std.)	\$ Total Annual Cost (x10 <sup>3</sup> ) (3) x (4)
-2					
-1	400	9,800	41	499.22	20
1	400	9,800	41	499.22	20
2	700	9,800	71	499.22	35
3	1,000	9,800	102	499.22	51
4	1,500	9,800	153	499.22	76
5	1,500	9,800	153	499.22	76
6	1,700	9,800	173	499.22	86
7	1,700	9,800	173	499.22	86
8	1,700	9,800	173	499.22	86
9	1,700	9,800	173	499.22	86
10	1,700	9,800	173	499.22	86
11	1,500	9,800	153	499.22	76
12	1,500	9,800	153	499.22	76
13	1,500	9,800	153	499.22	76
14	1,500	9,800	153	499.22	76
15	1,500	9,800	153	499.22	76
16	1,000	9,800	102	499.22	51
17	1,000	9,800	102	499.22	51
18	1,000	9,800	102	499.22	51
19	1,000	9,800	102	499.22	51
20	1,000	9,800	102	499.22	51
21	1,000	9,800	102	499.22	51
22	1,000	9,800	102	499.22	51
23	1,000	9,800	102	499.22	51
24	1,000	9,800	102	499.22	51
25	1,000	9,800	102	499.22	51
26	800	9,800	82	499.22	41
27	800	9,800	82	499.22	41
28	800	9,800	82	499.22	41
29	800	9,800	82	499.22	41
30	800	9,800	82	499.22	41
31	800	9,800	82	499.22	41
32	800	9,800	82	499.22	41
33	800	9,800	82	499.22	41
34	800	9,800	82	499.22	41
35	800	9,800	82	499.22	41
Total	39,500		4,031		2,008

200 - BLASTING

Sheet 2 of 10

Account item: 200 and 230 Blasting Waste Material

	(1)	(2)	(3)	(4)	(5)
<u>Task</u>		<u>Productivity</u>			
Bank m <sup>3</sup> Mat. to be Blasted (fr. Prod. Year Sched.) (x10 <sup>3</sup> )	Bank m <sup>3</sup> Mat. Blasted Per Shift (fr. Prod. Stds.)	No. of Shifts Required (1) ÷ (2)	\$ Cost/Shift (fr. Cost Std.)	\$ Total Annual Cost (x10 <sup>3</sup> ) (3) x (4)	
-2					
-1	400	9,800	41	1,430	59
1	400	9,800	41	1,430	59
2	700	9,800	71	1,430	102
3	1,000	9,800	102	1,430	146
4	1,500	9,800	153	1,430	219
5	1,500	9,800	153	1,430	219
6	1,700	9,800	173	1,430	247
7	1,700	9,800	173	1,430	247
8	1,700	9,800	173	1,430	247
9	1,700	9,800	173	1,430	247
10	1,700	9,800	173	1,430	247
11	1,500	9,800	153	1,430	219
12	1,500	9,800	153	1,430	219
13	1,500	9,800	153	1,430	219
14	1,500	9,800	153	1,430	219
15	1,500	9,800	153	1,430	219
16	1,000	9,800	102	1,430	146
17	1,000	9,800	102	1,430	146
18	1,000	9,800	102	1,430	146
19	1,000	9,800	102	1,430	146
20	1,000	9,800	102	1,430	146
21	1,000	9,800	102	1,430	146
22	1,000	9,800	102	1,430	146
23	1,000	9,800	102	1,430	146
24	1,000	9,800	102	1,430	146
25	1,000	9,800	102	1,430	146
26	800	9,800	82	1,430	117
27	800	9,800	82	1,430	117
28	800	9,800	82	1,430	117
29	800	9,800	82	1,430	117
30	800	9,800	82	1,430	117
31	800	9,800	82	1,430	117
32	800	9,800	82	1,430	117
33	800	9,800	82	1,430	117
34	800	9,800	82	1,430	117
35	800	9,800	82	1,430	117
Total	39,500		4,031		5,764

## 300 - LOADING

Sheet 3 of 10

Account item: 310 Loading Coal

	(1)	(2)	(3)	(4)	(5)
Task	Productivity				
Bank m <sup>3</sup> Mat. to be Loaded (fr. Prod. Year Sched.) (x10 <sup>3</sup> )	Bank m <sup>3</sup> Mat. Loaded Per Shift (fr. Prod. Stds.)	No. of Shifts Required (1) ÷ (2)	\$ Cost/Shift (fr. Cost Std.)	\$ Total Annual Cost (x10 <sup>3</sup> ) (3) x (4)	
-2					
-1	764	4,558	168	639.99	107
1	1,980	4,558	434	639.99	278
2	3,194	4,558	701	639.99	448
3	4,947	4,558	1,085	639.99	694
4	6,207	4,558	1,362	639.99	872
5	7,170	4,558	1,573	639.99	1,007
6	7,015	4,558	1,539	639.99	985
7	7,019	4,558	1,540	639.99	986
8	7,755	4,558	1,701	639.99	1,089
9	7,277	4,558	1,596	639.99	1,022
10	7,498	4,558	1,645	639.99	1,053
11	7,742	4,558	1,699	639.99	1,087
12	7,115	4,558	1,561	639.99	999
13	7,730	4,558	1,696	639.99	1,085
14	7,642	4,558	1,677	639.99	1,073
15	7,437	4,558	1,632	639.99	1,044
16	6,743	4,558	1,479	639.99	947
17	6,856	4,558	1,504	639.99	962
18	7,085	4,558	1,554	639.99	995
19	6,854	4,558	1,504	639.99	962
20	6,685	4,558	1,467	639.99	939
21	6,586	4,558	1,445	639.99	925
22	6,605	4,558	1,449	639.99	927
23	6,654	4,558	1,460	639.99	934
24	6,635	4,558	1,456	639.99	932
25	6,757	4,558	1,482	639.99	949
26	5,560	4,558	1,220	639.99	781
27	5,690	4,558	1,248	639.99	799
28	5,634	4,558	1,236	639.99	791
29	5,746	4,558	1,261	639.99	807
30	5,761	4,558	1,264	639.99	809
31	5,807	4,558	1,274	639.99	815
32	5,710	4,558	1,253	639.99	802
33	5,535	4,558	1,214	639.99	777
34	5,405	4,558	1,186	639.99	759
35	5,115	4,558	1,122	639.99	718
Total	221,915 (330,950 t)		48,687		31,159

## 300 - LOADING

Sheet 4 of 10

Account item: 320 and 330 Loading All Waste Materials (except waste partings)

	(1)	(2)	(3)	(4)	(5)
Task	Productivity				
Bank m <sup>3</sup> Mat. to be Loaded (fr. Prod. Year Sched.) (x10 <sup>3</sup> )	Bank m <sup>3</sup> Mat. Loaded Per Shift (fr. Prod. Stds.)	No. of Shifts Required (1) ÷ (2)	\$ Cost/Shift (fr. Cost Std.)	\$ Total Annual Cost (x10 <sup>3</sup> ) (3) x (4)	
-2	1,800	5,998	300	913.13	274
-1	2,700	5,998	450	913.13	411
1	4,080	5,998	680	913.13	621
2	6,998	5,998	1,167	913.13	1,065
3	9,983	5,998	1,664	913.13	1,520
4	14,695	5,998	2,450	913.13	2,237
5	15,505	5,998	2,585	913.13	2,360
6	15,775	5,998	2,630	913.13	2,402
7	15,895	5,998	2,650	913.13	2,420
8	15,984	5,998	2,665	913.13	2,433
9	16,914	5,998	2,820	913.13	2,575
10	16,914	5,998	2,820	913.13	2,575
11	17,094	5,998	2,850	913.13	2,602
12	16,555	5,998	2,760	913.13	2,520
13	16,255	5,998	2,710	913.13	2,475
14	14,995	5,998	2,500	913.13	2,283
15	13,795	5,998	2,300	913.13	2,100
16	13,196	5,998	2,200	913.13	2,009
17	11,996	5,998	2,000	913.13	1,826
18	10,796	5,998	1,800	913.13	1,644
19	9,777	5,998	1,630	913.13	1,488
20	9,597	5,998	1,600	913.13	1,461
21	9,277	5,998	1,547	913.13	1,412
22	9,277	5,998	1,547	913.13	1,412
23	8,997	5,998	1,500	913.13	1,370
24	8,997	5,998	1,500	913.13	1,370
25	8,997	5,998	1,500	913.13	1,370
26	8,997	5,998	1,500	913.13	1,370
27	8,997	5,998	1,500	913.13	1,370
28	8,997	5,998	1,500	913.13	1,370
29	9,853	5,998	1,643	913.13	1,500
30	9,855	5,998	1,643	913.13	1,500
31	9,863	5,998	1,644	913.13	1,502
32	9,848	5,998	1,642	913.13	1,499
33	9,822	5,998	1,637	913.13	1,495
34	2,350	5,998	392	913.13	358
35	1,960	5,998	327	913.13	299
Total	397,386		66,253		60,498

## 300 - LOADING

Sheet 5 of 10

Account item: 320 Loading Consolidated Waste Partings

	(1)	(2)	(3)	(4)	(5)
Task	Productivity				
Bank m <sup>3</sup> Mat. to be Loaded (fr. Prod. Year Sched.) (x10 <sup>3</sup> )	Bank m <sup>3</sup> Mat. Loaded Per Shift (fr. Prod. Stds.)	No. of Shifts Required (1) ÷ (2)	\$ Cost/Shift (fr. Cost Std.)	\$ Total Annual Cost (x10 <sup>3</sup> ) (3) x (4)	
-2					
-1	114	3,483	33	639.99	21
1	295	3,483	85	639.99	54
2	476	3,483	137	639.99	88
3	737	3,483	212	639.99	135
4	925	3,483	266	639.99	170
5	1,068	3,483	307	639.99	196
6	1,045	3,483	300	639.99	192
7	1,046	3,483	300	639.99	192
8	1,156	3,483	332	639.99	212
9	1,084	3,483	311	639.99	199
10	1,117	3,483	321	639.99	205
11	1,154	3,483	331	639.99	212
12	1,060	3,483	304	639.99	195
13	1,152	3,483	331	639.99	212
14	1,139	3,483	327	639.99	209
15	1,108	3,483	318	639.99	204
16	1,005	3,483	288	639.99	185
17	1,022	3,483	293	639.99	188
18	1,056	3,483	303	639.99	194
19	1,021	3,483	293	639.99	188
20	996	3,483	286	639.99	183
21	982	3,483	282	639.99	181
22	984	3,483	283	639.99	181
23	992	3,483	285	639.99	182
24	1,018	3,483	292	639.99	187
25	1,007	3,483	289	639.99	185
26	829	3,483	238	639.99	152
27	848	3,483	243	639.99	156
28	840	3,483	241	639.99	154
29	856	3,483	246	639.99	157
30	858	3,483	246	639.99	158
31	866	3,483	249	639.99	159
32	851	3,483	244	639.99	156
33	825	3,483	237	639.99	152
34	806	3,483	231	639.99	148
35	762	3,483	219	639.99	140
Total	33,100		9,503		6,082

## 400 - HAULING

Sheet 6 of 10

Account item: 410 Hauling Coal

	(1)	(2)	(3)	(4)	(5)
Year	<u>Task</u> Bank m <sup>3</sup> Mat. to be Hauled (fr. Prod. Year Sched.) (x10 <sup>3</sup> )	<u>Productivity</u> Bank m <sup>3</sup> Mat. Hauled Per Shift (fr. Prod. Stds.)	No. of Shifts Required (1) ÷ (2)	\$ Cost/Shift (fr. Cost Std.)	\$ Total Annual Cost (x10 <sup>3</sup> ) (3) x (4)
-2					
-1	764	1,260	606	491.28	298
1	1,980	1,537	1,288	491.28	633
2	3,194	1,462	2,185	491.28	1,073
3	4,947	1,416	3,494	491.28	1,717
4	6,207	1,371	4,527	491.28	2,224
5	7,170	1,255	5,713	491.28	2,807
6	7,015	1,169	6,001	491.28	2,948
7	7,019	1,220	5,753	491.28	2,826
8	7,755	1,411	5,496	491.28	2,700
9	7,277	1,457	4,995	491.28	2,454
10	7,498	1,356	5,529	491.28	2,716
11	7,742	1,265	6,120	491.28	3,007
12	7,115	1,250	5,692	491.28	2,796
13	7,730	1,230	6,285	491.28	3,088
14	7,642	1,194	6,400	491.28	3,144
15	7,437	1,169	6,362	491.28	3,125
16	6,743	1,124	5,999	491.28	2,947
17	6,856	1,104	6,210	491.28	3,051
18	7,085	1,119	6,332	491.28	3,111
19	6,854	1,169	5,863	491.28	2,880
20	6,685	1,230	5,435	491.28	2,670
21	6,586	1,497	4,399	491.28	2,161
22	6,605	1,351	4,889	491.28	2,402
23	6,654	1,426	4,666	491.28	2,292
24	6,635	1,411	4,702	491.28	2,310
25	6,757	1,512	4,469	491.28	2,196
26	5,560	1,562	3,560	491.28	1,749
27	5,690	1,562	3,643	491.28	1,790
28	5,634	1,361	4,140	491.28	2,034
29	5,746	1,361	4,222	491.28	2,074
30	5,761	1,512	3,810	491.28	1,872
31	5,870	1,562	3,718	491.28	1,827
32	5,710	1,562	3,656	491.28	1,796
33	5,535	1,512	3,661	491.28	1,799
34	5,405	1,512	3,575	491.28	1,756
35	5,115	1,512	3,383	491.28	1,662
Total	221,915 (330,950 t)		166,778		81,935



## 400 - HAULING

Sheet 7 of 10

Account item: 420 Hauling Consolidated Waste Partings

	(1)	(2)	(3)	(4)	(5)
Task	Productivity		No. of Shifts Required (1) ÷ (2)	\$ Cost/Shift (fr. Cost Std.)	\$ Total Annual Cost (x10 <sup>3</sup> ) (3) x (4)
Bank m <sup>3</sup> Mat. to be Hauled (fr. Prod. Year Sched.) (x10 <sup>3</sup> )	Bank m <sup>3</sup> Mat. Hauled Per Shift (fr. Prod. Stds.)	Bank m <sup>3</sup> Mat. Hauled Per Shift (fr. Prod. Stds.)			
-2					
-1	400	963	118	491.28	58
1	295	1,174	251	491.28	123
2	476	1,117	426	491.28	209
3	737	1,082	681	491.28	335
4	925	1,047	883	491.28	434
5	1,068	959	1,114	491.28	547
6	1,045	893	1,170	491.28	575
7	1,046	932	1,122	491.28	551
8	1,156	1,078	1,078	491.28	527
9	1,084	1,113	974	491.28	478
10	1,117	1,036	1,078	491.28	530
11	1,154	966	1,195	491.28	587
12	1,060	955	1,110	491.28	545
13	1,152	939	1,227	491.28	603
14	1,139	912	1,249	491.28	614
15	1,108	893	1,241	491.28	610
16	1,005	859	1,170	491.28	575
17	1,022	843	1,212	491.28	595
18	1,056	855	1,235	491.28	607
19	1,021	893	1,143	491.28	562
20	996	939	1,061	491.28	521
21	982	1,143	859	491.28	422
22	984	1,032	953	491.28	468
23	992	1,090	910	491.28	447
24	1,018	1,078	944	491.28	464
25	1,007	1,155	872	491.28	428
26	829	1,194	694	491.28	341
27	848	1,194	710	491.28	397
29	856	1,040	823	491.28	404
30	858	1,155	743	491.28	365
31	866	1,194	725	491.28	356
32	851	1,194	713	491.28	350
33	825	1,155	714	491.28	351
34	806	1,155	698	491.28	343
35	762	1,155	660	491.28	324
Total	33,100		32,558		15,995

## 400 - HAULING

Sheet 8 of 10

Account item: 420 and 430 Hauling All Waste Materials (except waste partings)

	(1)	(2)	(3)	(4)	(5)
Year	<u>Task</u> Bank m <sup>3</sup> Mat. to be Hauled (fr. Prod. Year Sched.) (x10 <sup>3</sup> )	<u>Productivity</u> Bank m <sup>3</sup> Mat. Hauled Per Shift (fr. Prod. Stds.)	No. of Shifts Required (1) ÷ (2)	\$ Cost/Shift (fr. Cost Std.)	\$ Total Annual Cost (x10 <sup>3</sup> ) (3) x (4)
-2	1,800	1,820	989	696.56	689
-1	2,700	1,820	1,484	696.56	1,034
1	4,080	2,038	2,002	696.56	1,394
2	6,998	1,966	3,560	696.56	2,480
3	9,983	1,856	5,379	696.56	3,747
4	14,695	1,784	8,237	696.56	5,738
5	15,505	1,747	8,875	696.56	6,182
6	15,775	1,682	9,379	696.56	6,533
7	15,895	1,638	9,704	696.56	6,759
8	15,984	1,733	9,223	696.56	6,424
9	16,914	1,762	9,599	696.56	6,686
10	16,914	1,747	9,682	696.56	6,744
11	17,094	1,784	9,582	696.56	6,674
12	16,555	1,638	10,107	696.56	7,040
13	16,255	1,602	10,147	696.56	7,068
14	14,995	1,602	9,360	696.56	6,520
15	13,795	1,602	8,611	696.56	5,998
16	13,196	1,602	8,237	696.56	5,738
17	11,996	1,602	7,488	696.56	5,216
18	10,796	1,602	6,739	696.56	4,694
19	9,777	1,674	5,841	696.56	4,069
20	9,597	1,602	5,991	696.56	4,173
21	9,277	1,616	5,741	696.56	3,999
22	9,277	1,572	5,901	696.56	4,110
23	8,997	1,784	5,043	696.56	3,513
24	8,997	1,674	5,375	696.56	3,744
25	8,997	1,674	5,375	696.56	3,744
26	8,997	1,638	5,493	696.56	3,826
27	8,997	1,602	5,616	696.56	3,912
28	8,997	1,602	5,612	696.56	3,912
29	9,853	1,602	6,150	696.56	4,284
30	9,855	1,674	5,887	696.56	4,100
31	9,863	1,784	5,529	696.56	3,851
32	9,848	1,769	5,567	696.56	3,878
33	9,822	1,747	5,622	696.56	3,916
34	2,350	1,747	1,345	696.56	937
35	1,960	1,674	1,171	696.56	816
Total	397,386		235,647		164,142

Account item: 621, 622, and 623 Conveying Waste (Year 8)Operating Labour

Operator	No. Per Shift	Shifts/Day		Total	Yearly Wages Per Operator	Total Annual Labour Cost
		Days/Week				
*(a) control room	1	<del>3</del> 7		4	\$30,532	\$81,420
*(b) primary crusher	2	<del>3</del> 7		8	\$28,280	\$141,400
*(c) conveyor patrol (in-pit)	1	<del>3</del> 7		4	\$27,540	\$72,454
(d) conveyor patrol (overland and dumps)	3	<del>3</del> 7		12	\$27,540	\$330,480
(e) spreader	2	<del>3</del> 7		8	\$31,275	\$250,220
(f) day crew (conv. shifting, etc.)	4	<del>1</del> 5		4	\$25,290	\$101,160
(g) labourer (clean-up)	2	<del>1</del> 5		2	\$25,290	\$50,580
				42		\$1,028,000

\* These operators split 2/3 to waste, 1/3 to coal.

...continued...

Maintenance Costs

Includes maintenance (labour, parts, supplies, and overhead - operating supplies also included). These costs are calculated as a percentage of capital costs.

Year 8:

Equipment	\$ x 10 <sup>3</sup> Capital Cost	% of Capital Cost	\$ x 10 <sup>3</sup> Maintenance Cost
<u>In-pit</u>			
Waste Crusher Station	2,019	5	101.0
Waste/Clay Crusher Station	2,842	5	142.1
Waste conveyors	1,848	5	92.5
Waste/clay conveyors	1,848	5	92.5
Surface Plant	780	5	39.0
<u>Waste Dumps</u>			
Overland conveyors	3,951	5	197.6
Transfer conveyors	4,195	5	209.8
Shiftable conveyors	5,086	6	304.2
Portable conveyors	160	5	8.0
Belt trippers	1,284	4	51.4
Spreaders	8,030	3	240.9
			<u>1,480.0</u>

Maintenance Labour

Determined as 50% of total maintenance costs.

\$ x 10 <sup>3</sup> Maintenance Costs	Maintenance Labour \$ x 10 <sup>3</sup>	Average Yearly Wages Per Mechanic	No. of Mechanics
1,480	740	32,039	23



14.5                    FINANCIAL ANALYSIS

14.5.1                Approach

Before carrying out the financial analysis all costs associated with the mining of Hat Creek coal were compiled. In addition to the costs described in the previous sections, costs were allocated to the mining project for the off-site facilities (Hat Creek Diversion, construction camp, and discretionary expenses), land, and ongoing studies associated with the project. These costs are shown in Table 14-12.

The objective of this analysis is to determine the price in 1979 dollars of Hat Creek coal delivered to the powerplant. At this price the mining venture must yield a rate of return equal to B.C. Hydro's cost of capital. The price of Hat Creek coal delivered to the powerplant could then be compared with any alternative fuel with an equivalent energy content.

14.5.2                Parameters

The financial parameters used in this analysis are as follows:

- (1) The base date for economic calculations is October 1979 and the capital and operating cash flows are in 1979 dollars;
- (2) Inflation rates

The following inflation rates were applied to the cash flows:

<u>Fiscal Year</u>	<u>Rate %</u>
1979-1980	8.50
1980-1981	7.75
1981-1982	7.50
1982-1983	7.25

<u>Fiscal Year</u>	<u>Rate %</u>
1983-1984	7.00
after 1984-1985	6.00

(3) Plant operating date

It is assumed that the first unit commences operation in the fiscal year 1989-1990;

(4) Debt:Equity ratio

The financial structure is 100% debt;

(5) Rate of return

A rate of return of 9% is required to cover interest only. No operating profit assumed;

(6) Income tax

No income tax is paid by B.C. Hydro;

(7) Provincial royalty

In the financial analysis, the royalties were calculated as 3.5% of the total capital and operating costs for the project;

(8) Corporate overhead

Corporate overhead has been calculated at 9% of the total capital cost incurred;

(9) Construction Insurance and Bonds

Construction insurance and bonds were calculated at 0.5% of the total capital costs plus 0.044% of the total operating costs. These costs were added to the total costs of the project.

14.5.3 Analysis

The present values of the cash outflows and inflows associated with the project were equated. The cash outflows are the

annual capital and operating cash requirements associated with the mining operations and the cash inflows are determined from the schedule of coal to be supplied to the powerplant and the price of the delivered coal.

This analysis incorporated the inflation rates stipulated above, a discount rate of 9% and a time horizon of 54 years since expenditures are incurred nine years prior to the start of production, and reclamation activities continue for a 10-year period after mining ceases.

#### 14.5.4            Conclusion

Based on the above financial parameters, the price of Hat Creek coal delivered to the powerplant is \$0.60/GJ in 1979 dollars, which is equivalent to \$8.27 per tonne of coal with an average heating value of 18 MJ/kg, dry basis. If the cost of power for the mining operations is excluded the price of coal is reduced to \$0.57/GJ (\$7.80 per tonne of coal).



TABLE 14-12

OTHER COSTS ALLOCATED TO MINING PROJECT

Fiscal Year 1989 in Service	-9 80/81	-8 81/82	-7 82/83	-6 83/84	-5 84/85	-4 85/86	-3 86/87	-2 87/88	-1 88/89	1 89/90	2 90/91	3 91/92	Totals
Ongoing Studies	555	490	445	330	330	180	205	205	205	50	2	2	2,999
Off-site Facilities:													
Creek Diversion				380	540	5,680	8,070						14,670
Construction Camp			10	72	2,056	918	375	1,652	812	35	10		5,940
Discretionary Expenses		666	1,334	1,867	5,392	4,525	1,067	333	333	333	300		16,150
Total Off-site Facilities	0	666	1,344	2,319	7,988	11,123	9,512	1,985	1,145	368	310	0	36,760
Land	910	410	70	70	70	70	70	70	70				1,810
Grand Totals	1,465	1,566	1,859	2,719	8,388	11,373	9,787	2,260	1,420	418	312	2	41,569

14 - 63

Canadian \$000's October 1979

SECTION 15

MINING REPORTS AND STUDIES

- 1 Duffell, S. and K.C. McTaggart, *Ashcroft Map - Area, B.C.*, Memoir 262, p. 122, Geological Survey of Canada (including Map No. 1010A), 1951.
- 2 McCullough, P.T., *Hat Creek Magnetometer Survey*, B.C. Hydro File, 1975.
- 3 Rouse, G.E., *Palynological Zonation and Correlation of Hat Creek Core Samples*, 1976.
- 4 PD-NCB/Wright/Golder, *Preliminary Report on Hat Creek Openpit No. 1*, Volumes 1 and 2, March 1976 (Report No. 2).
- 5 PD-NCB/Wright/Golder, *Preliminary Report on Hat Creek Openpit No. 2*, Volumes 1 and 2, March 1976 (Report No. 3).
- 6 Birtley, *Results of Washability and Plant Washing of Samples from A, B and C - the Hat Creek Deposit*, June 1976.
- 7 BCH Thermal Division, *Final Report - Bulk Sample Program - Hat Creek No. 1 Deposit*, 1977.
- 8 Church, B.N., "Geology of the Hat Creek Basin", in *Geology in British Columbia*, B.C. Ministry of Mines Publication, 1977.
- 9 Dr. A.J. Sinclair, *Evaluation of Analytical Data from Test Holes 76-135 and 76-136 - Hat Creek No. 1 Coal Deposit*, March 1977.
- 10 PD-NCB/Wright/Golder, *Revised Report on Hat Creek Openpit No. 1*, Volumes 1 and 2, March 1977 (Report No. 9).
- 11 PD-NCB/Wright/Golder, *Hat Creek Geotechnical Study*, Volumes 1-4, March 1977 (Report No. 6).

- 12 Acoustical Engineering, *Noise Levels Generated by the Hat Creek Bulk Sample Program, Trench A*, June 8, 1977.
- 13 Dolmage Campbell, *Exploration Report - No. 1 Hat Creek Coal Development*, Volumes 1 and 2, June 15, 1977.
- 14 UBC Department of Metallurgy, *Mineral Matter Content and Gross Properties of Hat Creek Coal*, July 1977.
- 15 Stone and Webster, *Hat Creek Coal Utilization Study*, October 1977.
- 16 BCH Hydro-electric Design Division, Report No. 913, *Diversion of Hat and Finney Creeks*, Preliminary Design Report, March 1978.
- 17 B.C. Hydro/Canmet, *Pilot-scale Preparation Studies with Hat Creek Coal*, April 1978.
- 18 EMR, *A Pilot-scale Feasibility Study on Water-only Washing of Hat Creek Coal*, April 1978, final report February 1979.
- 19 Mintec, Inc., *Minability Study - Hat Creek Project*, April 1978.
- 20 IREM-MERI, *Preliminary Geostatistical Survey of Btu Variations in the Hat Creek Deposit*, May 1978.
- 21 Dagbert, Francois; Bongarcon, David, *Preliminary Geostatistical Study of Btu Variations in the Hat Creek Deposit*, May 16, 1978.
- 22 IREM-MERI, *Geostatistical Study of Sulphur Variation in the Hat Creek Deposit*, June 1978.
- 23 CMJV, *Hat Creek Project, Mining Feasibility Report, Vol. I, "Summary"*, July 1978.
- 24 CMJV, *Hat Creek Project, Mining Feasibility Report, Vol. II, "Geology and Coal Quality"*, July 1978.
- 25 CMJV, *Hat Creek Project, Mining Feasibility Report, Vol. III, "Mine Planning"*, July 1978.
- 26 CMJV, *Hat Creek Project, Mining Feasibility Report, Vol. IV, "Mine Support Facilities"*, July 1978.

- 27 CMJV, *Hat Creek Project, Mining Feasibility Report, Vol. V, "Mine Reclamation and Environmental Protection"*, July 1978.
- 28 CMJV, *Hat Creek Project, Mining Feasibility Report, Vol. VI, "Capital and Operating Costs"*, July 1978.
- 29 CMJV, *Hat Creek Project, Mining Feasibility Report, Appendix A, "Study on the Application of Bucket Wheel Excavators for the Exploitation of the Hat Creek Deposit (NAMCO-Rheinbraun)"*, July 1978.
- 30 CMJV, *Hat Creek Project, Mining Feasibility Report, Appendix B, "Hat Creek Coal Beneficiation" {Simon-Carves (Canada) Ltd.}*, July 1978.
- 31 BCH Thermal Division, *Final Report - Bulk Sample Program*, August 1978.
- 32 Simon-Carves, *Hat Creek Coal Beneficiation - Interim Reports, Volumes 1-5*, October 1978.
- 33 Golder Associates, *Hat Creek Project Preliminary Engineering Work, Geotechnical Technical Study 1977-1978, Volumes 1-6*, final report December 1978.
- 34 BCH Thermal Division, *1978 Environmental Field Program Report*, April 1979.
- 35 Belisle, J.M./IREM-MERI, *Progress Report No. 2 on the Hat Creek Deposit Geostatistical Estimation*, (two volumes), July 1979.
- 36 IREM-MERI, *Geostatistical Estimation of the Hat Creek Deposit - Final Report*, July 1979.
- 37 Simon-Carves, *Materials handling, screening, crushing and low grade coal beneficiation (Hat Creek)*, August 1979.
- 38 BCH Hydro Electric Generation Project Division, *memorandum on Proposed Waste Disposal Embankment Studies, Report No. H1129*, October 1979.
- 39 Paul Weir Company, *Review of Coal Fuel Specification Hat Creek Project*, November 1979.

- 40 BCH, *Geostatistical Study of Sulphur Variations in the Hat Creek Deposit*, 1979.
- 41 CMJV, *Mine Drainage*, 1979.
- 42 CMJV, *Fugitive Mine-dust Study*, 1979.
- 43 BCH, *Depositional Environment and Stratigraphic Subdivision, Hat Creek No. 1 Deposit*, October 1979.